



Making British gardens great

Thank you for purchasing your shed from Forest Garden. No matter what size garden, a shed is the most practical of garden structures. Simply follow these step by step instructions and our top tips and you'll be enjoying your shed for many years to come. If you have any questions or need advice, our friendly team is here to help.

SHED INSTRUCTIONS

WORKSHOP COMBO DOUBLE DOOR (8x12)

FIXING PACK CONTAINS:

FIXING PACK CODE: TPAC812DDMFP

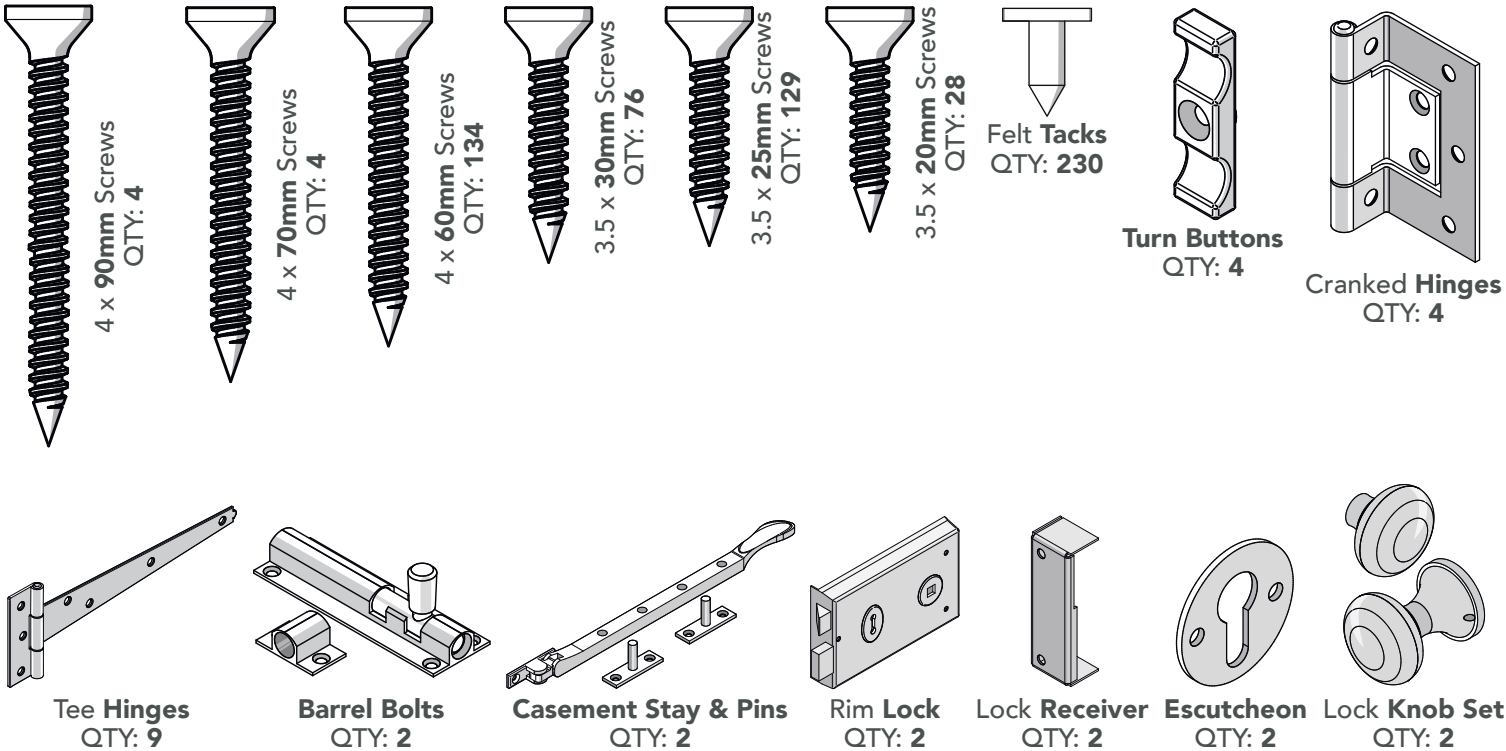

Missing something or need more information?
Call our aftersales team on
0333 321 3142

Visit our website for spare instructions and
more information
www.forestgarden.co.uk

BEFORE YOU START

Please read through these instructions to familiarise yourself with your shed. We recommend that you **check all the components** using the lists found on the front and back pages before you start to build.

All of our sheds are constructed in the same way. They simply come with different components depending on the type of shed you have. Don't worry if your fixing pack contains some spare items at the end of the build (you haven't missed a bit!) we have sent you a generic fixing pack to suit the shed range.

Please take care when unpacking, handling and assembling the toughened safety glass windows. We recommend wearing cut-resistant gloves in the event of a breakage, as it will disintegrate into small pieces.

BASE PREPARATION

It's vital that you build your new shed on a **solid, level base**. Timber or Plastic Shed Bases are ideal, as is solid concrete or concrete slabs.

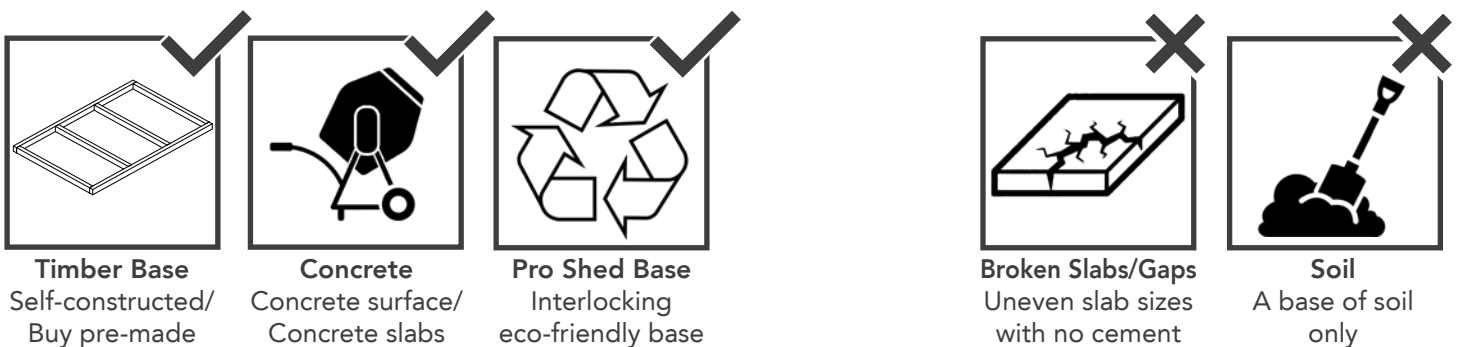

If you have an existing base and think it's suitable for your new shed to be sited on, it is important you check that it is level and doesn't deviate by any more than 15mm from edge to edge. If this isn't the case the building will twist, causing gaps to appear in the sections and the roof, doors and windows to misalign.

There's more information on base preparation on our website www.forestgarden.co.uk

TOOLS NEEDED

We recommend using the following tools (not supplied):

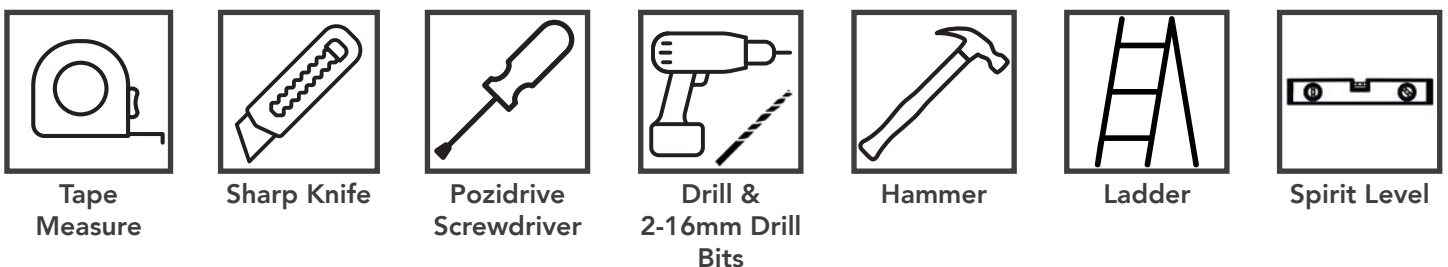

Assembly is relatively straightforward if you follow these step by step instructions. We recommend getting everything aligned properly before screwing together and that **screw holes should be pre-drilled** to avoid splitting the timber.



IMPORTANT
Assembly requires 2+ adults.



REMINDER
Always pre-drill before screwing.

PLEASE KEEP PLASTIC BAGS AND SMALL PARTS AWAY FROM CHILDREN

To help you get the most out of our products it's useful to know a little more about the properties of timber, what's normal and how your shed may behave as the seasons change. Wood is an extremely durable material for construction but as a natural product when used outdoors it is susceptible to changes in the environment.

THINGS THAT YOU MIGHT SEE IN YOUR PRODUCT



MOVEMENT, TWISTING & WARPING

Wood contains a natural level of moisture so decreasing humidity levels in the surrounding air may cause panels to change their shape as the porous fibres shrink. This can be exaggerated during prolonged periods of dry weather. Movement and gaps in timber products are normal, in most cases the wood will revert to its original form once the high temperatures subside and there is more moisture content in the air. Similarly, in the winter months, the opposite may occur with wood swelling.

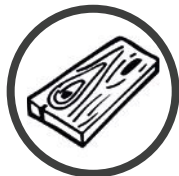

EXPANSION, CONTRACTION, SPLITS & CRACKS

All timber will expand and contract according to its environment. As a result of this expansion and contraction, it is very common to see splits and cracks developing in the wood. Splits are common during the spring and summer months as the wood begins to dry out. The outer surface dries first and contracts, contracting over a still expanded core of the wood. The result of this is that splits and cracks appear along the grain of wood. These splits are not a fault and do not affect the structural integrity of a product.



MOULD & BLUE STAIN

Mould is a surface-dwelling fungus that feeds on the nutrients and debris contained in the surface cells of timber. The most common problems associated with mould are discoloured timber and an increase in permeability of the timber. Blue stain is part of the same family but penetrates deeper into the surface layers of the timber. It stains the timber a dark blue, whereas mould is usually black. These do not cause the timber to rot. Keep the building well ventilated to avoid mould.

Treat your building annually, we advise the application of a high quality preservative that contains a mildewcide. For more information on the conditions of our guarantee see forestgarden.co.uk.

ADVICE ON FELT HANDLING & USAGE

Roofing felt is flexible at temperatures above 5°C. In cold temperatures extra care must be taken when handling and installing to prevent cracking and damage to the felt. The felt should not be rolled, folded or used in temperatures lower than 5° C. In cold temperatures the felt should be stored above 10°C (indoors) for 24 hours prior to use. Felt must be lifted, not dragged and should be stored on its end on a dry surface.

THE ROOF OF THIS BUILDING IS NOT A LOAD BEARING STRUCTURE

8 TOP TIPS TO ENSURE YOUR SHED IS FULLY WATERPROOF

- 1 MAKE SURE YOU POSITION YOUR SHED IN THE BEST LOCATION IN YOUR GARDEN**
Avoid areas where water pools and is constantly wet. Position away from trees and cut back any overhanging foliage which can cause moisture to be trapped against shed walls and debris to collect on the roof.
- 2 RAISE YOUR SHED OFF THE GROUND**
Ideally any concrete base should be the same footprint as the shed to allow surface water to run off without pooling, a timber shed base can also be used. Raise 50mm above ground level.
- 3 SEAL THE BASE**
We recommend a treatment containing wax or oil, paint the bearers that come into contact with the ground to prevent moisture coming up.
- 4 USE AN END-GRAIN PROTECTOR**
To protect the corners and panel joints, an end grain treatment can be applied.
- 5 SEAL THE PANELS & WINDOWS**
Use a flexible silicone sealant around windows to prevent water ingress. This can also be used where 2 sections of the shed joint together. Apply internally.
- 6 CONSIDER ADDING GUTTERS**
Adding guttering around the fascia of the shed will redirect rain water away from the shed's foundation.
- 7 KEEP VENTILATED**
Good airflow around the perimeter of the shed and regular ventilation inside the shed will help prevent mould and mildew.
- 8 CONSIDER A WEATHERPROOFING STAIN OR CLEAR TREATMENT**
We recommend you paint your garden shed with a weatherproofing treatment at least once a year. This will help maintain the wood, stabilise timber movement and help prolong the life of your shed.

HEALTH & SAFETY

We strongly recommend that PPE (Personal Protective Equipment) is used throughout your build to ensure you are protected from any potential health and safety risks. **Do not exempt yourself from wearing PPE.**



IDENTIFY YOUR SHED

Use the **floor plan** below, to identify the side panel positions before assembling your shed.
Use the key and visuals below as a guide.

KEY

A Plain Panel
(328 x 1831mm)

B Plain Panel
(577 x 1831mm)

C Plain Panel
(1147 x 1831mm)

D Plain & Window Panel (1180 x 1831mm)
(These panels are interchangeable)

E Single Door Panel
(1180 x 1831mm)

F Internal Plain Panel
(1147 x 1798mm)

G Double Door Panel
(1704 x 1831mm)



Indicates the panel orientation during construction.
This will apply to all of the corners for your chosen shed.

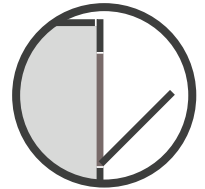

The single door is flexible for all shed types and can be hinged onto either side.

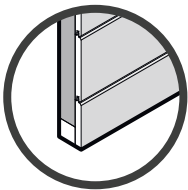

Please Note
The Internal Panels will have the bottom board flush to the framework.

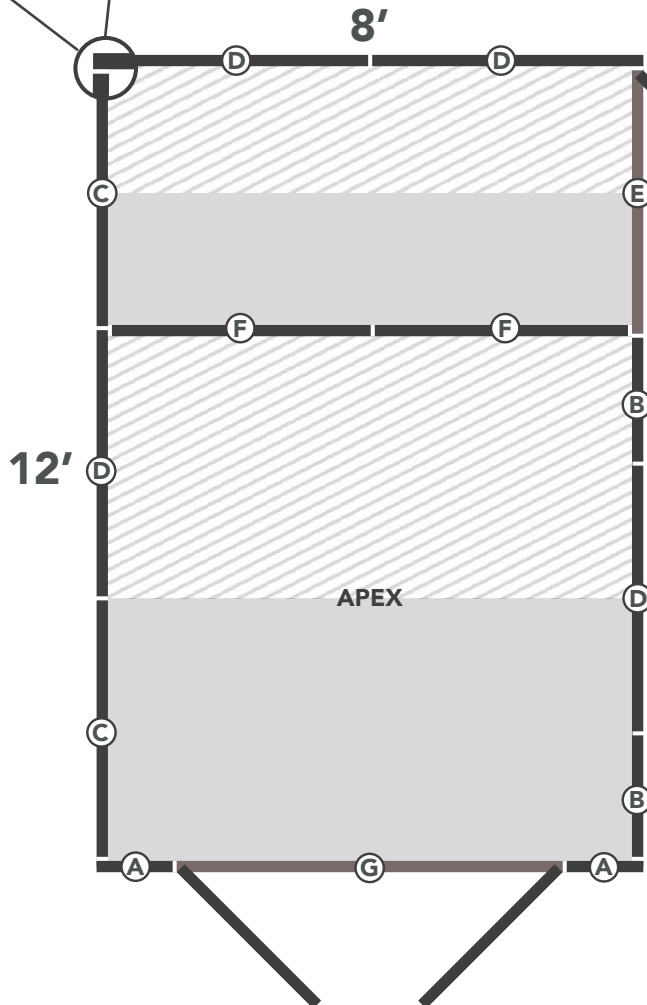

PANEL POSITION

When assembling your wall panels, ensure the **timber framing** on the panels are **flush** at the corners. The space left next to the board is for the cover strip to sit into. Ensure to apply the same panel position to all corners.

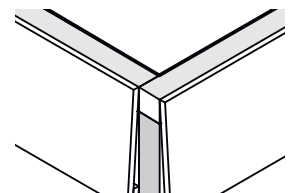

1a FLOOR & PANEL LAYOUT



Position and butt the floors together in your desired location.

Layout the panels around your shed base.

We recommend to start in a back corner then work from the back panels to the front panels for assembly.

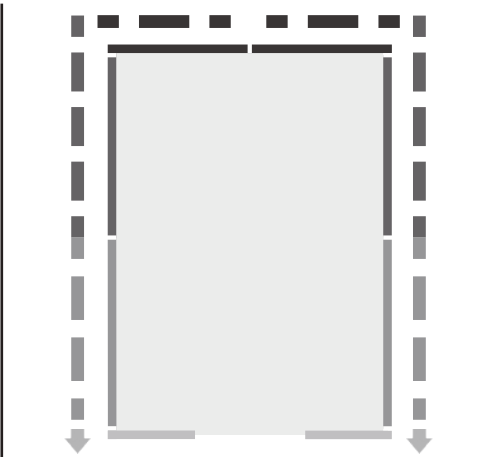
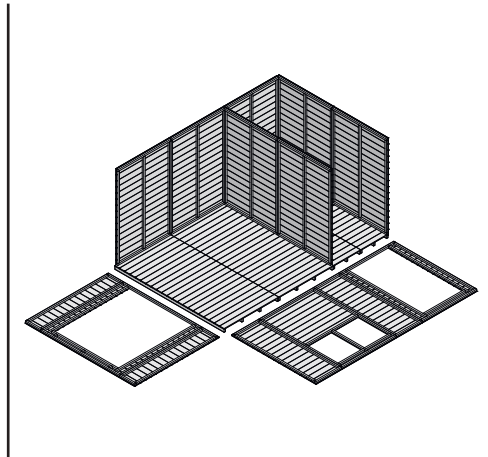
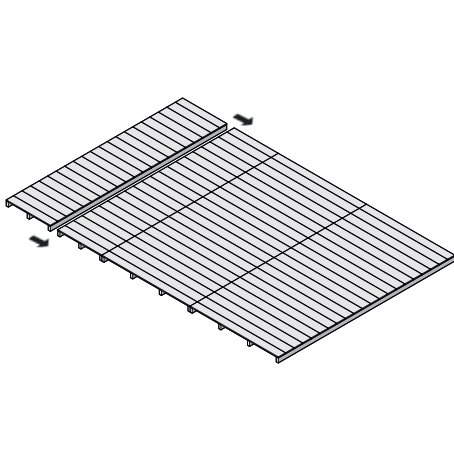

1b SIDE PANELS



Start at a back corner. See the section layout on page 4 to confirm position. Secure the corner as shown below.

Repeat the process for the remaining panels and secure the panels together. Make sure that the bottom frame of the wall panel rests on the outer edge of the floor.

Secure the panels into place by screwing into the floor bearers.

EG. INSIDE CORNER

60MM SCREWS

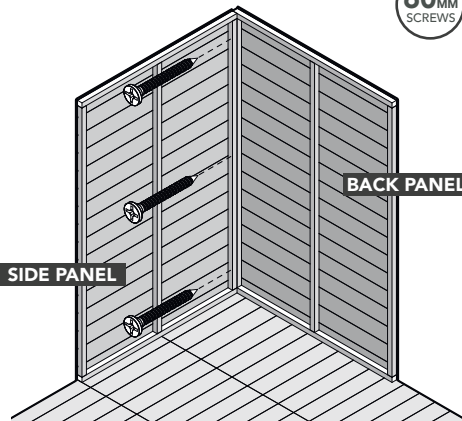

EG. BACK PANELS

60MM SCREWS



EG. INTO FLOOR BEARERS

60MM SCREWS



1c APEX SECTIONS



Attach the Internal Panels to the Single Door Panel and Plain Panel framework as shown below. Secure the panels together and into the bearer underneath.

Attach the front Apex Section screwing to the front panels as shown below.

Attach the back Apex Section to the back panels and attach the Internal Apex Section to the Internal Panels as shown below.

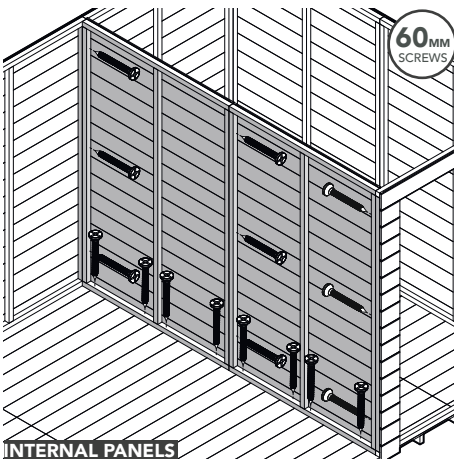

60MM SCREWS

INTERNAL PANELS

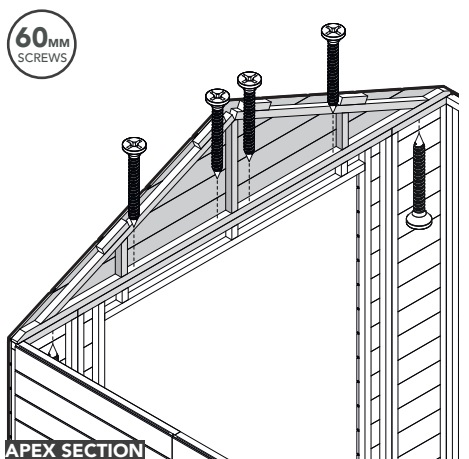

60MM SCREWS

APEX SECTION

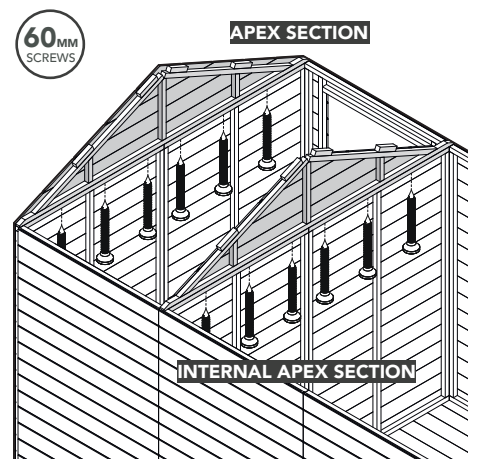

60MM SCREWS

APEX SECTION

INTERNAL APEX SECTION

2 COVER STRIPS & DOOR STRIPS



Attach the Cover Strips to the corners and adjoining panels. Ensure they are flush to the bottom edge of the panels as shown below.

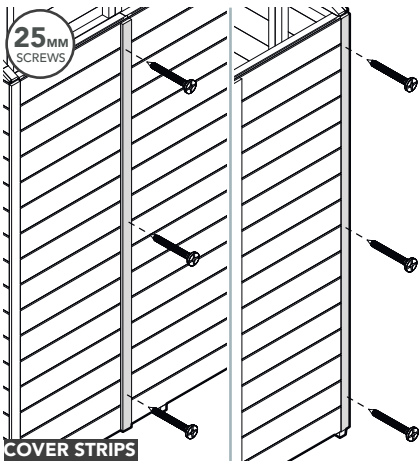

Attach the Joiner Cover Strips to the Apex Sections. Ensure they are flush to the Cover Strips.

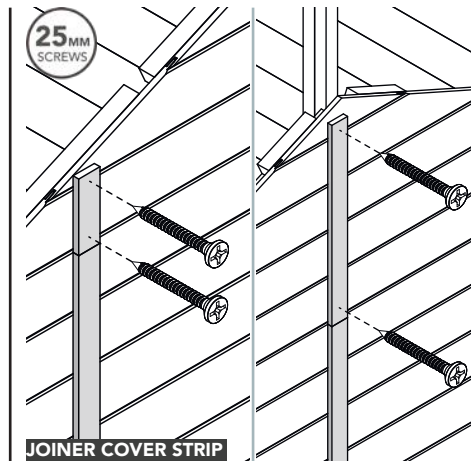

Secure the Door Weather Strips. Ensure they are in contact with the door batten and flush to the panel frame. Repeat the process for the single door opening.



3a ROOF TRUSS



Fix a Truss Support Block 535mm from the Internal Apex Section. Measure from the floor, using the measurement provided to position it at the correct height. Repeat for both sides.

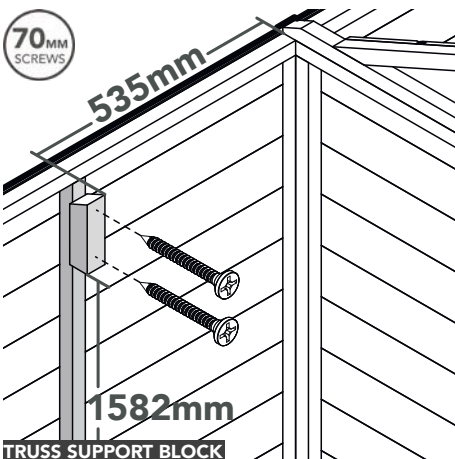

Position the Truss centrally onto the Truss Support Blocks. Secure the Truss to the Support Blocks.

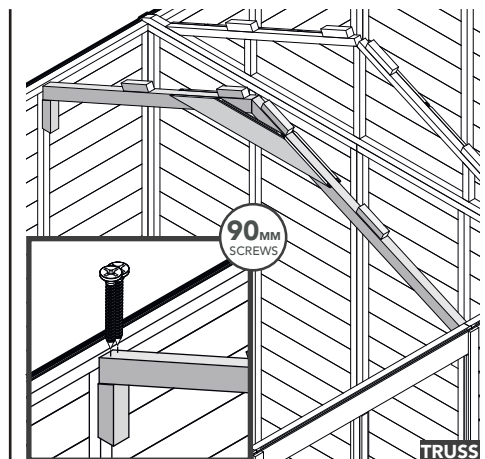

Position your back set of Roof Panels. The Roof Panels frame will hook onto the Truss battens as shown below. Ensure the Roof Panels sit centrally on the Truss.



3b ROOF ASSEMBLY



Secure the back Roof Panels to the battens attached to the Apex Section, Internal Apex Section and Truss. Ensure the Roof Panels are overhanging the Apex Section by 28mm.

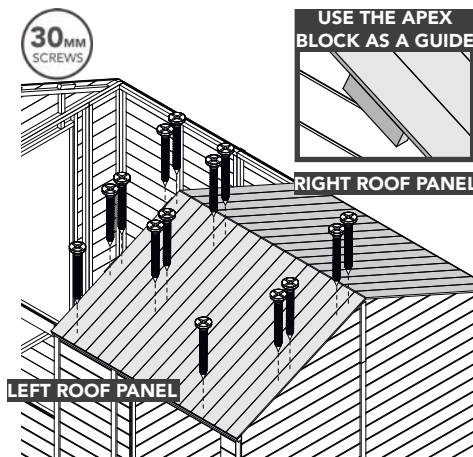

Secure the front Roof Panels to the battens attached to the Apex Section, and Truss.

Ensure the front Roof Panels are butt up against the back Roof Panels.

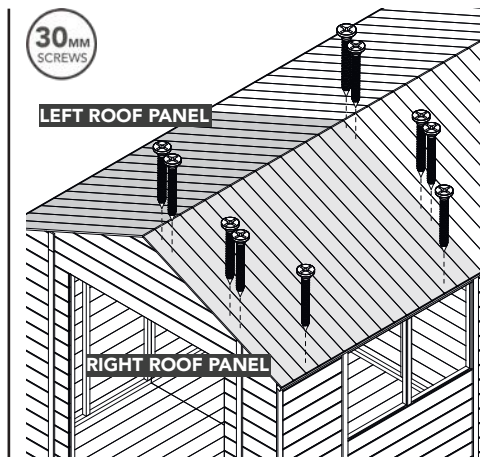

Measure out 4 equal lengths of felt. Overlap it on the top and around the edges. Fold at the corners. Tack to keep secure. Ensure 50mm of the felt covers the roof end battens. Tack from the bottom to the top.

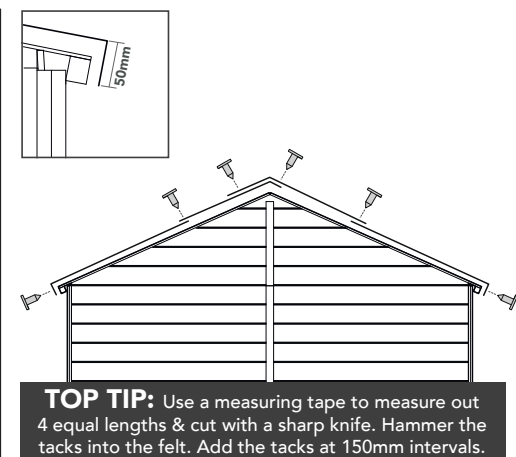

4 APEX BLOCKS, FASCIAS & FINIALS

PRE-DRILL WITH 2MM BIT FOR ALL STEPS BELOW.

Use the Apex Blocks to pin the felt in place when tacking. **Attach the Apex Blocks to Apex Sections.** Position and secure the Apex Blocks using the measurements provided.

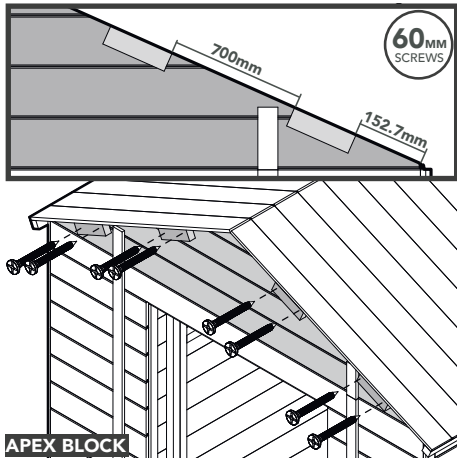

Secure the Fascias with screws to the attached Apex Blocks as shown below.

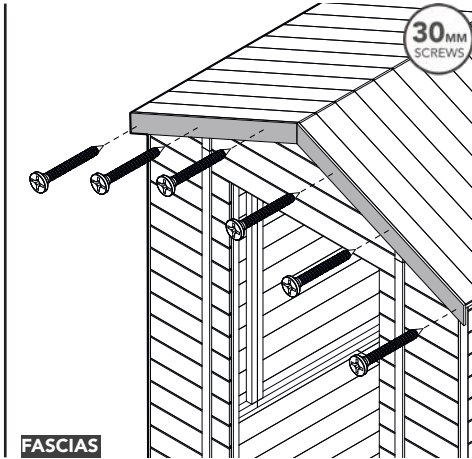

Secure the Finials with screws to the attached Fascias as shown below.

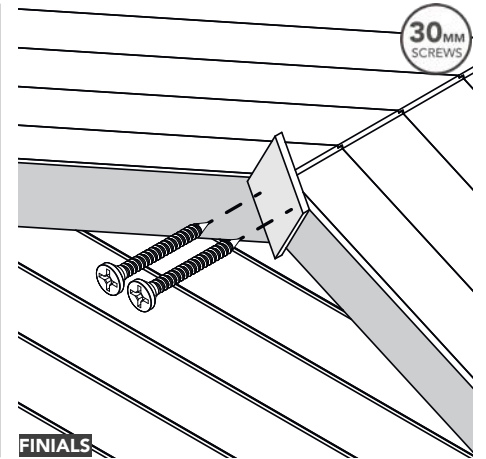

5 WINDOW ASSEMBLY

PRE-DRILL WITH 2MM BIT FOR ALL STEPS BELOW.

Attach the Cranked Hinges to the Window. Use the measurement provided as a positioning guide.

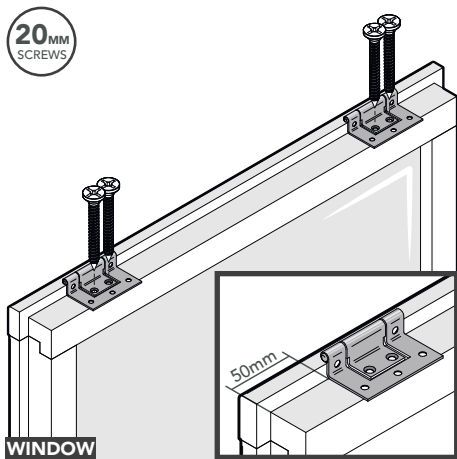

Secure the Window to the Window Panel framework. Ensure the pin on the hinges hook onto the T&G board on the front of the Window Panel and the window can open easily before securing into place.

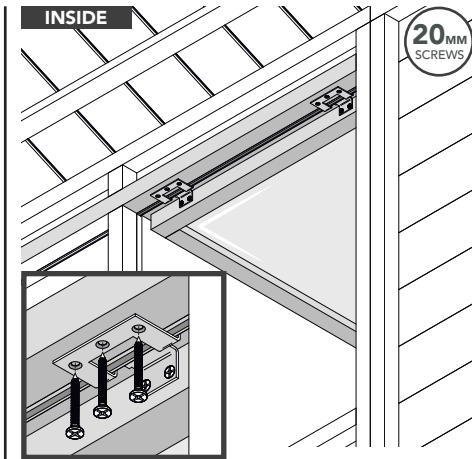

Secure the Casement Stay & Pins to the Window and interior sill. Secure the Casement Stay with its supplied screws and use it to position the pins underneath. Mark out first to ensure they align.

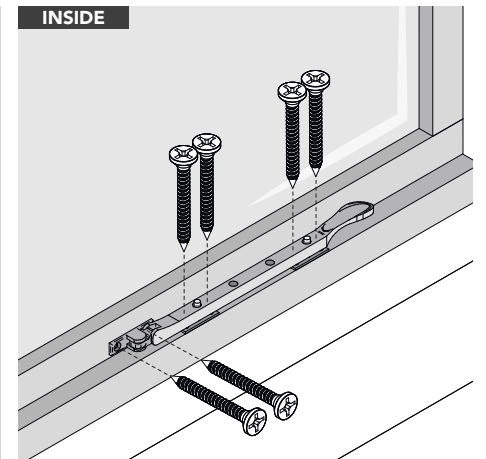

6a DOOR PREPARATION

PRE-DRILL WITH 2MM BIT FOR ALL STEPS BELOW.

Before attaching the double doors, **screw the Slamming Strip** onto the 'closed' door. Ensure you screw through the slamming strip into the door framework as shown below.

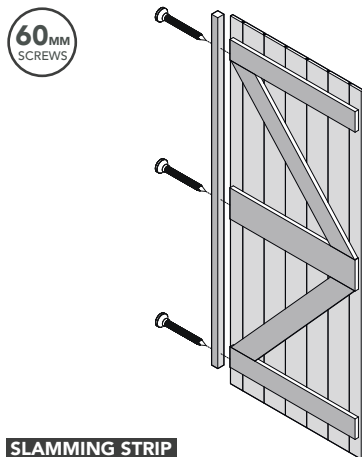

Make sure the outer face of the notch on the hinge is in line with the door edge.

HINGE POSITION

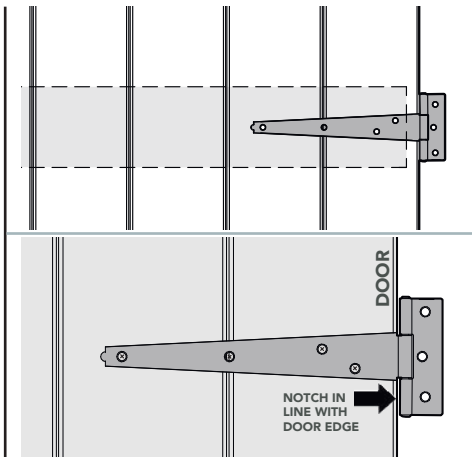

Position and **attach the hinges** to the framework behind on the Door. **Please take note of the hinge position.**

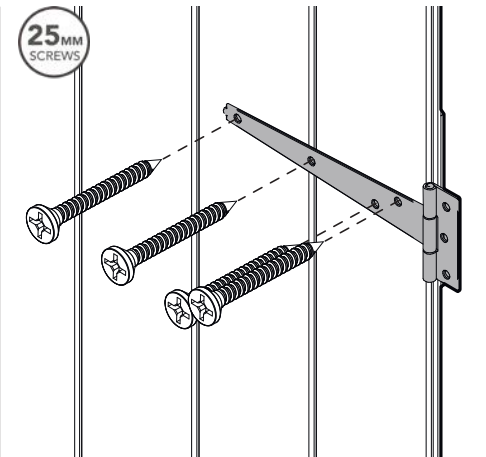

6b DOUBLE DOOR ASSEMBLY



Place the Doors into the opening, ensuring they're level. Make sure the hinges are up against T&G boards and fix into place.

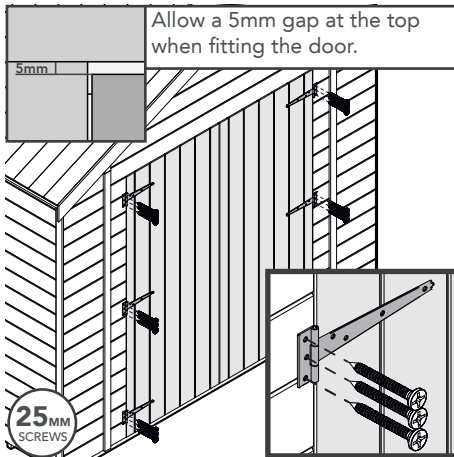

Fix the Lock Block flush to the corner of the framework on the back of the 'opening' Door (opposite to the door with the Slamming Strip attached).

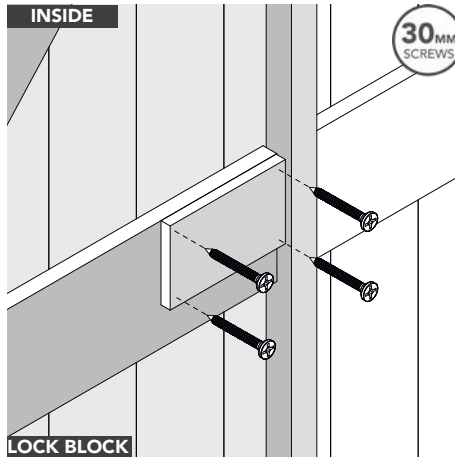

Use a 16mm drill bit for the Door Handle hole. Use the Escutcheon as a guide with 5-8mm drill bits and drill 3 x holes to provide the hole for the key.

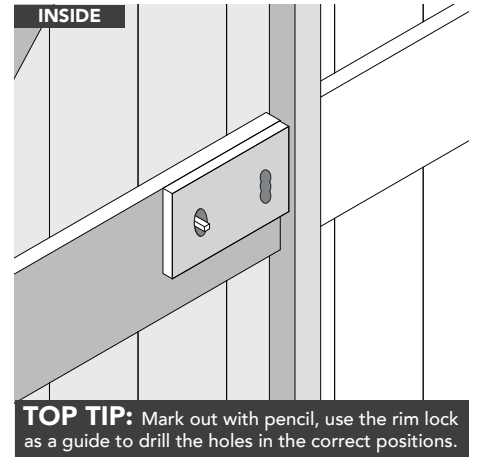

6c DOUBLE DOOR LOCK

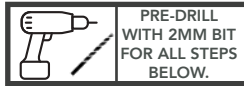

Secure the Rim Lock to the Lock Block with its supplied fixings. Ensure to hook the Rim Lock over the edge of the Lock Block. Thread the spindle through to attach the Handle.

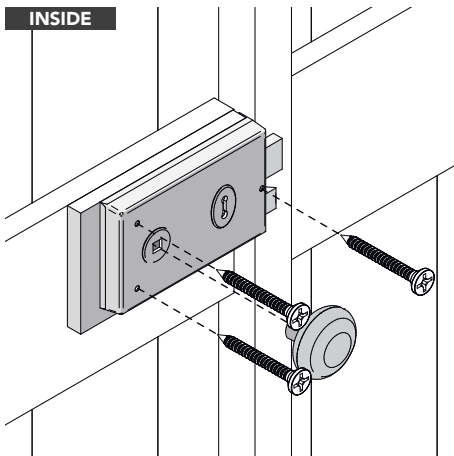

Attach the Door Handle and Escutcheon to the external face of the 'opening' Door using their supplied fixings.

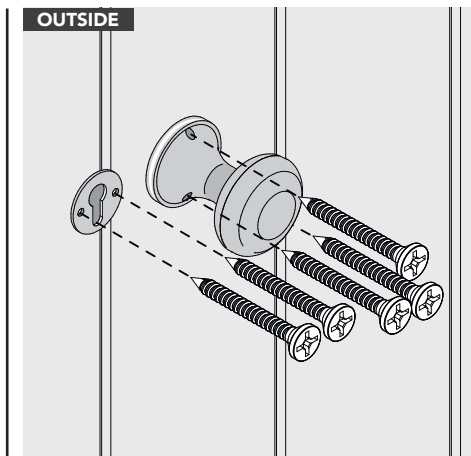

Position and secure the Rim Lock Receiver to the Slamming Strip. Test the key to ensure the lock works accordingly.

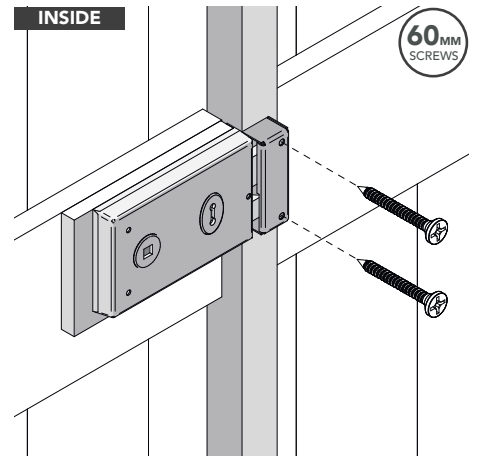

6d DOUBLE DOOR FIXINGS

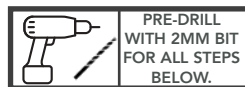

Fix a Barrel Bolt to the top of the Slamming Strip with its supplied fixings as shown below.

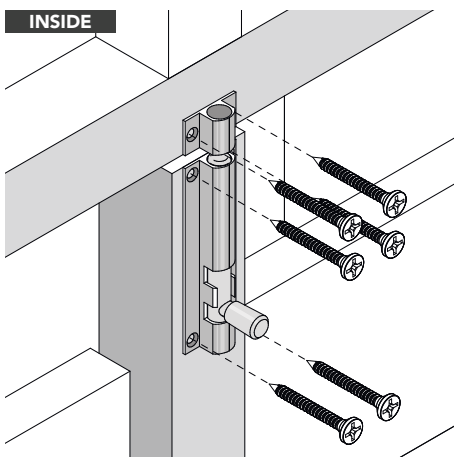

Fix a Barrel Bolt to the bottom of the Slamming Strip with its supplied fixings as shown below.

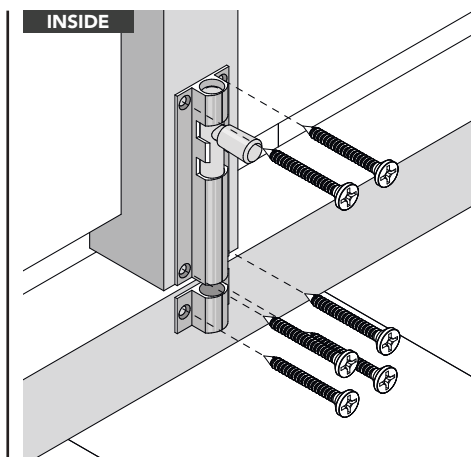

Attach a turn button at the top and bottom of the 'closed' door.

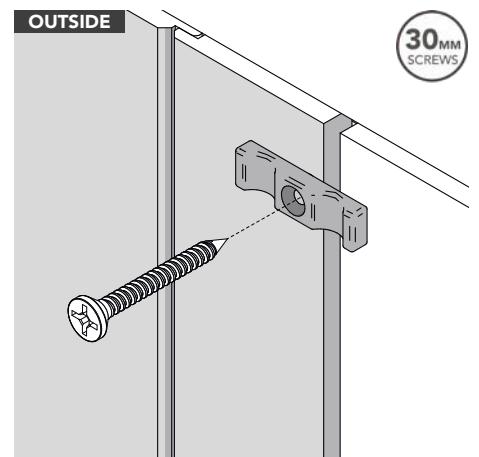

7a SINGLE DOOR ASSEMBLY



Place the Door into the opening, ensuring it's level. Make sure the hinges are up against T&G boards and fix into place.

Fix the Lock Block flush to the corner of the framework on the back of the Door. Repeat the process for drilling the Lock Block.

Secure the Rim Lock to the Lock Block with its supplied fixings. Ensure to hook the Rim Lock over the edge of the Lock Block. Thread the spindle through to attach the Handle.

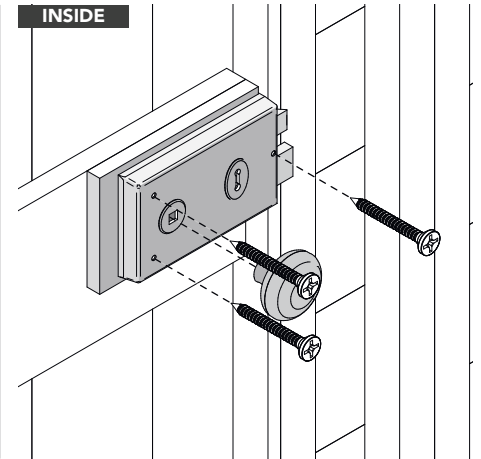
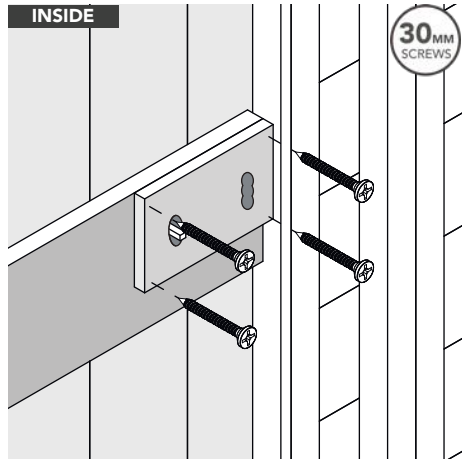
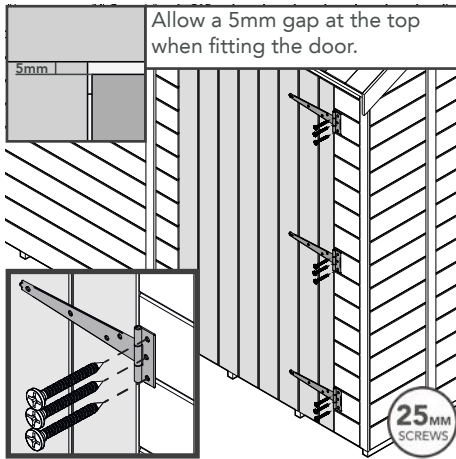

7b SINGLE DOOR FIXINGS

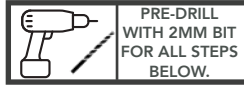

Attach the Door Handle and Escutcheon to the external face of the Door using their supplied fixings.

Position and secure the Rim Lock Receiver to the framework. Test the key to ensure the lock works accordingly.

Attach a turn button at the top and bottom of the Door Panel.

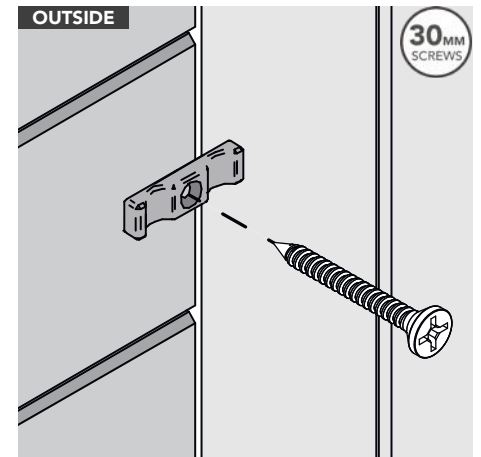
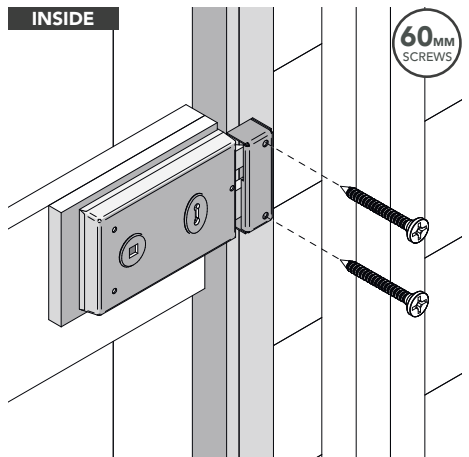
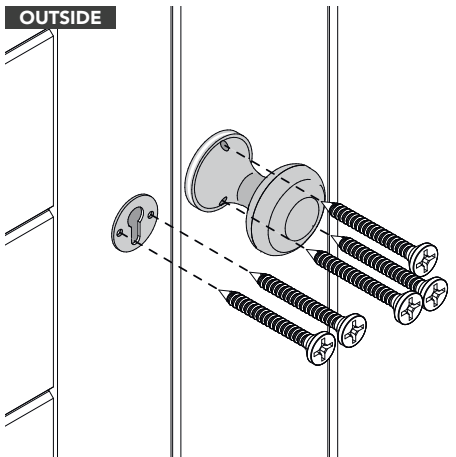

TREATED TIMBER CONTAINING A BIOCIDAL PRODUCT CONTROL OF WOOD DESTROYING ORGANISMS

Active Ingredients - Basic Copper Carbonate, Benzalkonium Chloride. (Pressure Treated Sheds)

For use in above-ground and in-ground conditions. Wear gloves when handling freshly treated wood. Avoid breathing wood dust, treated or untreated. Do not burn off-cuts.

CHECK YOU HAVE ALL YOUR PARTS.

(The parts do not have codes on them. They are listed below should you need to order one.)

The components provided may be heavy. Please lift with caution and with a minimum of 2 people.

T&G Apex Combo 8' x 12' - 2 Windows (TPAC812DDM)			
Label	Part Code	Description	No.
A	TPMOD328	Section A - Plain Side (328x1831mm)	2
B	TPMOD557	Section B - Plain Side (557x1831mm)	2
C	TPMODPP1147	Section C - Plain Side (1147x1831mm)	2
D	TPMODPP1180	Section D - Plain Side (1180x1831mm)	3
E	TPMODDW	Section D - Window Panel (1180x1831mm)	1
F	TPMODDP	Section E - Single Door Panel (1180x1831mm)	1
G	TPMODINT1147	Section F - Internal Plain Side (1147x1798mm)	2
H	TPMODDDP	Section G - Double Door Panel (1704x1831mm)	1
I	TPMOD108FL1180	Floor (1180x70x2360mm)	2
J	TPMOD108FL590	Floor (590x70x2360mm)	2
K	TPMODGAB2360	Apex Section (538x2360mm)	2
L	TPMODGABINT2360	Internal Apex Section (511x2360mm)	1
M	45121820PPT	Cover Strip (45x12x1820mm)	12
N	45120140PPT	Joiner Cover Strip (45x12x140mm)	2
O	45120500PPT	Joiner Cover Strip (45x12x500mm)	1
P	33121631PPT	Door Weather Strip (33x12x1631mm)	4
Q	45450155PAI24PT	Truss Support Block (45x45x155mm)	2
R	TPMOD108TRUSS	Truss (585x2294mm)	1
S	TPMOD128RHRF	Right Roof Panel (1372x1814mm)	2
T	TPMOD128LHRF	Left Roof Panel (1372x1814mm)	2
U	45280150PPT	Apex Block (45x28x150mm)	8
V	95121420PAI124PT	Fascia (95x12x1420mm)	4
W	FIN20010512PT	Finial (105x12x200mm)	1
X	FOTAGFIN	Finial with Badge (105x12x200mm)	1
Y	TPASWIN	Window (558x695mm)	2
Z	TPDR1705	Double Door (700x1705mm)	2
AA	MTGSH86DR	Single Door (883x1705mm)	1
AB	33331626PPT	Slamming Strip (33x33x1626mm)	1
AC	95150150PPT	Lock Block (95x15x150mm)	1
AD	Felt - Please contact our aftersales team with your product code if you are missing your felt.		1

Use the labelled components to help identify the part code and description.

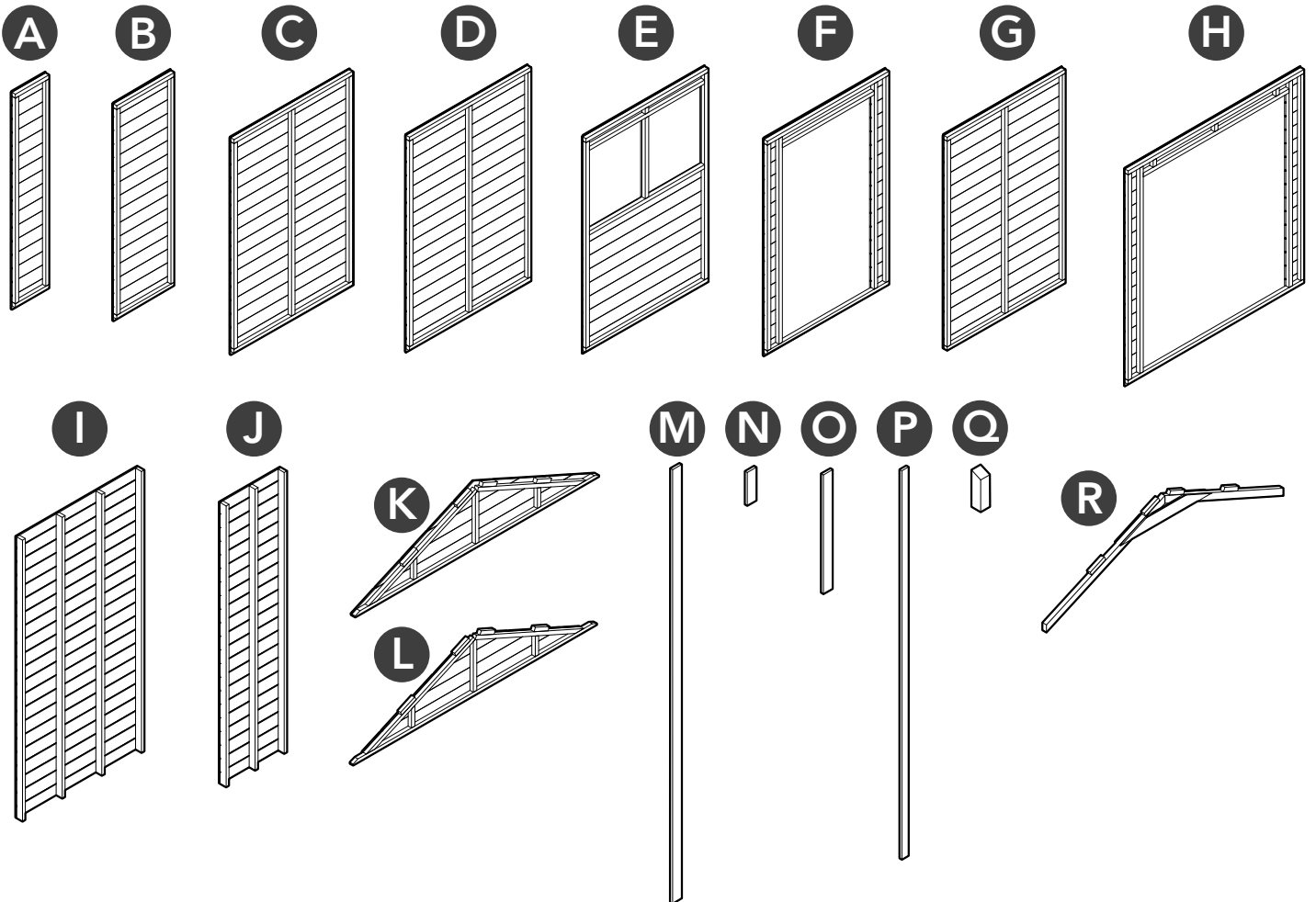

S

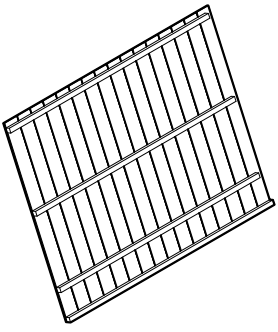

T

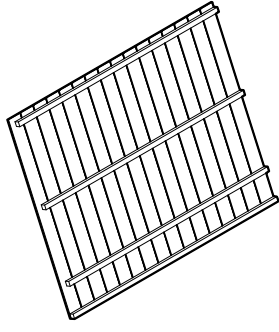

U



V

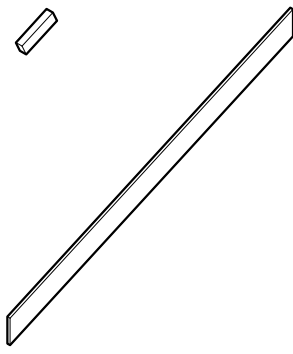

W



X

Y

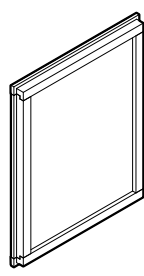

Z

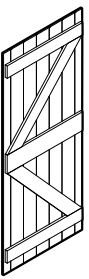

AA

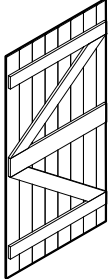

AB



AC

