

040190

EQUIPMENT



2 people



Measure



Drill



Level



Angle
bracket

PARTS

1

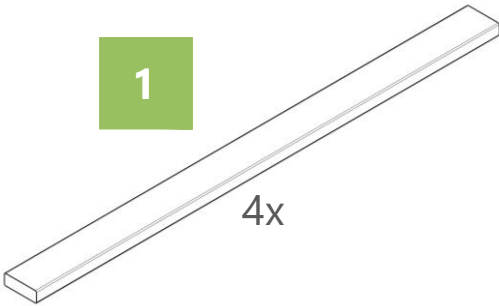

4x

2

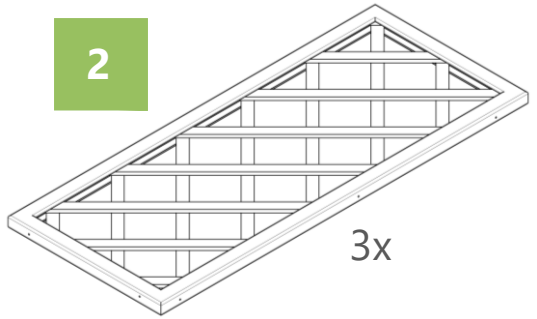

3x

3

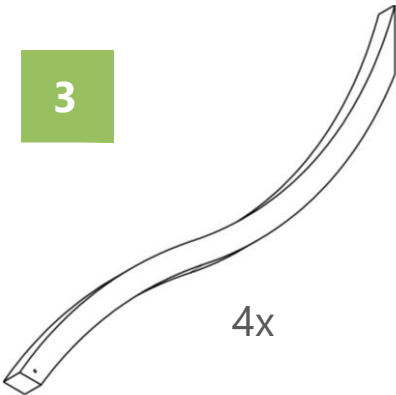

4x

4

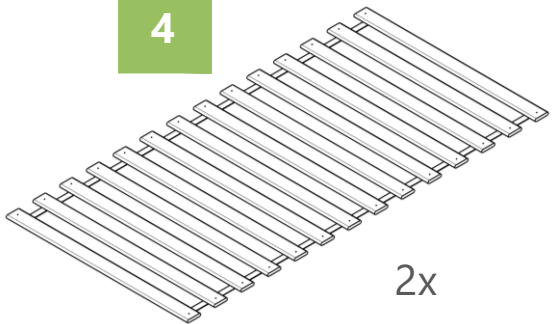

2x

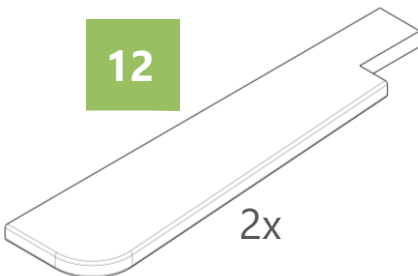
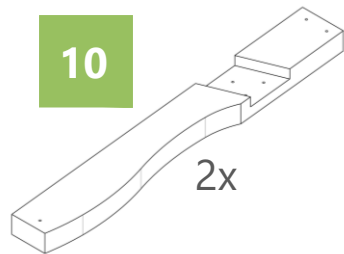
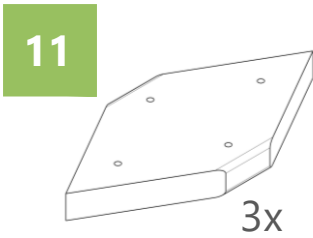
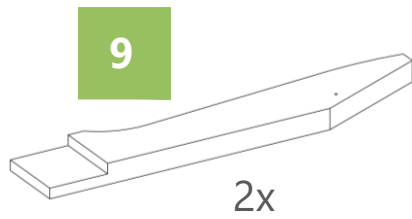
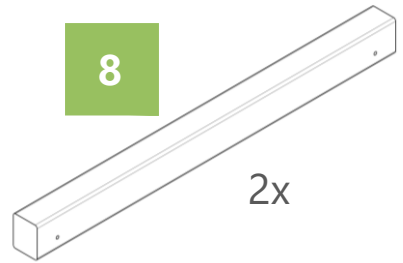
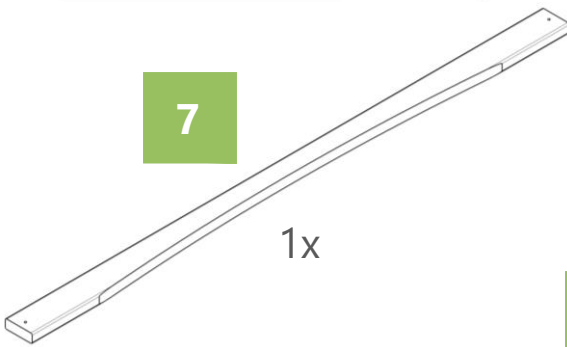
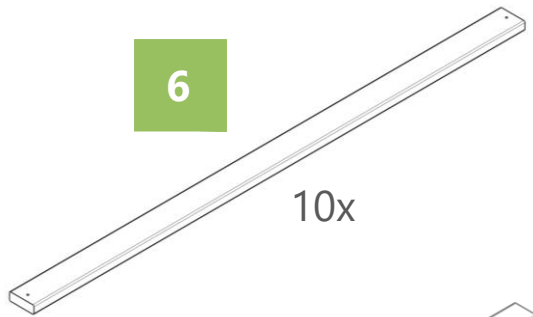
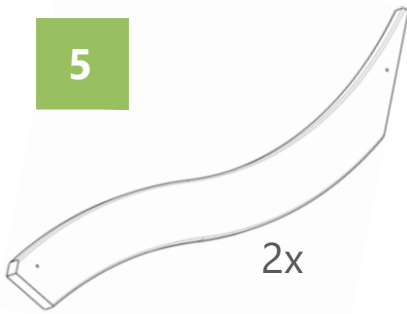

FITTINGS

A

1x

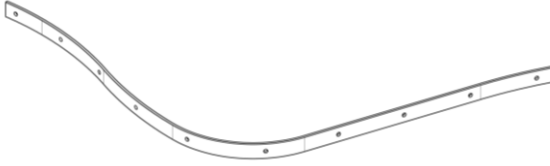

B

4x

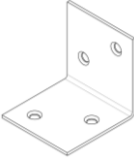

SCREW BIT: PZ2

C

26x



4x20 mm

D

6x



4x25 mm

E

12x



4x30 mm

F

29x



4x40 mm

G

16x



4x50 mm

H

18x



4x60 mm

SCREW BIT: PZ1

I

20x



3x16 mm

Step 1

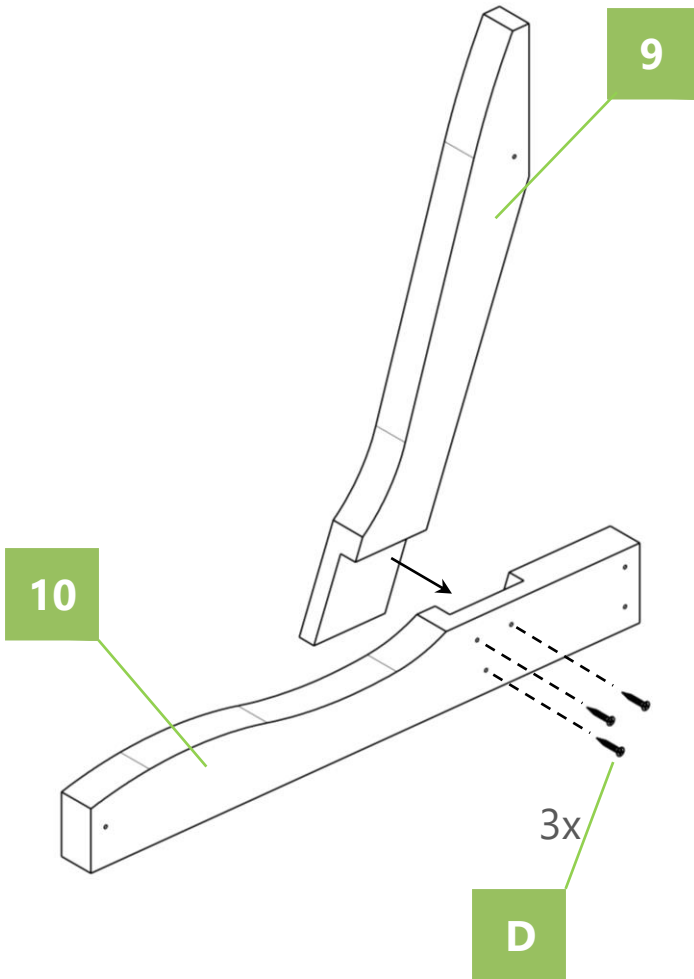

Assemble 2 such segments

Step 2

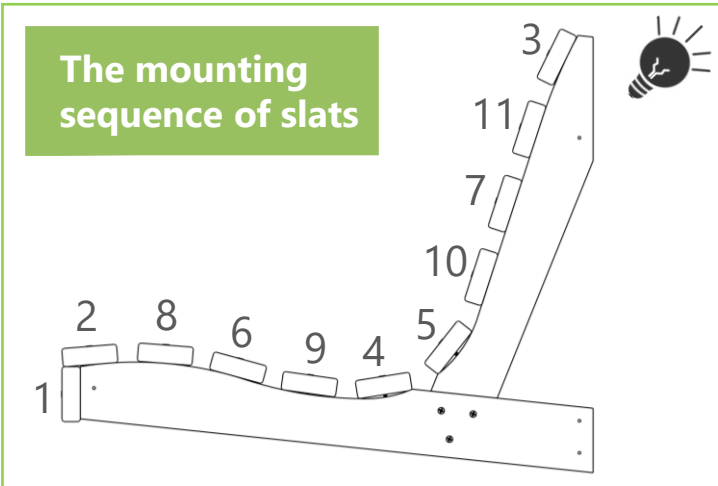
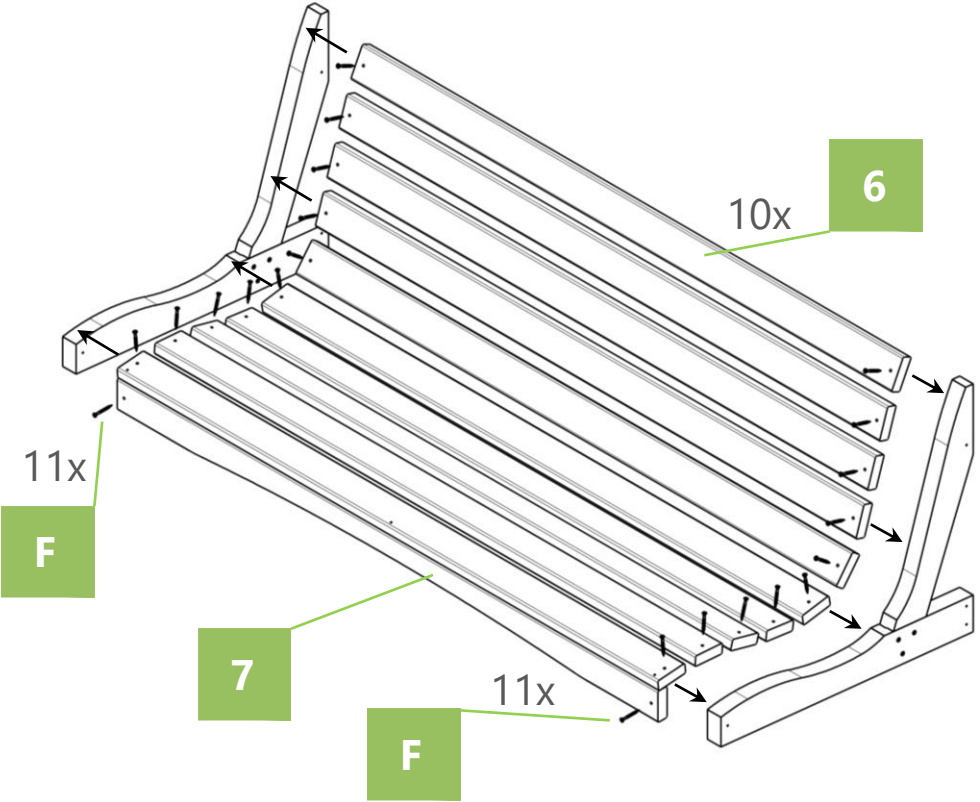

Step 3

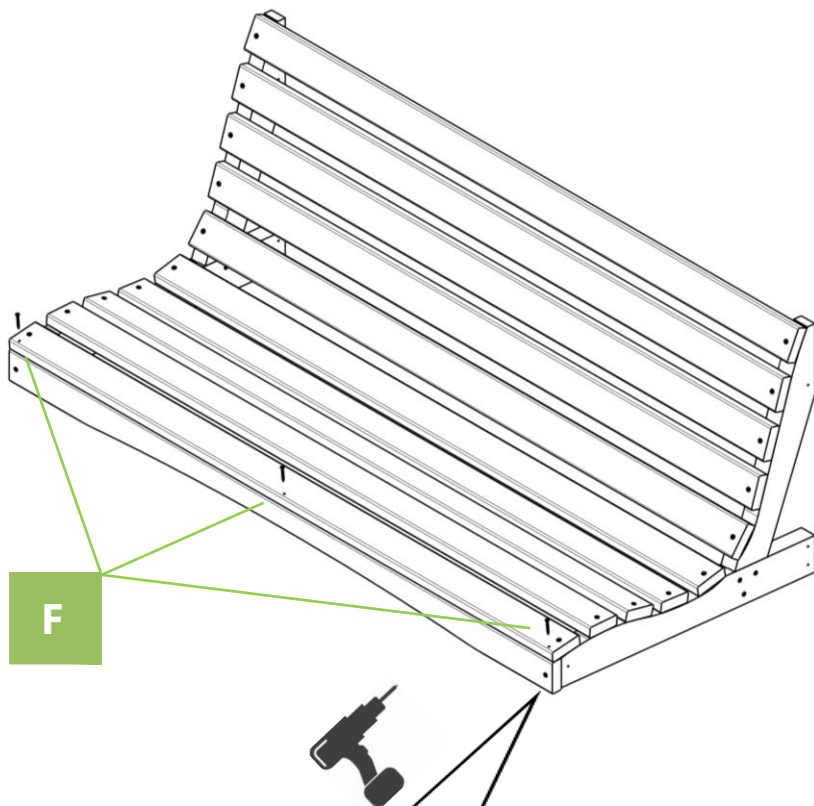

Pre-drill holes for screws in the 2nd slat.

Drill bit: **Ø4**

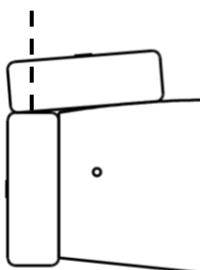

Step 4

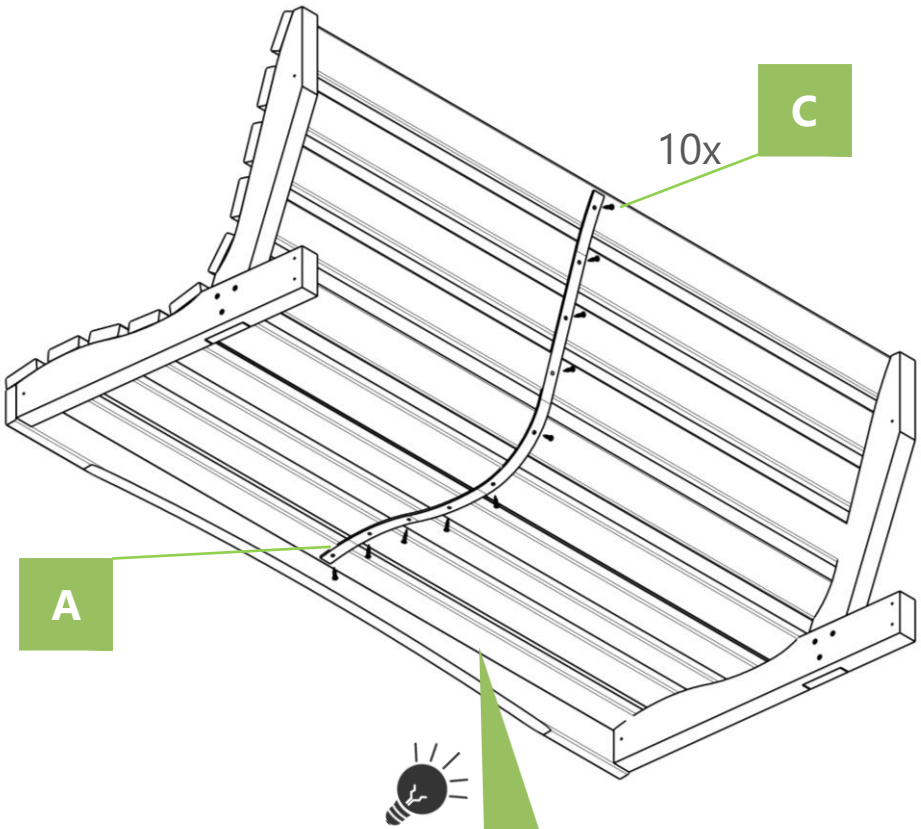

Start mounting the steel flat bar from the 2nd slat from the bottom (see step2 – slat no. 2). Adjust it to the profile of the bench by bending it.

Step 5

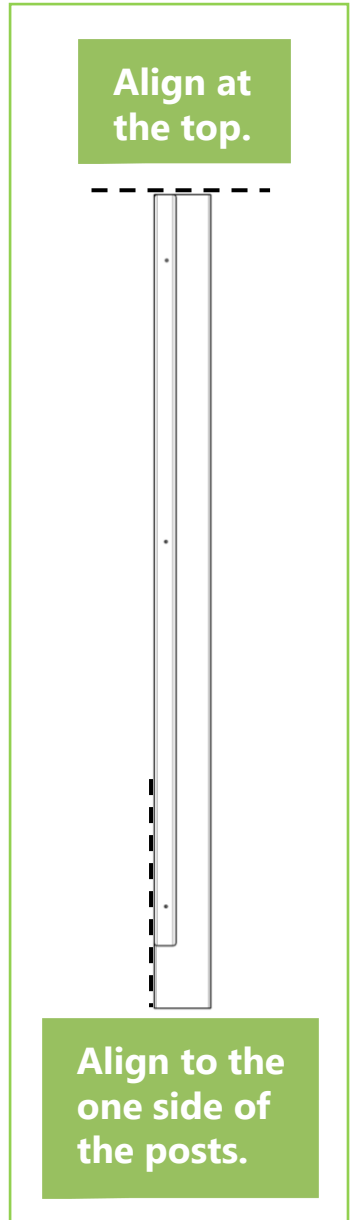
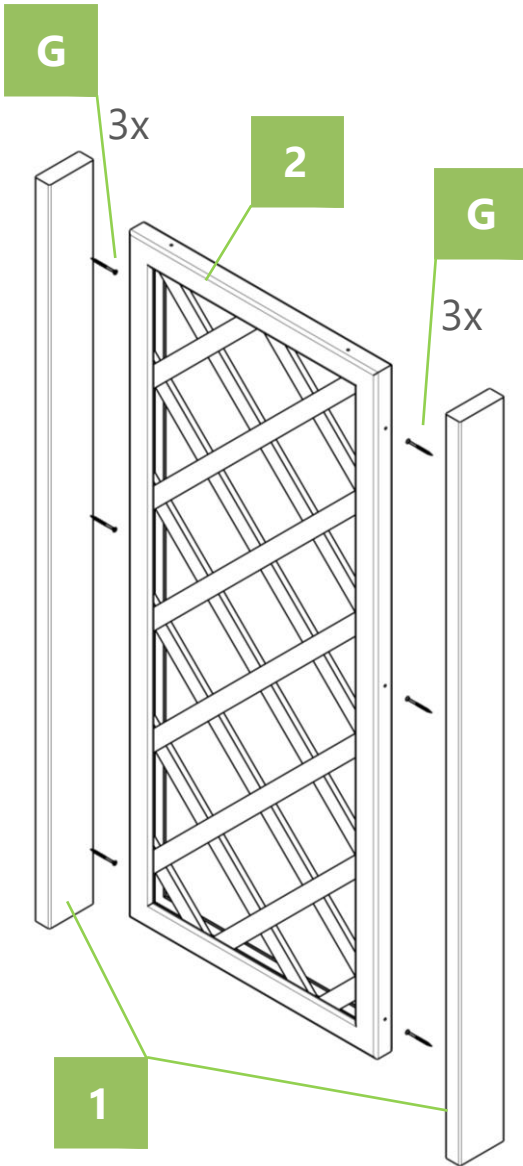

Step 6

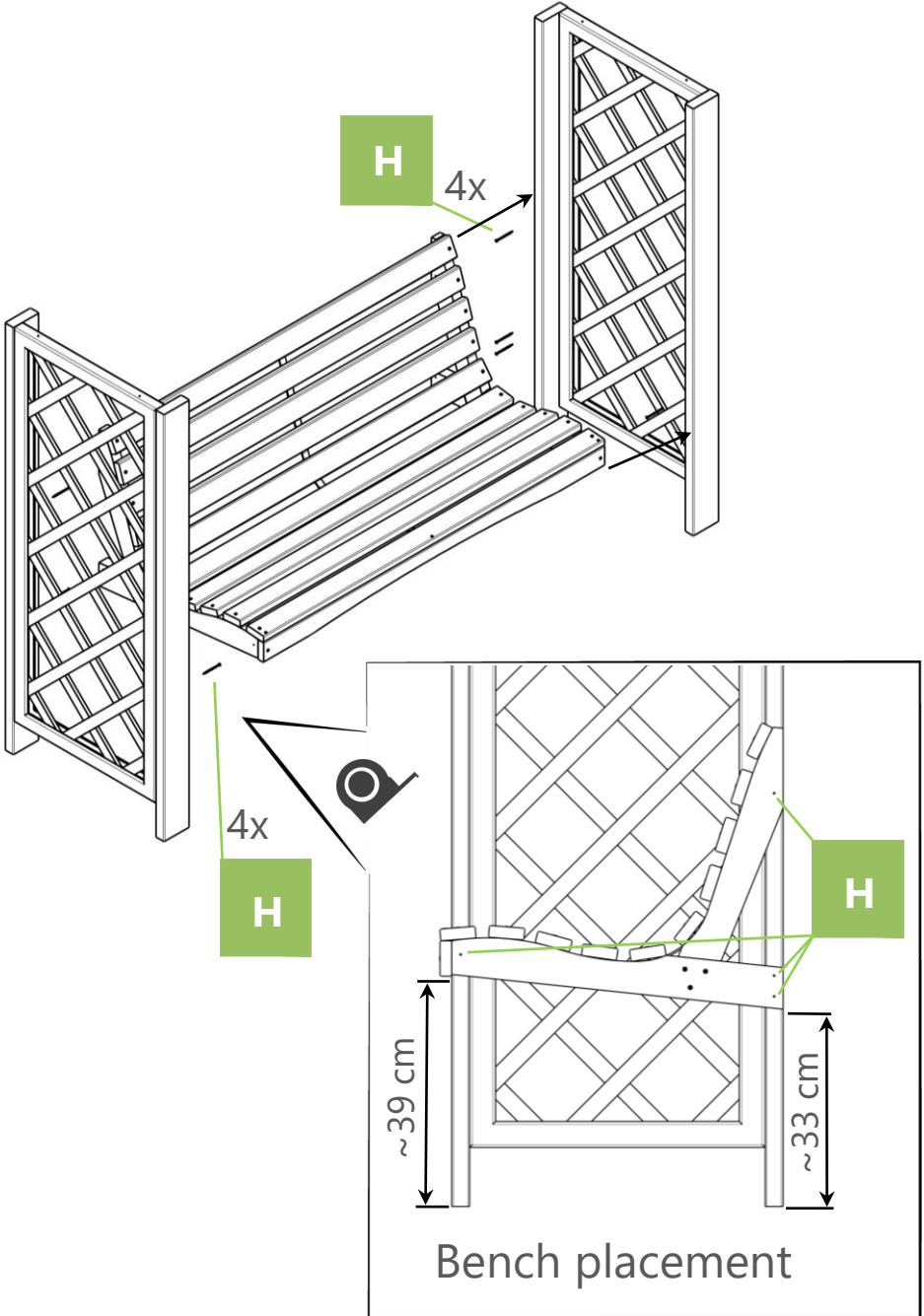

Step 7

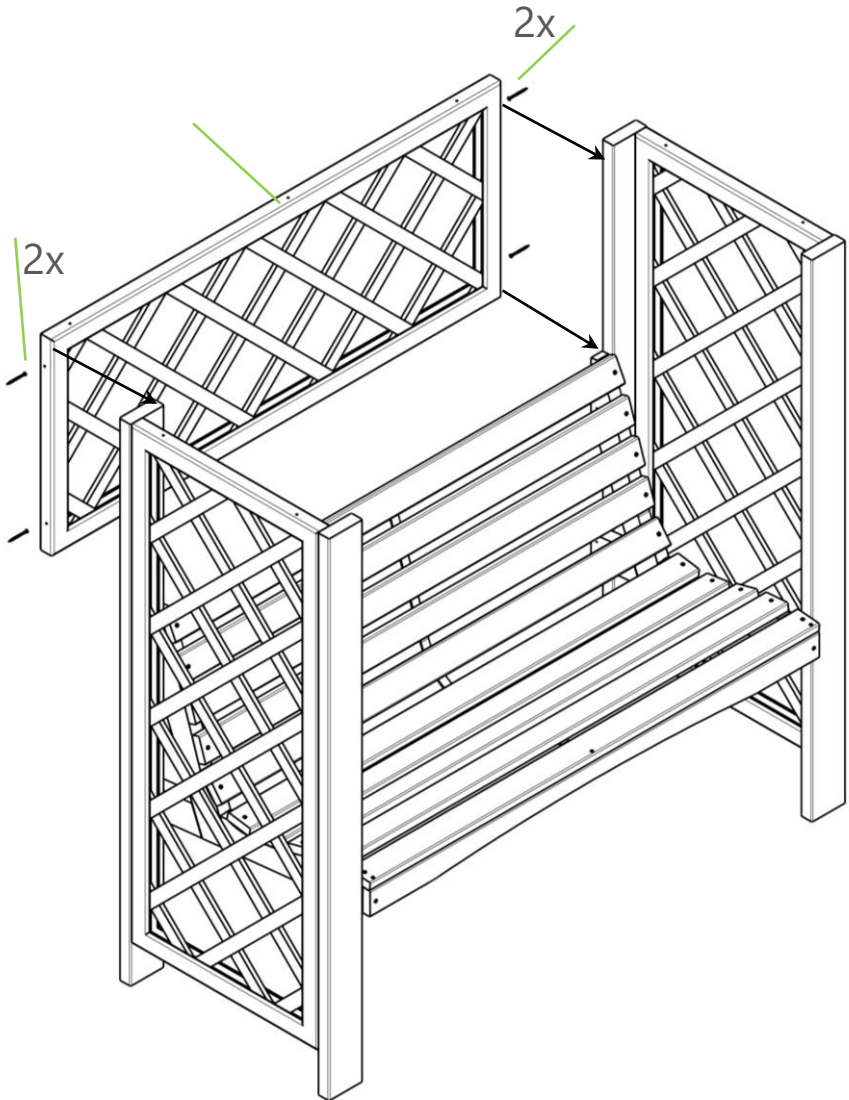

Step 8



Pre-drill holes
Drill bit: **Ø4**

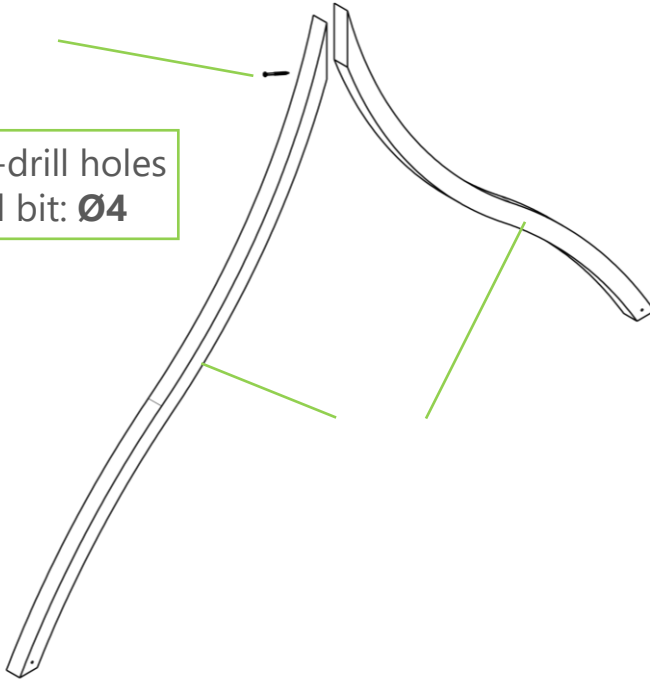

Assemble 2 such segments

Step 9

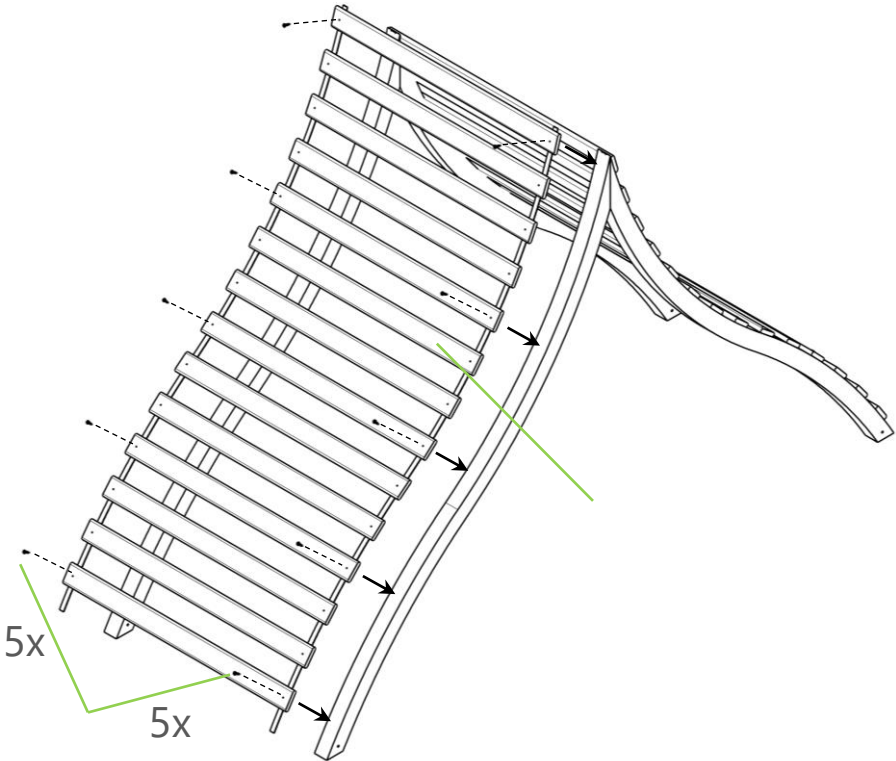

Pre-drill holes
Drill bit: Ø3

Step 10

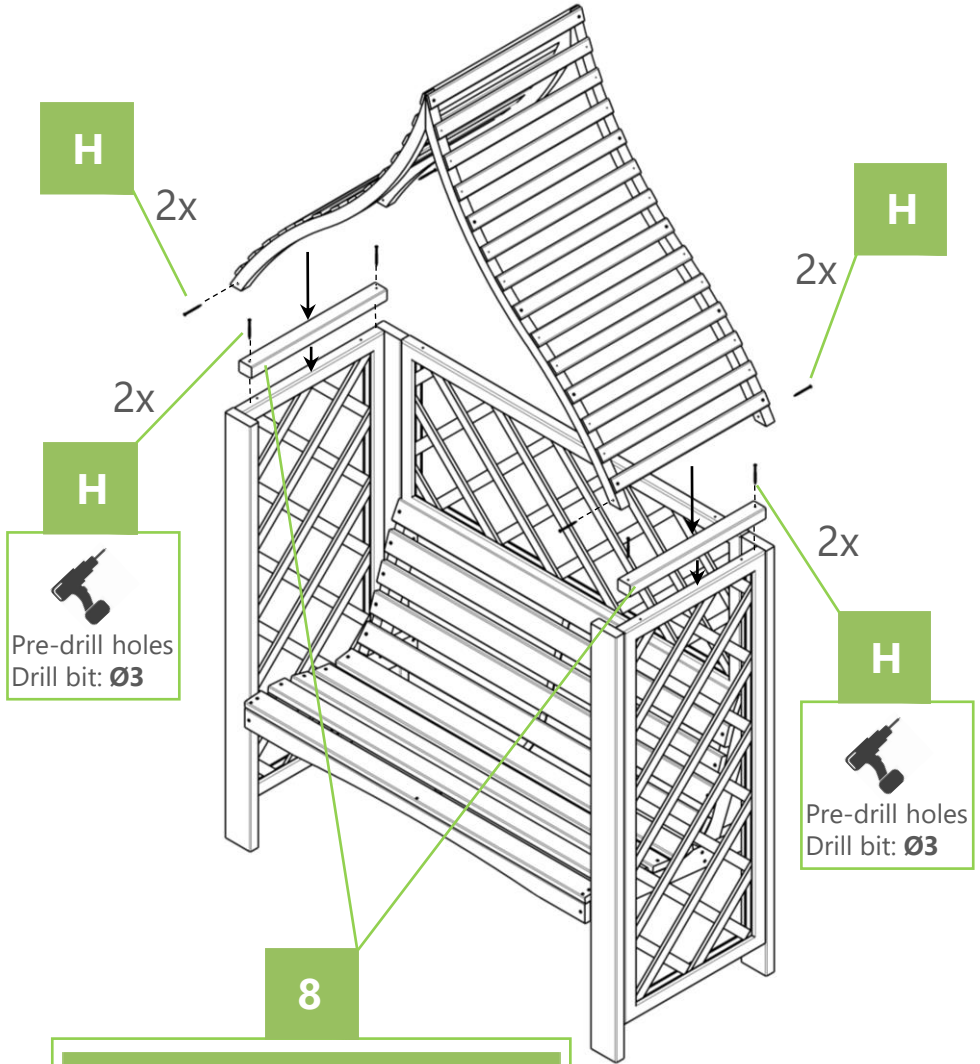

**Part 8 placement:
Align with the post at the back**

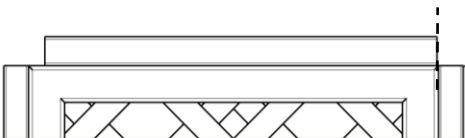

Step 11

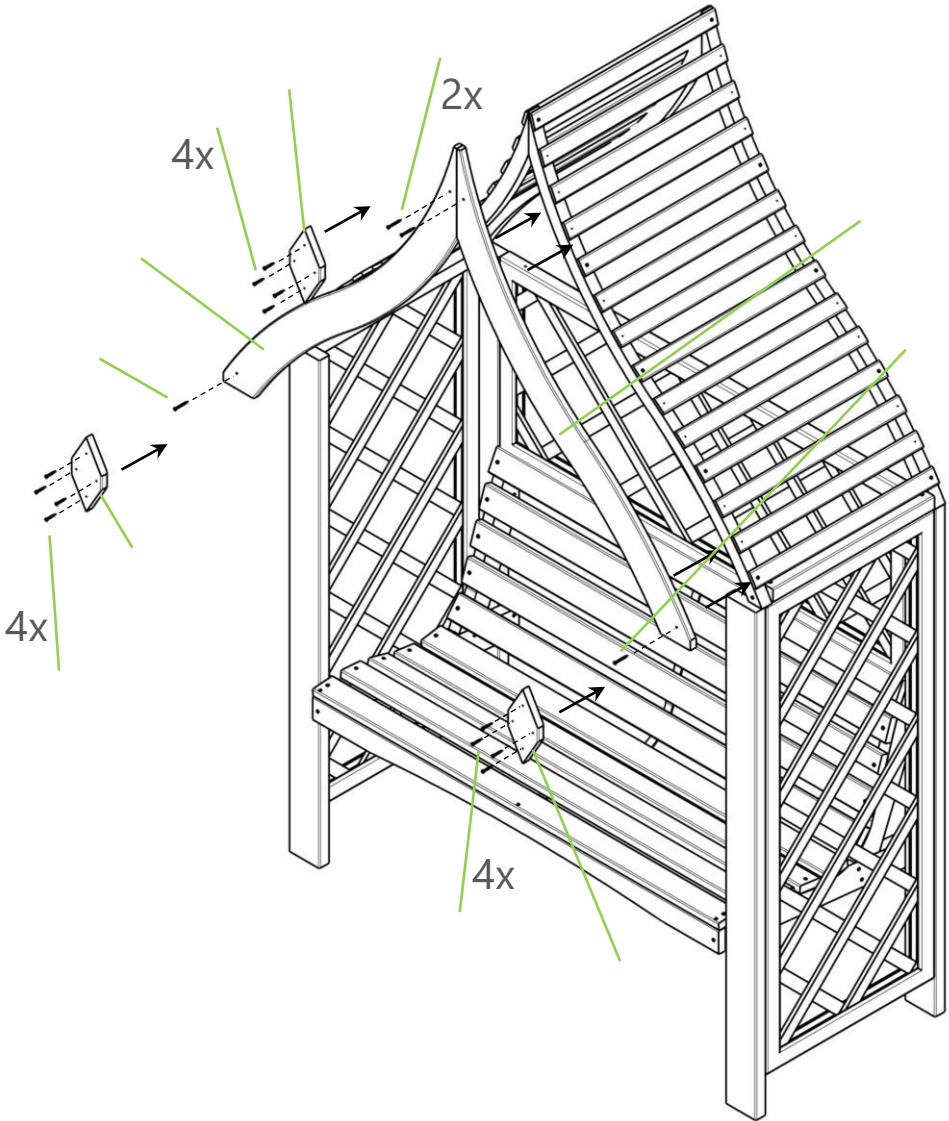

Step 12

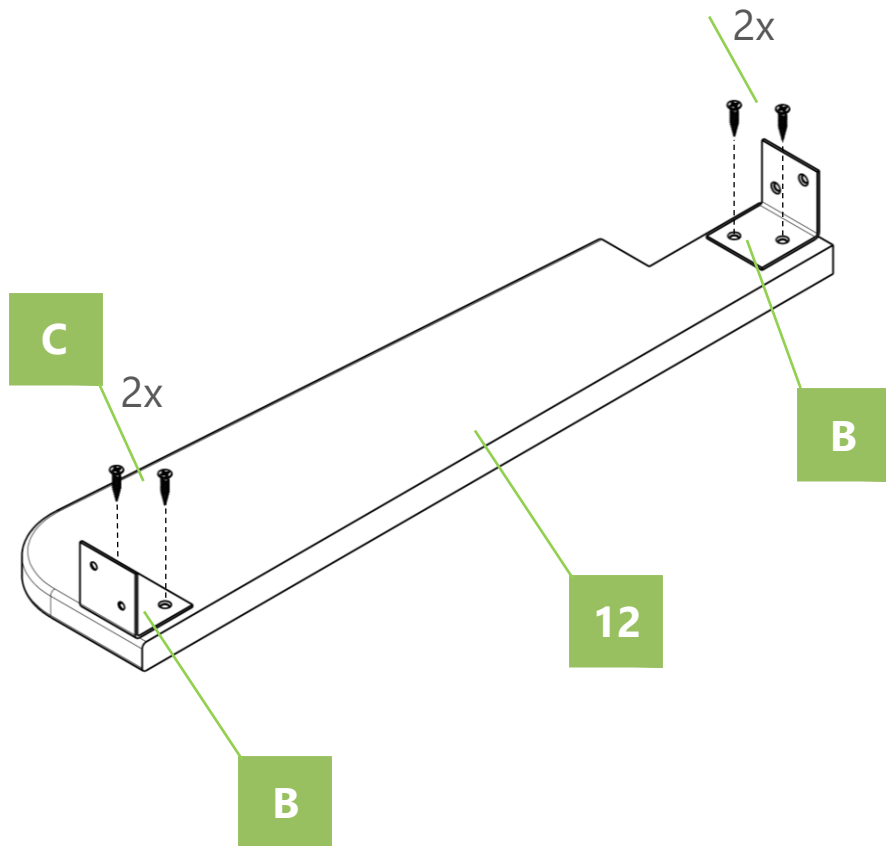

Step 13

