

Product size:

Armchair: W71*D65*H60/75 cm

Footstool: W60*D60*H32/40 cm

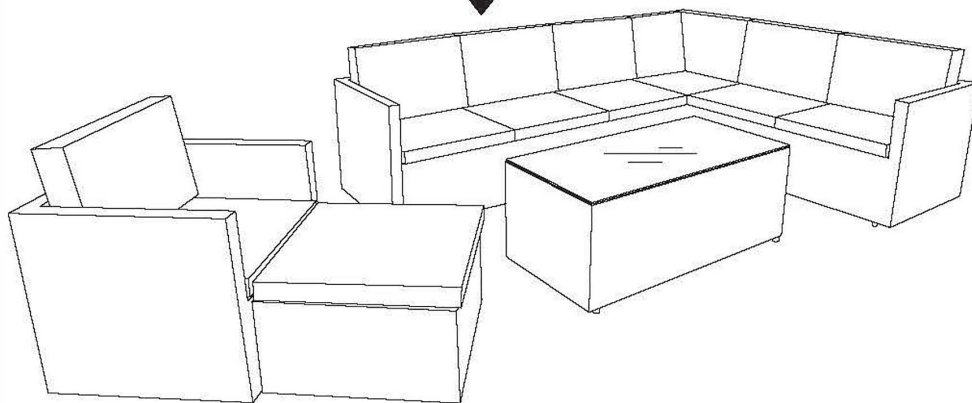
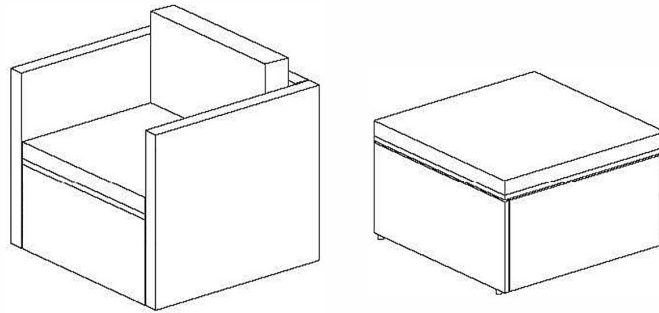

Furniture should be covered/stored whilst not in use to prolong its longevity.

(It should also be covered in adverse weather.)

The intended use of this product is for domestic use only.

Important, please retain for future reference.

Read carefully.



Armchair and Footstool for Berlin 6PCS Corner Lounging Sofa Set

Assembly Instructions

Before you start



Warnings

IMPORTANT, RETAIN FOR FUTURE REFERENCE READ CAREFULLY

See enclosed instructions for assembly, safety and care information.

Failure to follow the warnings could result in serious injury.

Handle heavy parts with care.

Ensure that this product is fully assembled as illustrated before use.

This product should only be used on firm, level ground.

Keep small parts out of reach of children.

Do not stand or climb onto this product.

This product is intended for **domestic use** only.

Furniture can be dangerous if incorrectly used. No liability will be accepted for damage or injury caused by incorrect use of this product.

✓ Dos

When you are ready to start, make sure that you have the right tools, plenty of space and a clean, dry area for assembly.

Unwrap all packaging materials and place the components on a suitable surface to prevent scratching your product.

Check all contents are present prior to assembly as per the parts list provided. In the event of problems or missing parts, please contact the seller.

Check all screws and bolts are tightened and inspect regularly.

Cover furniture when not in use to add additional protection to your product.

Store all cushions indoors after use as they are not waterproof.

During severe weather conditions, including high winds, rain, hail, thunderstorms, extreme heat and cold temperatures, the product should be stored inside in a cool, dry place.

To best preserve the synthetic rattan, please use a protective cover when your furniture is not in use. We would also recommend using a gazebo or parasol over your furniture during the summer period and prolonged sunny spells. This will help prevent harmful UV rays from damaging and discolouring the material.

Ensure that the product is clean and dry before storage.

Clean your product with a sponge and warm soapy water then wipe with a clean, dry cloth.

Cushions should be cleaned following the care instruction on the label.

Where instructions as to the; storage, commissioning, installation, use and maintenance of the goods or (if there is none) good trade practice are not followed and a defect arises this will void the 12 month manufacturer's guarantee on the product.

✗ Don'ts

Do not use scourers, abrasives, washing powders, chemical cleaners or any other substances containing abrasives since these substances can damage the product, including the glass panel.

Never tilt the chair during use.

Do not place very hot or very cold items on the glass surface unless adequately thick table-mats are used to prevent such items from coming into contact with the glass.

Do not use the glass as a chopping surface. Do not strike glass with hard or pointed items.

Do not strike the glass with hard or pointed items.

Do not use power tools to construct this product.

Do not use this product if parts are missing, damaged or worn.

Do not sit or lean on the table.

Do not stand or climb onto the product and do not use it as a ladder, as this could lead to it unbalancing and overturning.

Never drag furniture when moving it, always lift it.

Number of people required for assembly

Two people



Time to assemble

30 minutes

Tools required



Tips:

Do NOT fully tighten bolts before all components are connected.

Only fully tighten once you are satisfied with the alignment of all components.

Do not overtighten bolts.

www.royalcraft.co.uk



Armchair and Footstool for Berlin 6PCS Corner Lounging Sofa Set

Assembly Instructions

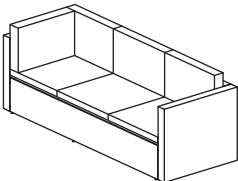
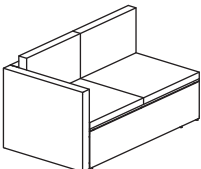
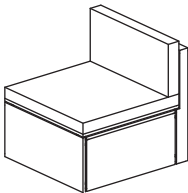
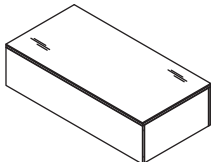
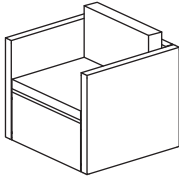
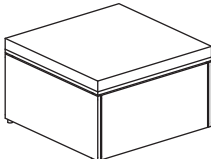

Please find the Components for the whole set.
This Carton contains Component 5 and 6.

No.	Diagram	Name	Qty.
1		3-Seater Sofa	1 PC
2		2-Seater Sofa	1 PC
3		Armless Sofa	1 PC
4		Coffee Table	1 PC
5		Armchair	1 PC
6		Footstool	1 PC

www.royalcraft.co.uk



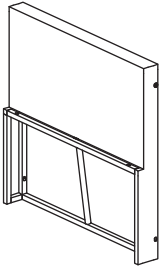
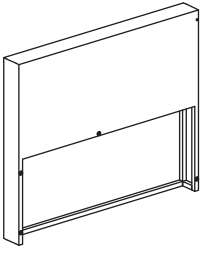
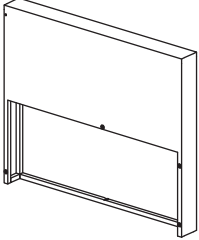
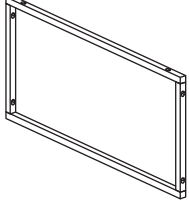
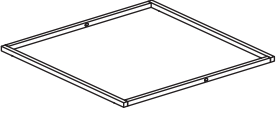

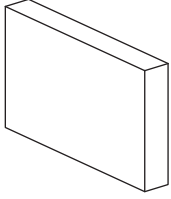
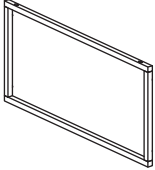
Armchair and Footstool for Berlin 6PCS Corner Lounging Sofa Set Assembly Instructions

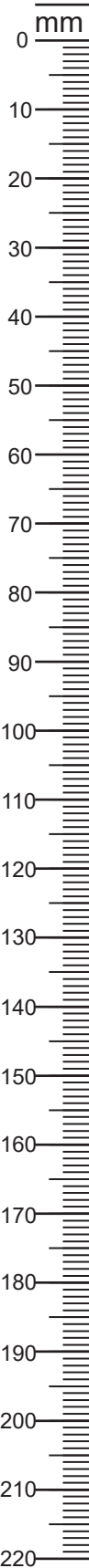
Parts, fixtures & fittings (not actual size)

Parts List					
Part No.	Diagram	Qty.	Part No.	Diagram	Qty.
A	 Backrest	1 PC	B	 Right Leg	1 PC
C	 Left Leg	1 PC	D	 Front Panel	1 PC
E	 Seat	1 PC	SC	 Seat Cushion	2 PCS
BC	 Backrest Cushion	1 PC	H	 Footstool Long Panel	2 PCS

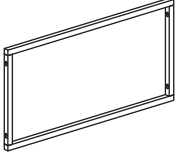
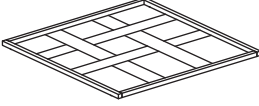

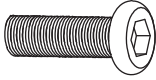
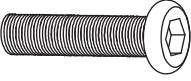
Armchair and Footstool for Berlin 6PCS Corner Lounging Sofa Set Assembly Instructions

I	 Footstool Short Panel	2 PCS	J	 Footstool Top Panel	1 PC
AK	 Allen Key	1 PC	F1	 Bolt Head Cap	2 PCS
N35	 M6*35mm Bolt	24 PCS	N70	 M6*70mm Bolt	2 PCS
F2	 Washer	26 PCS			

Armchair and Footstool for Berlin 6PCS Corner Lounging Sofa Set Assembly Instructions

Component 5 – Armchair: Assembly Steps

Step One

Loosely attach the Left Leg (C) and Right Leg (B) to the Backrest (A) using Washers (F2), Bolts (N35), Bolts (N70) and Bolt Head Caps (F1).

Please note different Bolt for different location.

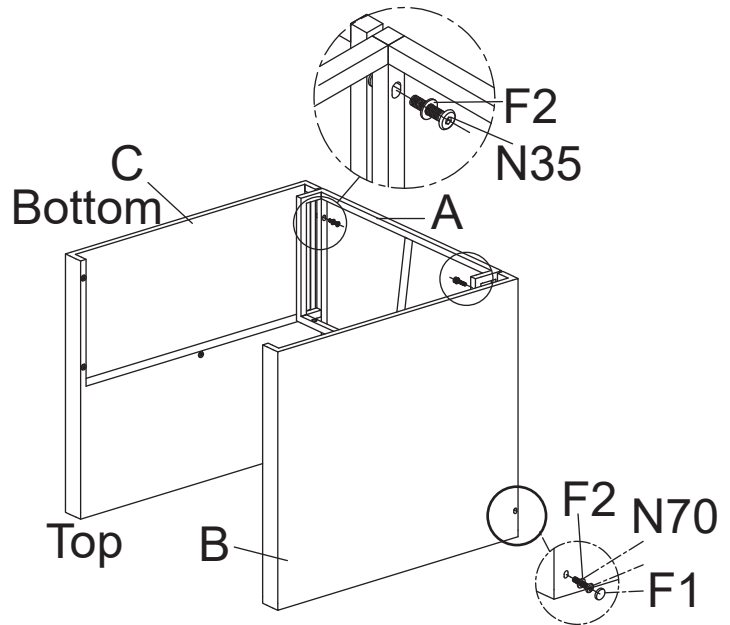

Step Two

Loosely attach the Front Panel (D) to above partly-assembled parts using Washers (F2) and Bolts (N35).

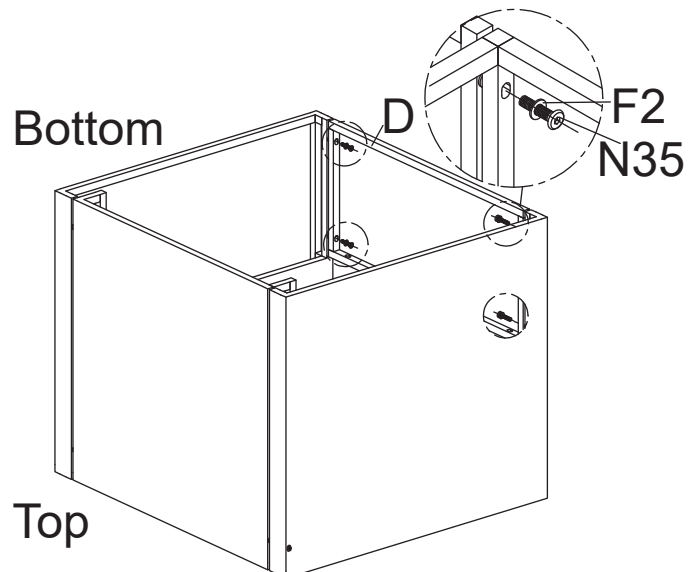

Armchair and Footstool for Berlin 6PCS Corner Lounging Sofa Set Assembly Instructions

Step Three

Loosely attach Seat (E) to above partly-assembled parts using Washers (F2) and Bolts (N35).

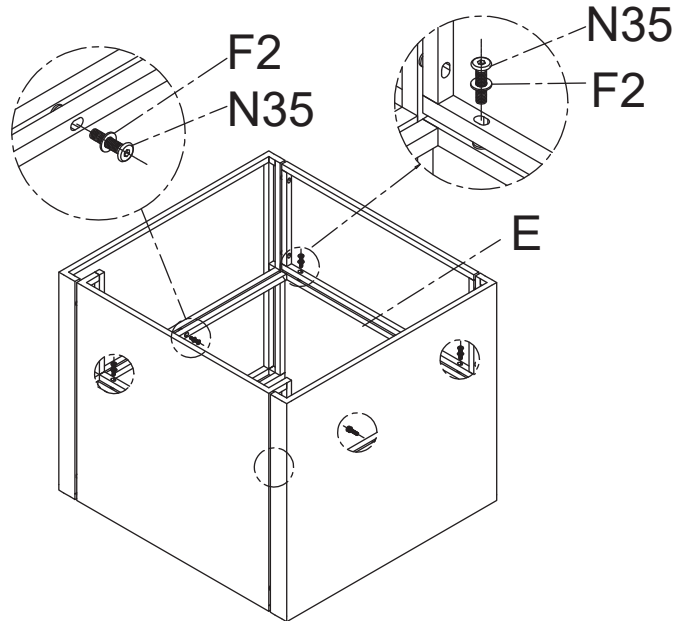

Step Four

With the help of another person, turn over and move the Armchair to the intended location for use, place the Seat Cushion (SC) and Backrest Cushion (BC) onto the Armchair.

Your Armchair is now ready for use.

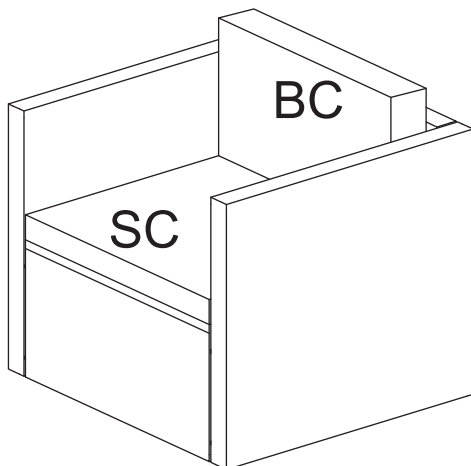
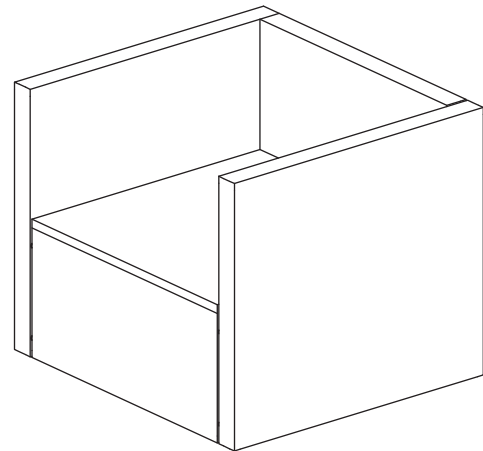

Armchair and Footstool for Berlin 6PCS Corner Lounging Sofa Set Assembly Instructions

Component 6 – Footstool: Assembly Steps

Step One

With the help of another person, loosely attach the Footstool Panels (I) and (H) to each other using Washers (F2) and Bolts (N35).

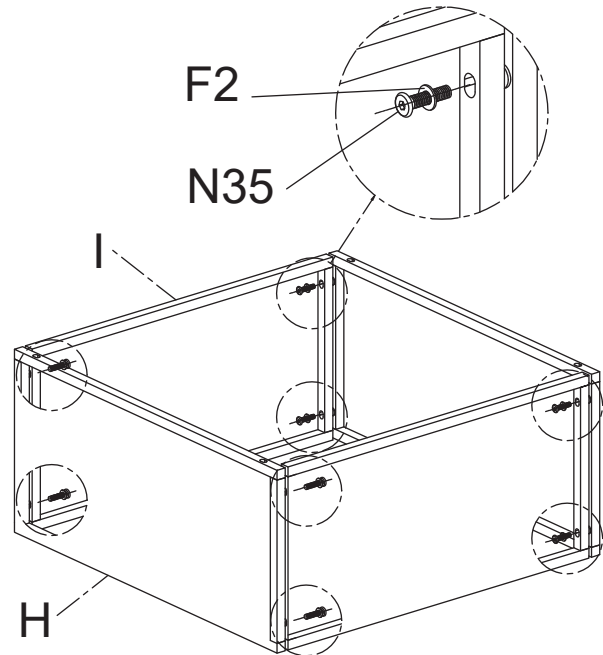

Step Two

Loosely attach the Footstool Top Panel (J) to the above parts using Washers (F2) and Bolts (N35).

Only tighten the bolts when all bolts and washers are in place and turn freely.

Once you are satisfied with the alignment of the components carefully tighten all bolts using Allen Key (AK).

Do not over-tighten.

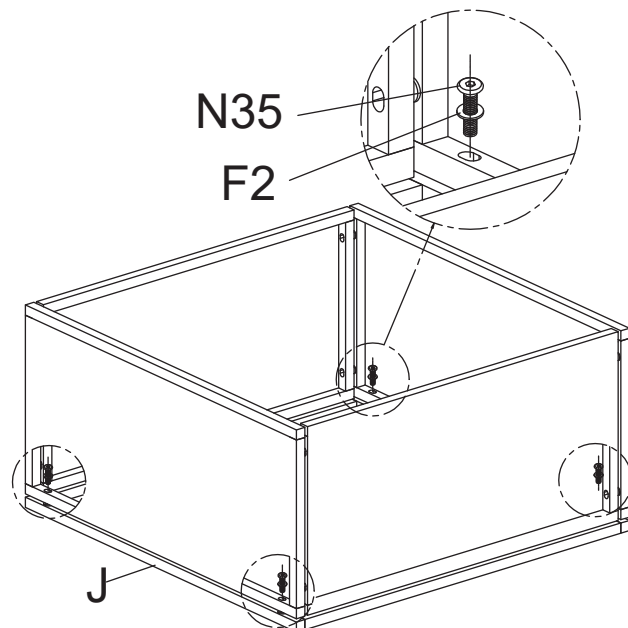

Armchair and Footstool for Berlin 6PCS Corner Lounging Sofa Set Assembly Instructions

Step Three

With the help of another person, carefully turn over the Footstool frame in the upright position.

Place the Seat Cushion (SC) onto the Footstool Top Panel.

Your Footstool is now ready for use.

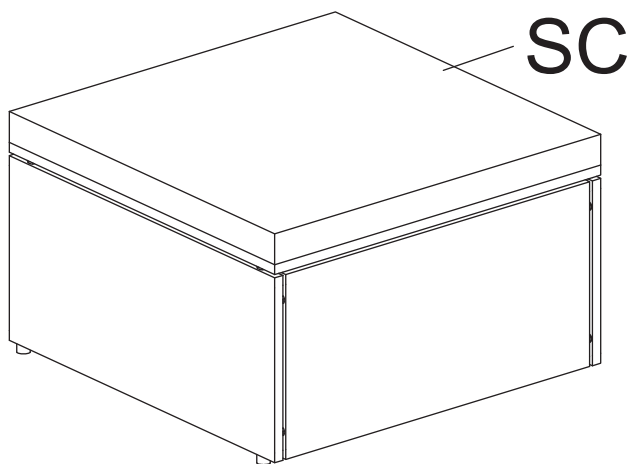
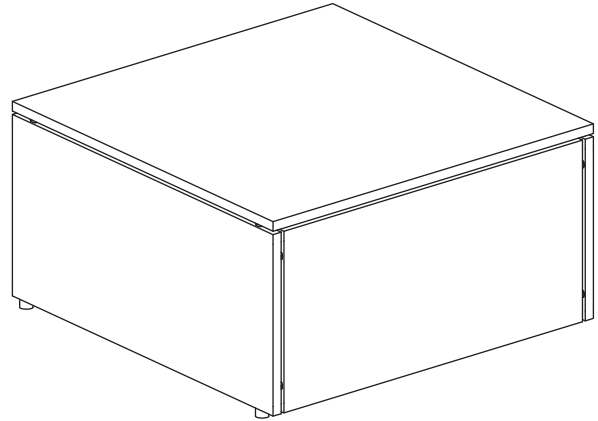

Never tilt the products during use.
Ensure the product is always placed firmly on the ground.

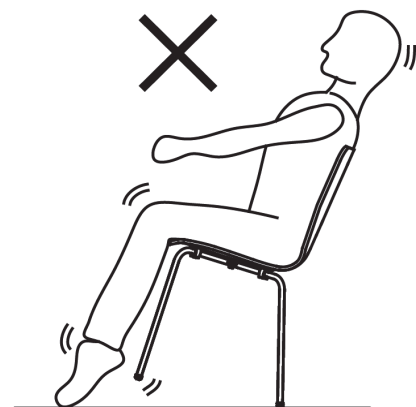

Ensure the product is always placed firmly on the ground.

PLEASE KEEP THESE INSTRUCTIONS FOR FUTURE REFERENCE