

General Instructions

Please retain product label and instructions for future reference

01DTPRMSHDB0808DDOP-V1

DIP TREATED PREMIUM SHIPLAP DUTCH BARN 8X8 DOUBLE DOOR OPENING WINDOW

BEFORE YOU START PLEASE READ INSTRUCTIONS CAREFULLY

- Check the pack and make sure you have all the parts listed.
- When you are ready to start, make sure you have the right tools at hand (not supplied) including a Phillips screwdriver, Stanley knife, Wood saw, Step ladder, Hammer and a Drill with 2mm bit.
- Ensure there is plenty of space and a clean dry area for assembly.

LOCATION FOR YOUR GARDEN BUILDING

A minimum of 60cm should be left around the perimeter of your garden building to allow access for maintenance, annual treatment and to allow air flow around the building.

Where possible you should avoid placing your garden building underneath large trees to prevent the tree causing damage to the building.

TIMBER

As with all natural materials, timber can be affected during various weather conditions. For the duration of heavy or extended periods of rain, swelling of the wood panels may occur. Warping of the wood may also occur during excessive dry spells due to an interior moisture loss. Unfortunately, these processes cannot be avoided but can be helped. It is suggested that the outdoor building is sprayed with water during extended periods of warm sunshine and sheltered as much as possible during rain or snow.

Once your garden building has been installed it will need to be treated as soon as possible and annually to prevent the timber from deteriorating and to waterproof it. This is required to maintain the anti-rot guarantee.

Dip Treated buildings - Require a preservative treatment to protect against rot and decay and a waterproof treatment to prevent water ingress

Pressure Treated buildings - Require a waterproof treatment to prevent water ingress

Log Cabins - Are supplied untreated and require a preservative and waterproofing treatment.

BUILDING A BASE

When thinking about where the building and base is going to be constructed: Ensure that there will be access to all sides for maintenance work and annual treatment.

Ensure the base is level and is built on firm ground, to prevent distortion. Refer to diagrams for the base dimensions, The base should be slightly smaller than the external measurement of the building, i.e. The cladding should overlap the base, creating a run off for water. It is also recommended that the floor be at least 25mm above the surrounding ground level to avoid flooding.

TYPES OF BASE

- Concrete 75mm laid on top of 75mm hard-core.
- Slabs laid on 50mm of sharp sand.

Whilst all products manufactured are made to the highest standards of Safety and in the case of childrens products independently tested to EN71 level, we cannot accept responsibility for your safety whilst erecting or using this product.



x2

All buildings should be erected by two adults



Winter = High Moisture = Expansion
Summer = Low Moisture = Contraction



2mm Drill bit

For ease of assembly, you **MUST** pilot drill all screw holes and ensure all screw heads are countersunk.



CAUTION

Every effort has been made during the manufacturing process to eliminate the prospect of splinters on rough surfaces of the timber. You are strongly advised to wear gloves when working with or handling rough sawn timber.



For ease of assembly, you will need a tape measure to check dimensions of components.

Screws & Nails



Measure overall length

Bolts

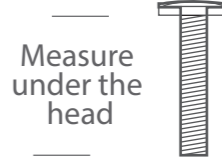

Measure under the head

To identify the fixings required for each step use a measuring tape.

****Protim Aquatan T5 (621)****

Your building has been dip treated with **Aquatan**.

Aquatan is a water-based concentrate which is diluted with water, the building as been treated by the correct application of Aquatan solution and then allowed to dry.

Aquatan is a decorative finish to colour the wood, which is applied industrially to timber fence panels and garden buildings.

Aquatan undiluted contains: boric acid, sodium hydroxide 32% solution, aqueous mixture of sodium dioctyl sulphosuccinat and alcohols: 2, 4, 6-trichlorophenol.



REGISTER FOR YOUR
ANTI-ROT
GUARANTEE TODAY

PLEASE SCAN HERE:



For assistance please contact customer care on: 01636 821215

Mercia Garden Products Limited,

Sutton On Trent,

Newark,

Nottinghamshire,

NG23 6QN

www.merciagardenproducts.co.uk

mercia
GARDEN PRODUCTS
LTD

01DTPRMSHDB0808DDOP-V1

Please retain product label and instructions for future reference

Overall Dimensions:

Width = 2539mm
Depth = 2408mm
Height = 2626mm

Base Dimensions:

Width = 2350mm
Depth = 2350mm

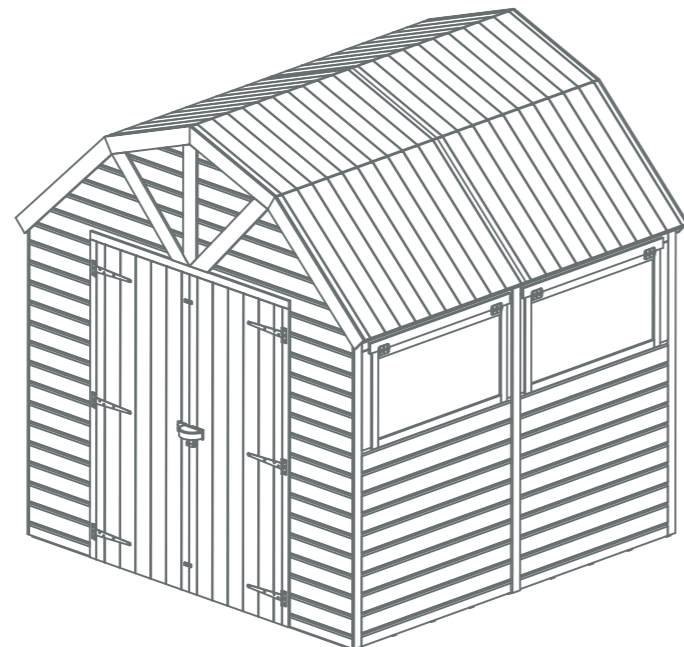

Before assembly
please make sure you have a
suitable base ready to erect your
building



1

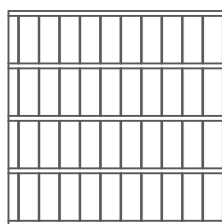

Floor QTY 4

AI-S21MBF1175X1175-V1

2

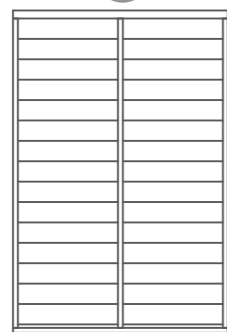

Back Panel

Width 1180mm QTY 2
AI-S21SHPP1180X1796-V1

3

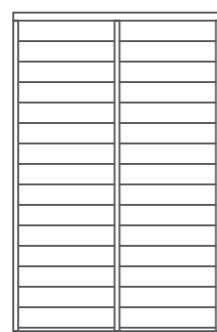

Side Panel

Width 1417mm QTY 2
AI-S21SHPP1136X1814-V1

4

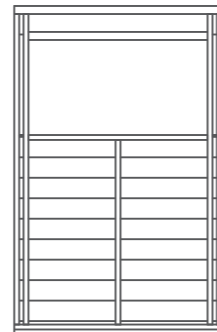

Window Panel QTY 2

AI-O1S21SH1LFW1136X1814-V1

5



Door QTY 2

AI-S21FBMBZBD676X1770-V1

6



Front Panel QTY 2

AI-S21SHPPTOV512X1761-V1

7

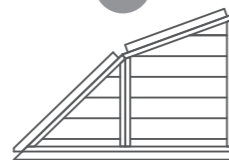

Gable Top Right QTY 2

AI-S22HDBGTR1180X817-V1

8



Gable Top Left QTY 2

AI-S22HDBGTL1180X817-V1

9



Lower Truss QTY 2

AI-S22HDBTF800X88-V1

10

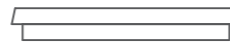

Upper Truss QTY 2

AI-S22HDBTF629X88-V1

11



Top Roof QTY 4

AI-S21MBDBR1192X654-V1

12

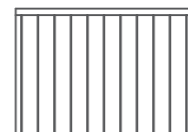

Bottom Roof QTY 4

AI-S21MBDBR1192X898-V1

13

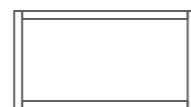

Window QTY 2

AI-FW1000X540-V1

14



Floor Blocks

27x44x400mm QTY 8
F2744-400MM

15



Door Cloaking Strip 27x44x1670mm QTY 1

F2744-1670MM

16



Door Strip 12x45x1449mm QTY 1

S1245-1449MM

17



Door Strip 12x45x1772mm QTY 2

S1245-1772MM

18



Window Strip 12x56x1037mm QTY 2

S1256-1037MM

19



Cover Trims 12x56x1790mm QTY 7

S1256-1790MM

20



Gable Cover Trims

12x56x710mm QTY 1

S1256-710MM

21



Top Door Framing

44x44x280mm QTY 2

F4444-280MM

22



Top Door Framing 44x44x1800mm QTY 1

F4444-1800MM

23



Bottom Door Framing 27x44x1336mm QTY 1

F2744-1336MM

24



Barge Board 12x95x678mm QTY 1

S1295-G-678MM

25



Fascia 12x95x900mm QTY 4

S1295-G-900MM

26



Barge Board 12x95x734mm QTY 2

S1295-G-734MM

27



Fascia 12x95x662mm QTY 4

S1295-G-662MM

28



Gable Strip 12x121x2090mm QTY 2

WB-2090MM

29



Truss Brace 27x44x1640mm QTY 2

F2744-G-1680MM

30



Door Blocks

27x44x150mm QTY 2

F2744-150MM

31

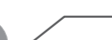

Truss Blocks

27x44x100mm QTY 2

F2744-G-120MM

32



Casement Stay QTY 2

PI-07-0007

33

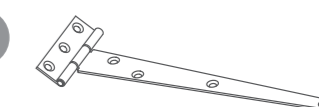

T Hinge QTY 6

PI-07-0021

34

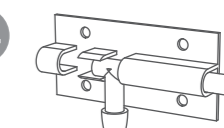

Tower Bolt QTY 2

PI-07-0030

35



Turn Button QTY 2

PI-07-0034

36

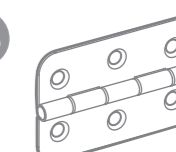

Butt Hinge QTY 4

PI-07-0066

37

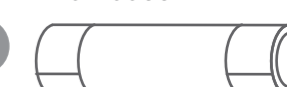

Felt QTY 2

PI-01-0003

38

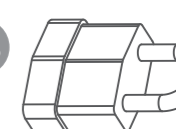

Weatherproof Lock QTY 1

PI-07-0222

39



Hasp and Staple Lock QTY 1

PI-07-0221

40

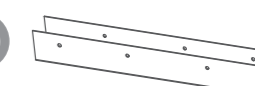

U Channel QTY 4

PI-07-0013

41



Joining Plates QTY 6

PI-07-0220

Nail Bag

There may be extra screws present in the nail bag

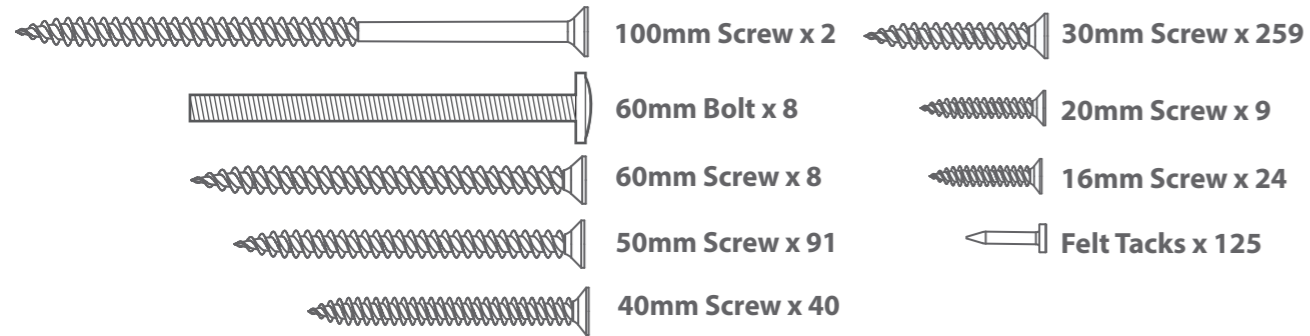

Pre Assembly

Before assembling remove the transportation blocks from the bottom of each panel.

Take care removing the blocks as to not damage the panels. Tap with a flat headed screwdriver and hammer.

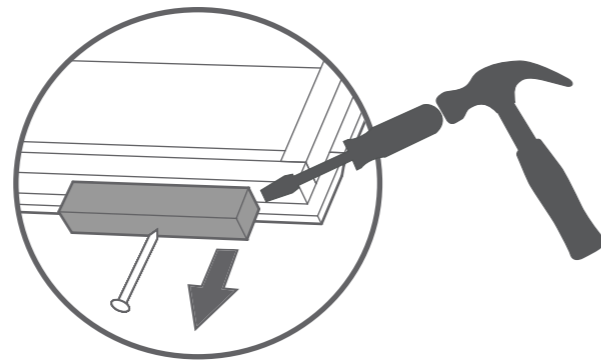

Dispose of the blocks once removed.

Step 1

Parts Needed- No.1 QTY 4

Place the floor panels (No.1) onto a firm and level base. Ensure the base has suitable drainage, free from areas where standing water can collect.

Secure the floors together using 8x50mm screws through the floor bearers in an alternating pattern.

Repeat the step to create two floor assemblies.

16x50mm Screws

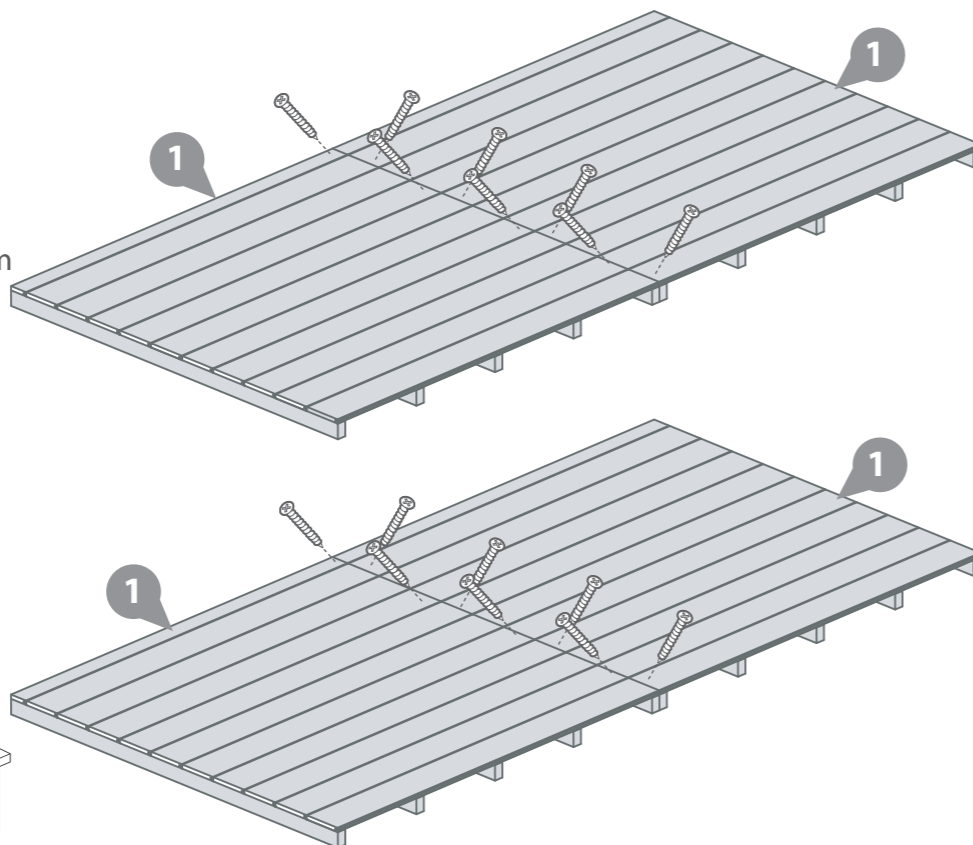
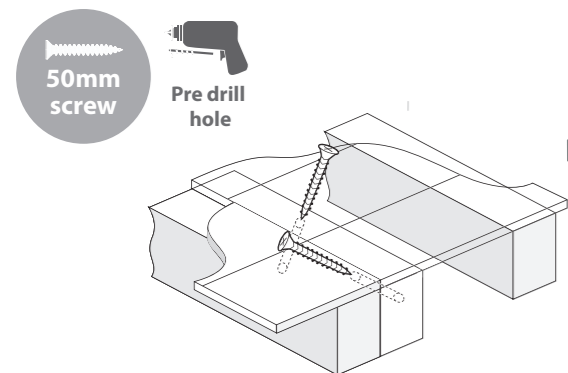

Step 2

Parts Needed- No.14 QTY 8

Locate the Floor Blocks (No.14) between the floor framing, ensuring they are spaced equally.

Secure to the floor using 2x40mm screws per block, going through the floor cladding and into the floor blocks below.

16x40mm Screws

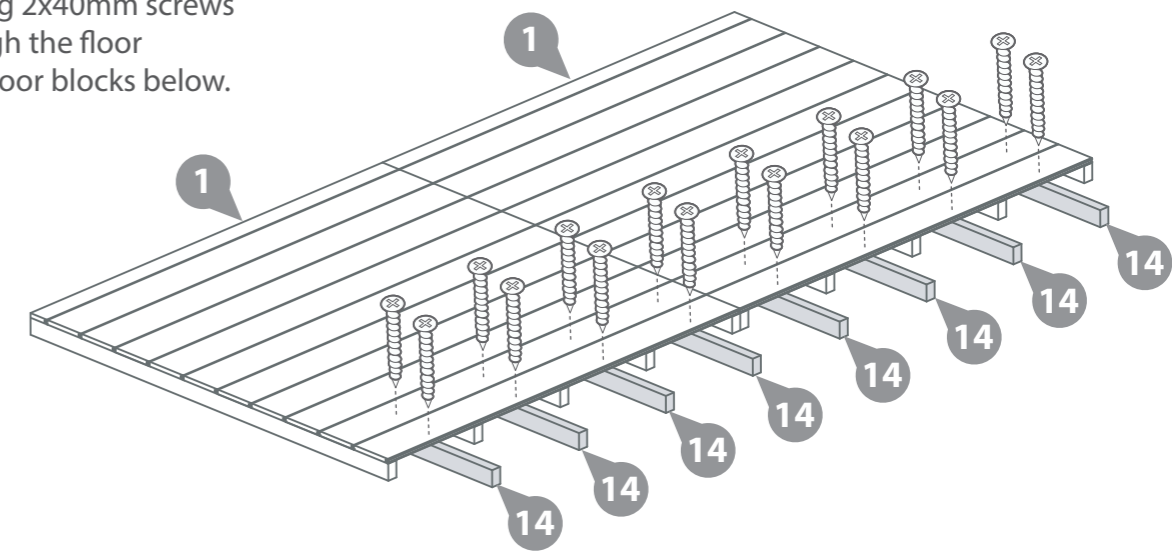

Step 3

Locate the second floor assembly along side the first floor assembly.

Secure to the floor using 2x40mm screws per block, going through the floor cladding and into the floor blocks below.

16x40mm Screws

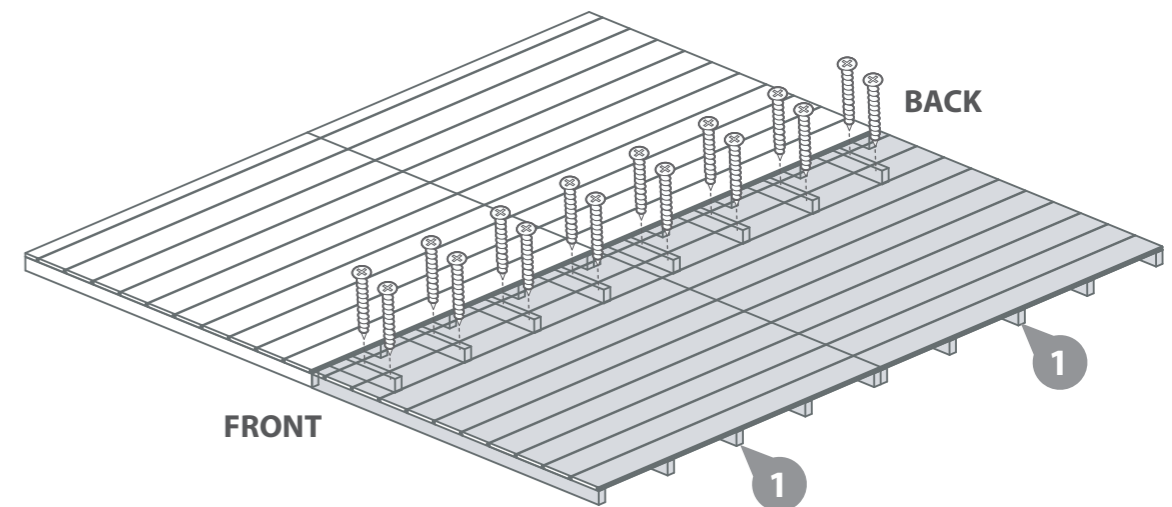

Step 4

Parts Needed- No.2 QTY 1
- No.3, (or 4) QTY 1

****Please note: These side panels are interchangeable. Decide which layout works best for you before assembly.****

Locate the Back Panel (No.2) and the Side panel (No.3) (or Window Panel) onto the floor, secure the panels at the corner using 3x50mm screws.

Do not secure the building to the floor until the roof is fitted.

Position the panels so there is equal spacing.

****Please note: The Side Panels are slightly higher than the back panels.****

3x50mm Screws

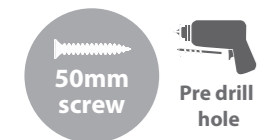

BACK PANEL SIDE PANEL

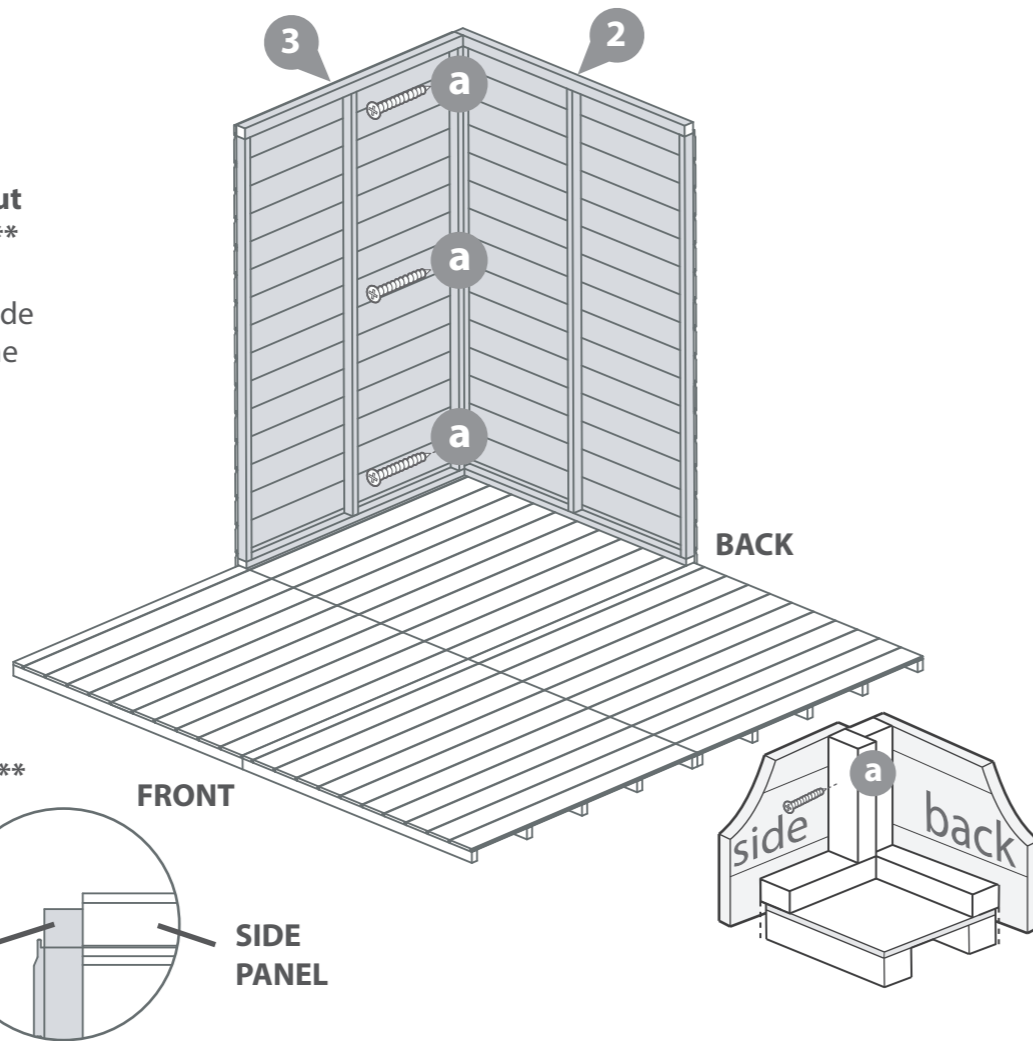

Step 6

Parts Needed- No.4, (or 3) QTY 1

Locate the Window Panel (No.4) (or Side Panel) onto the floor, secure the panels at the corner using 3x50mm screws.

Do not secure the building to the floor until the roof is fitted.

Position the panels so there is equal spacing.

****Please note: The Side Panels are slightly higher than the back panels.****

3x50mm Screws



BACK PANEL SIDE PANEL

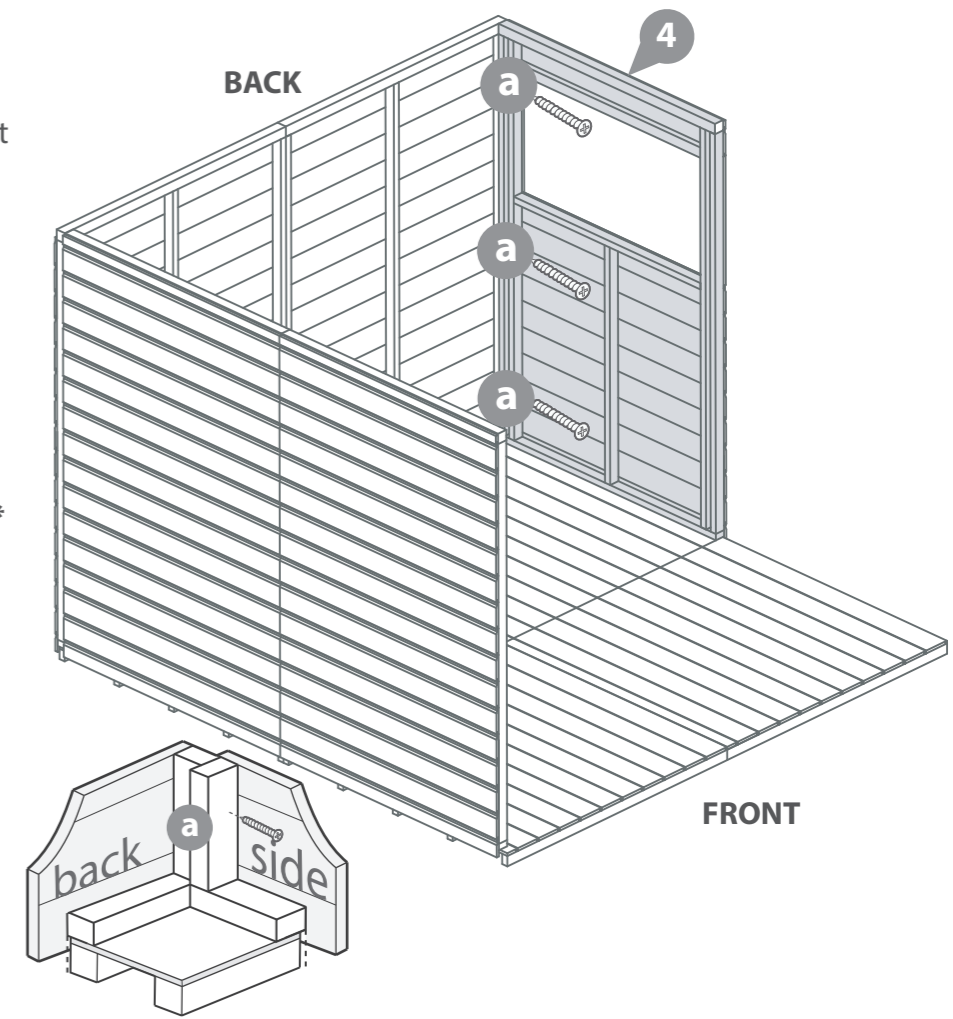

Step 5

Parts Needed- No.2 QTY 1
- No.3, (or 4) QTY 1

Locate the Second Back Panel (No.2) and Side panel (No.3) (or Window Panel) onto the floor, secure the panels at the joins using 3x50mm screws per join in an alternating pattern.

Do not secure the building to the floor until the roof is fitted.

Position the panels so there is equal spacing.

****Please note: The Side Panels are slightly higher than the back panels.****

6x50mm Screws

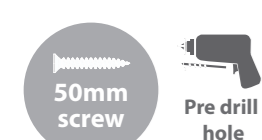

BACK PANEL SIDE PANEL

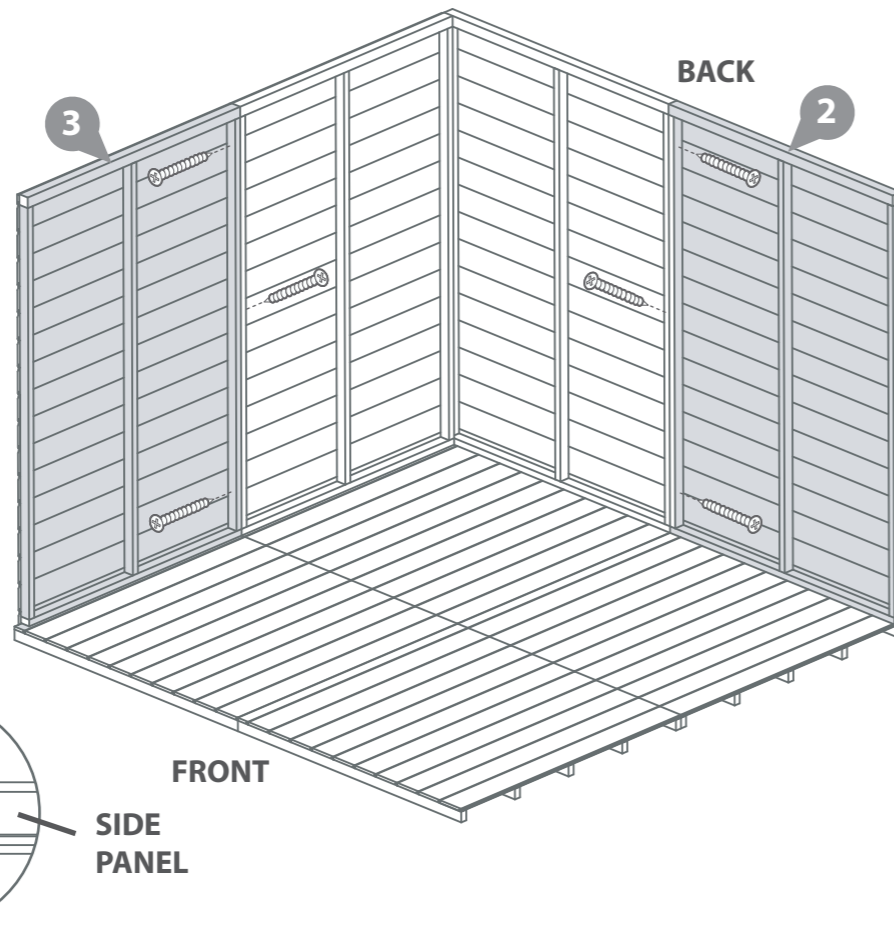

Step 7

Parts Needed- No.4, (or 3) QTY 1

Locate the Second Window Panel (No.4) (or Side Panel) onto the floor, secure the panels at the joins using 3x50mm screws per join in an alternating pattern.

Do not secure the building to the floor until the roof is fitted.

Position the panels so there is equal spacing.

****Please note: The Side Panels are slightly higher than the back panels.****

3x50mm Screws



BACK PANEL SIDE PANEL

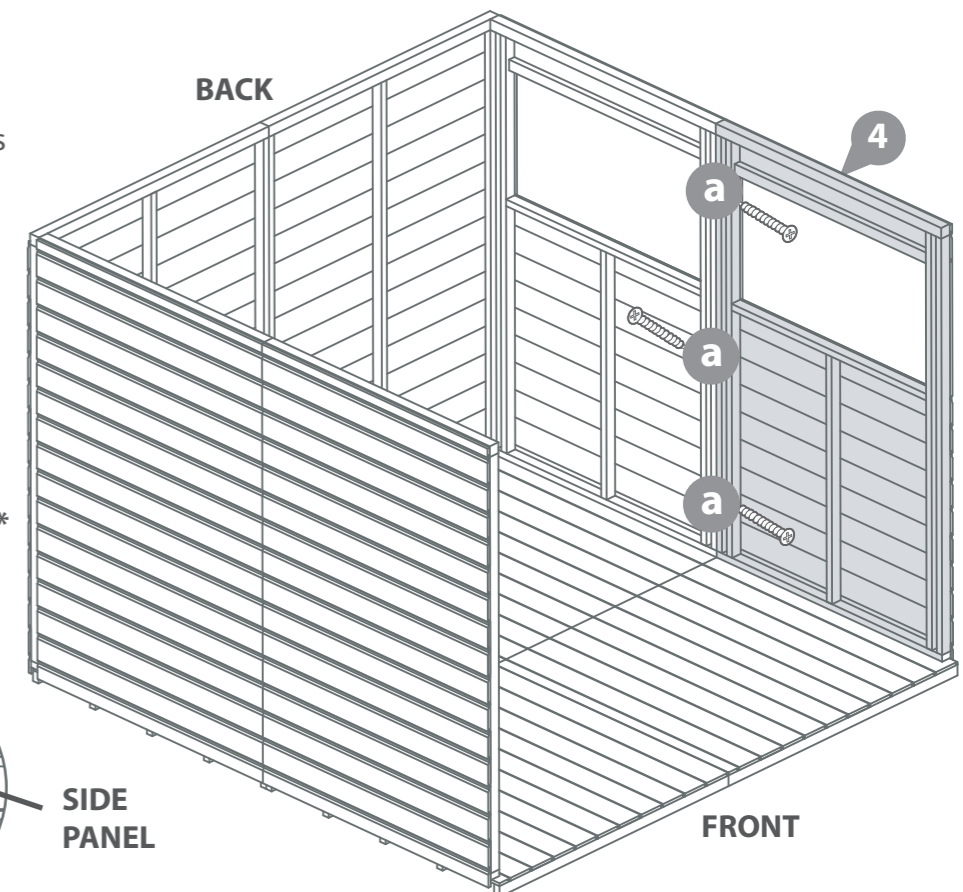

Step 8

Parts Needed- No.6 QTY 2

Locate the Front Panels (No.6) onto the floor, secure the panels at the corners using 3x50mm screws per join.

Do not secure the building to the floor until the roof is fitted.

Position the panels so there is equal spacing.

****Please note: The Front Panels are slightly lower than the side panels.****

6x50mm Screws

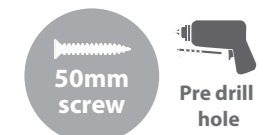

FRONT PANEL SIDE PANEL

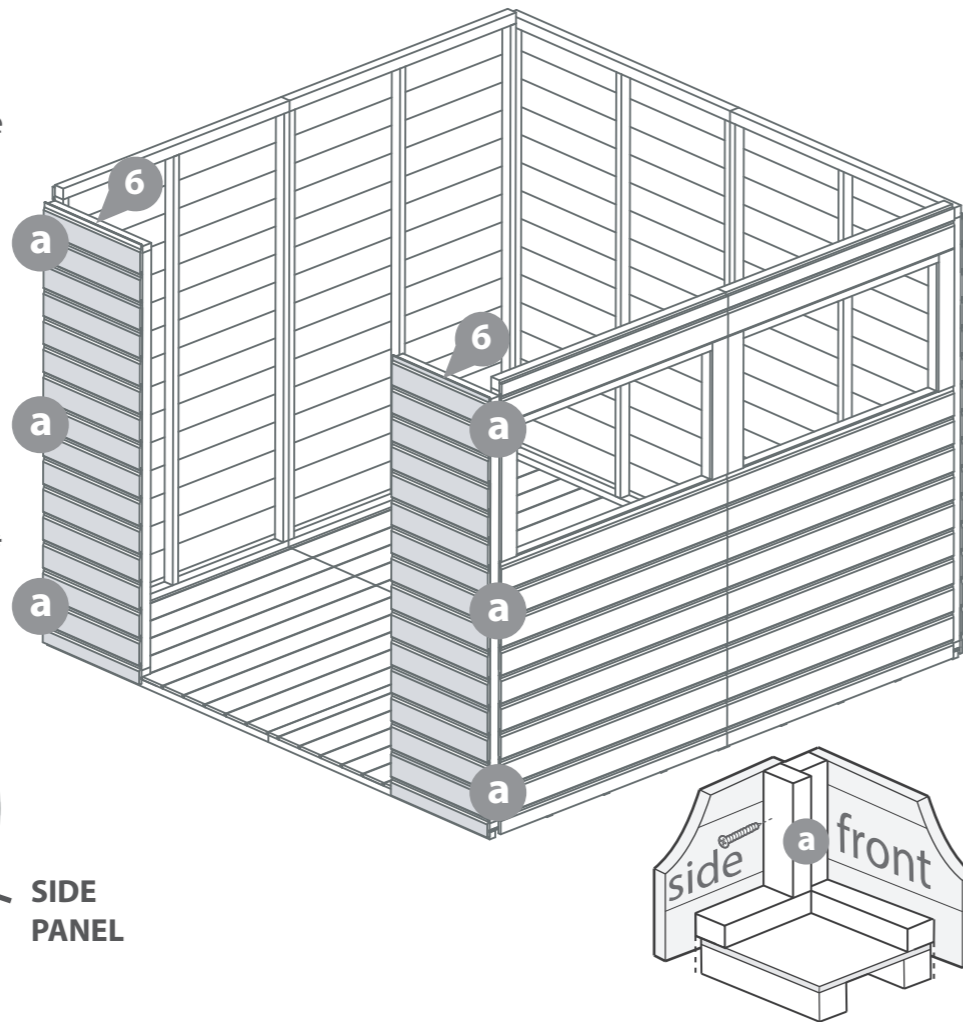

Step 9

Parts Needed- No.21 QTY 2

- No.22 QTY 1

- No.23 QTY 1

Locate the Top Door Framings (No.21 and No.22) onto the top of the front panels, the framing should be really flush to the back edges of the framing within front panels.

Secure the framing using 8x60mm screws, ensuring to go through the top door framing, and into the front panel framing.

Locate the Bottom Door Framing (No.23) between the front panel. Do Not secure the Bottom Door Framing to the floor until the roof is fitted.

****Please note: The Front Panels are slightly lower than the side panels.****

8x60mm Screws

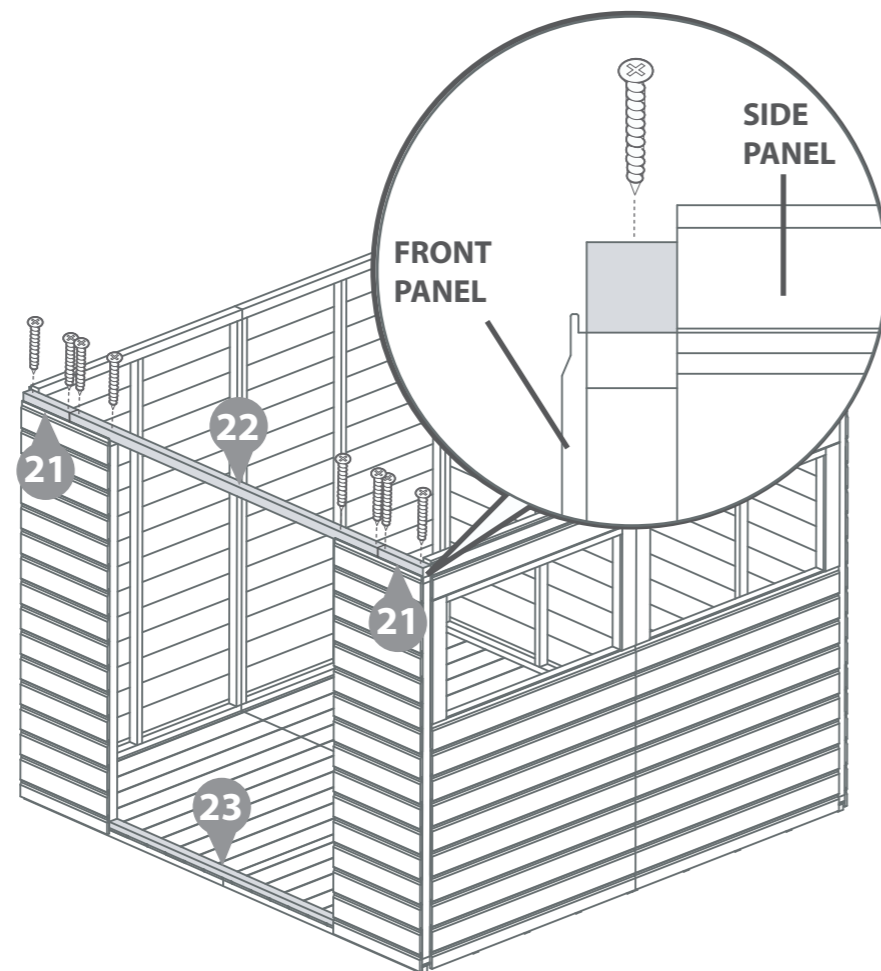

Step 10

Parts Needed- No.7 QTY 2

- No.8 QTY 2

Lay the Gable tops (No.7 and No.8) along side each other, ensure they are flush at the bottom. Secure together using 4x50mm screws in an alternating pattern.

Repeat step to create a second assembly.

8x50mm Screws

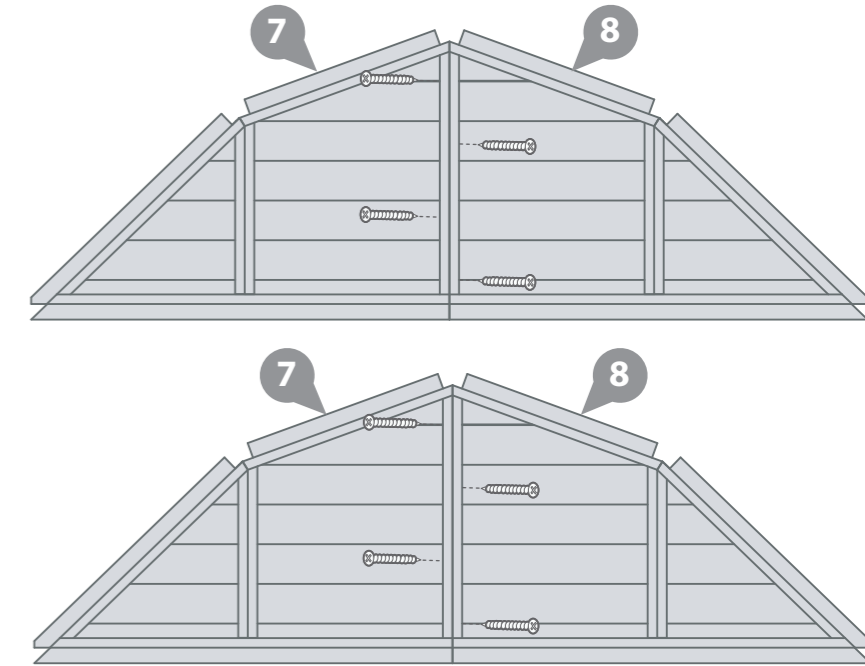

Step 11

Locate the Gable tops (No.7 and No.8) onto the top of the front and back panels. Slot the groove of the boarding within the Gable Tops on to the tongues within the plain panels below. Secure the gable tops from above using 6x50mm screws per gable top.

Ensure the gable tops are flush with the ends of the panels as shown in the diagram.

Do not secure the building to the floor until the roof is fitted.

12x50mm Screws

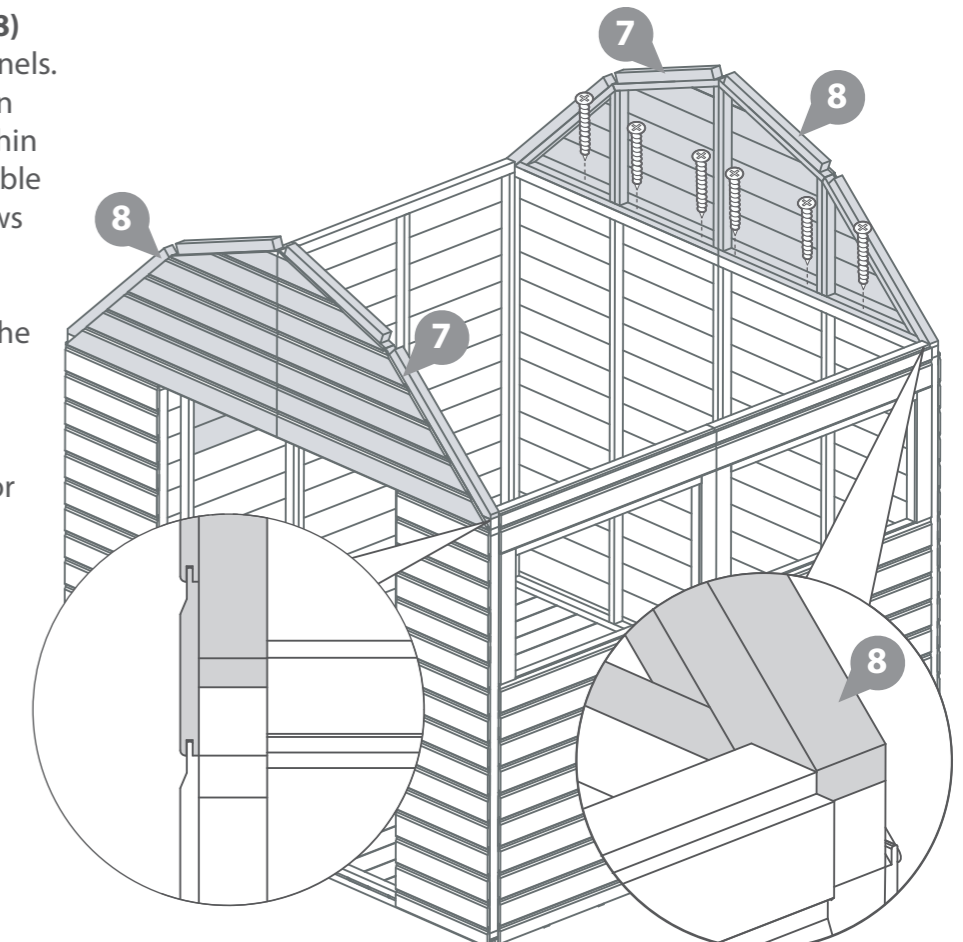
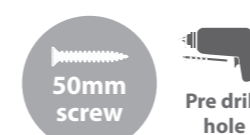

Step 12

Parts Needed- No.28 QTY 2

Locate the Gable Strips (No.28) onto the join of the gable tops and front/back panels, secure the gable strips using 4x30mm screws in an alternating pattern. Do not fix into the gap between the panels.

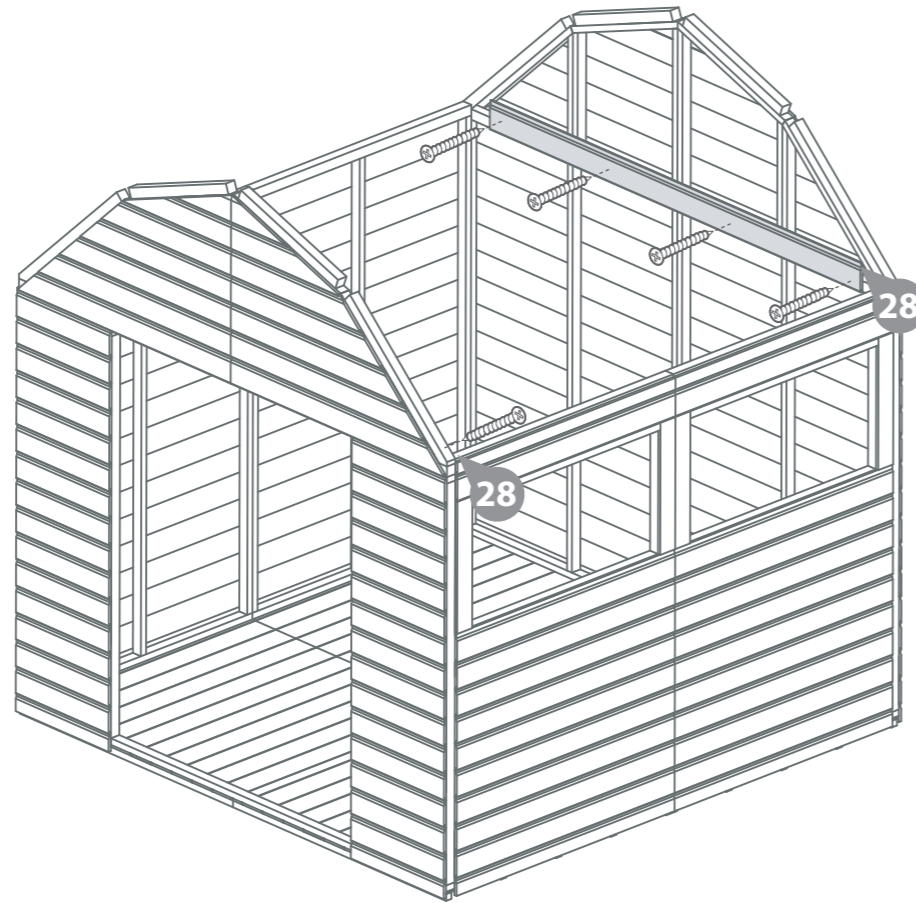

8x30mm Screws

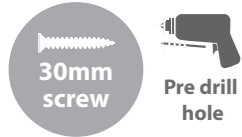

Step 13

Parts Needed- No.9 QTY 2

- No.10 QTY 2
- No.29 QTY 2
- No.41 QTY 6

a Place all of the required parts together on the floor in the correct layout as shown in the illustration. Secure the Joining plates (No.41) to both sides of the truss along the framing joints with 5x30mm screws per plate, ensuring the screws are staggered to avoid collision.

b Secure the Truss Brace (No.29) to both sides of the Lower Trusses, making sure to stagger the 4x40mm screws at each end. The truss brace should finish flush with the edge of the lower truss.

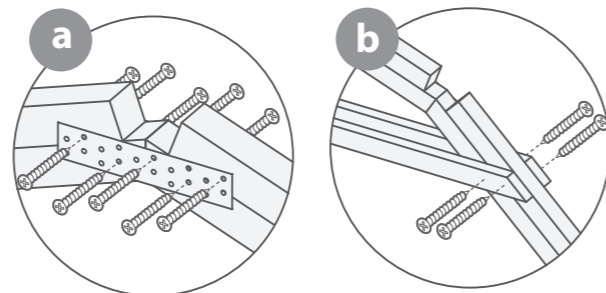
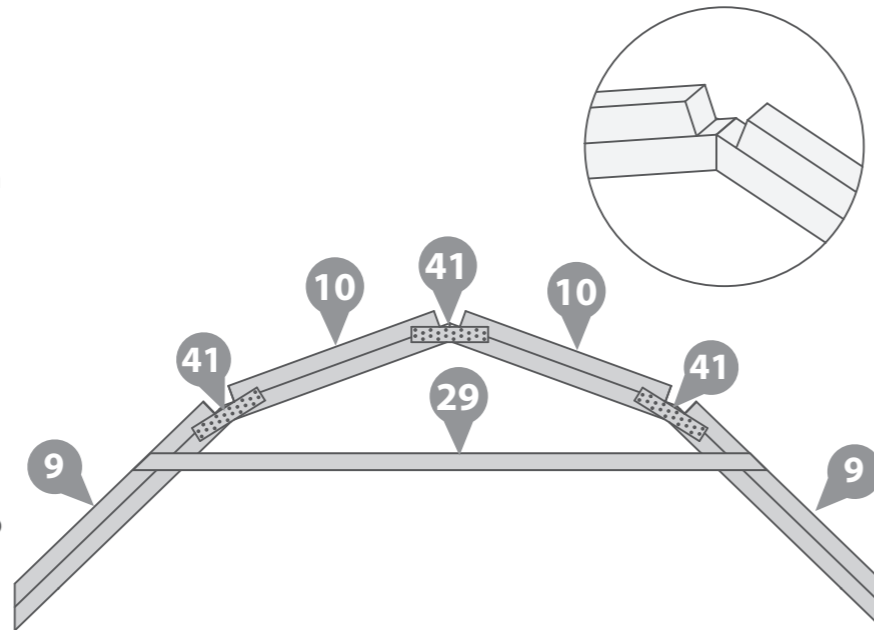

30x30mm Screws
8x40mm Screws

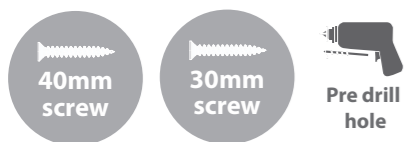

Step 14

Parts Needed- No.31 QTY 2

Measure and mark 42mm from the top corner of the truss.

Place the Truss in position with a 42mm gap from the top corner of the truss to the top of the side panel.

Locate the Truss Blocks (No.31) onto each side of the building, then use the measurement made when together with the truss to determine the height of the Truss blocks and mark the position.

Secure the truss blocks in an alternating pattern using 2x50mm screws per block, ensuring to go through to the panel framing behind. Do not fix into the gap between the panels.

Fix the truss to the side panels using 1x50mm screw per side making sure that you go into the panel framing behind.

Fix a further 100mm screw to each side from the exterior of the building into the truss on the inside.

6x50mm Screws
2x100mm Screws

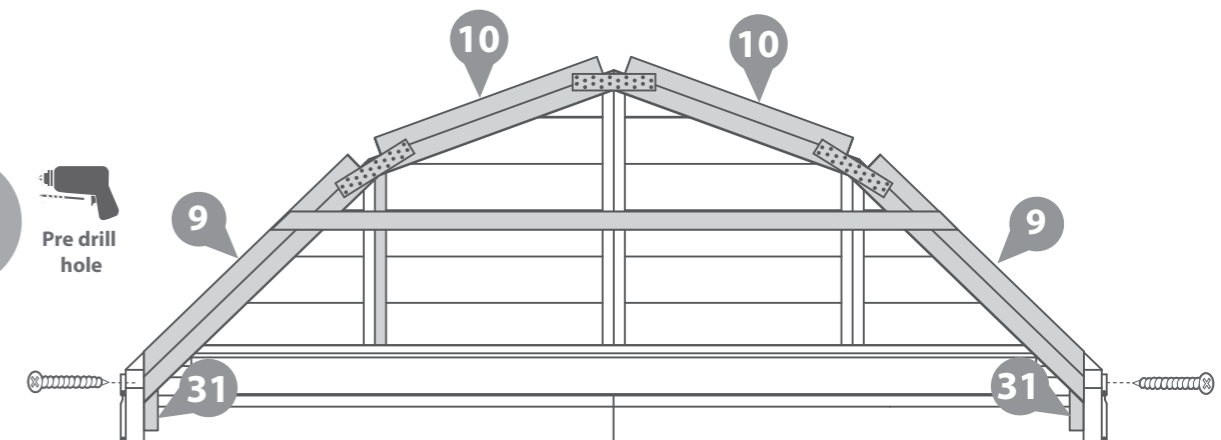
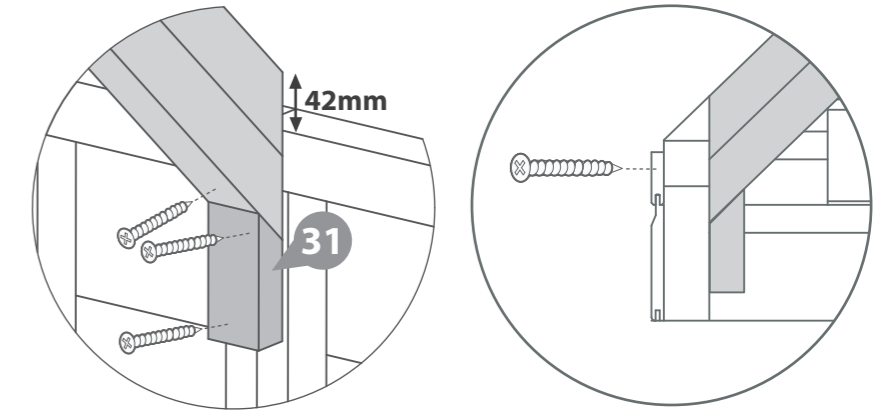

Step 15

Parts Needed- No.12 QTY 4
- No.40 QTY 2

Locate the Bottom roof panels (No.12) and secure the roof panels together using a U channel (No.40) on to the top framing pieces. Ensure the U channel (No.40) is equally spaced over the roof panel framing. Secure the U channels using 10x30mm screws per channel.

Repeat the step to create a second assembly.

20x30mm Screws

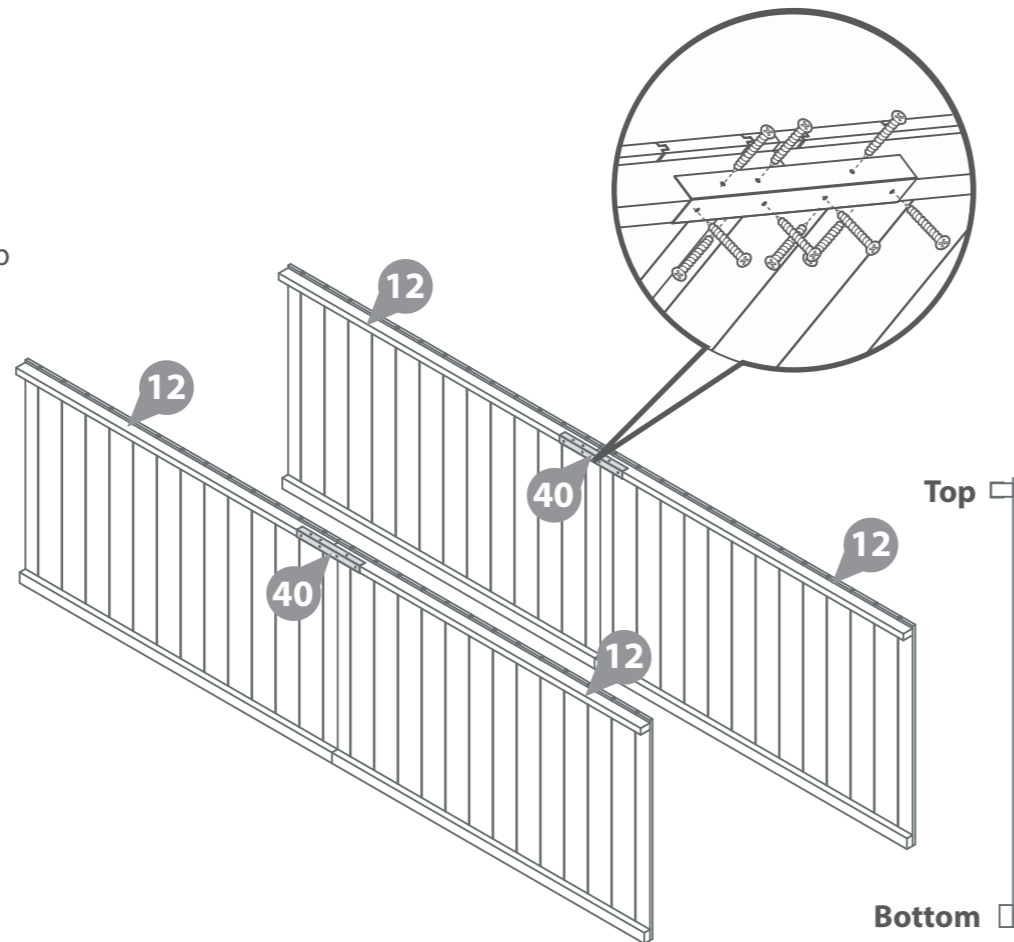
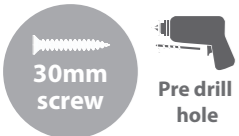

Step 17

Place the Bottom roof panels (No.12) on top of the gables and truss, ensuring they are correctly orientated with the U channel slotted into the roof truss.

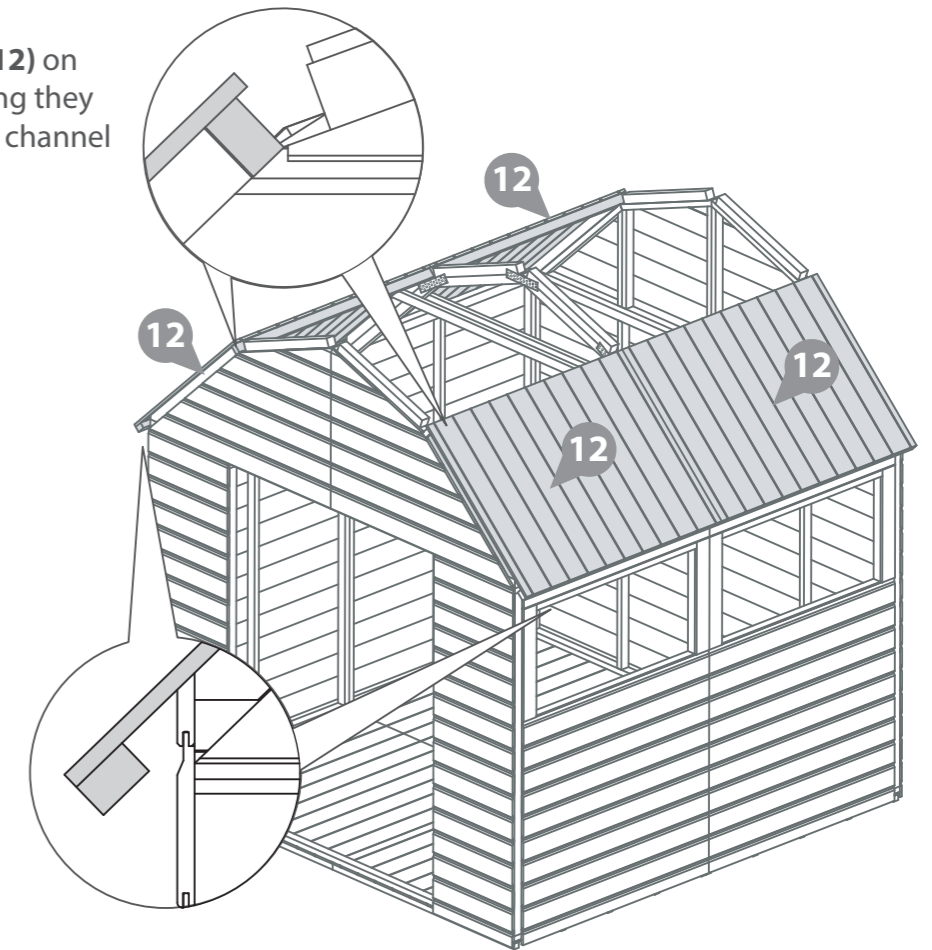

Step 16

Parts Needed- No.11 QTY 4
- No.40 QTY 2

Locate the Top roof panels (No.11) and secure the roof panels together using a U channel (No.40) on to the top framing pieces.

Make sure that the U channel is on the framing within the roof panel where there is a 16mm gap between the top of the framing and the edge of the roof cladding. Ensure the U channel (No.40) is equally spaced over the roof panel framing. Secure the U channels using 10x30mm screws per channel.

Repeat the step to create a second assembly.

20x30mm Screws

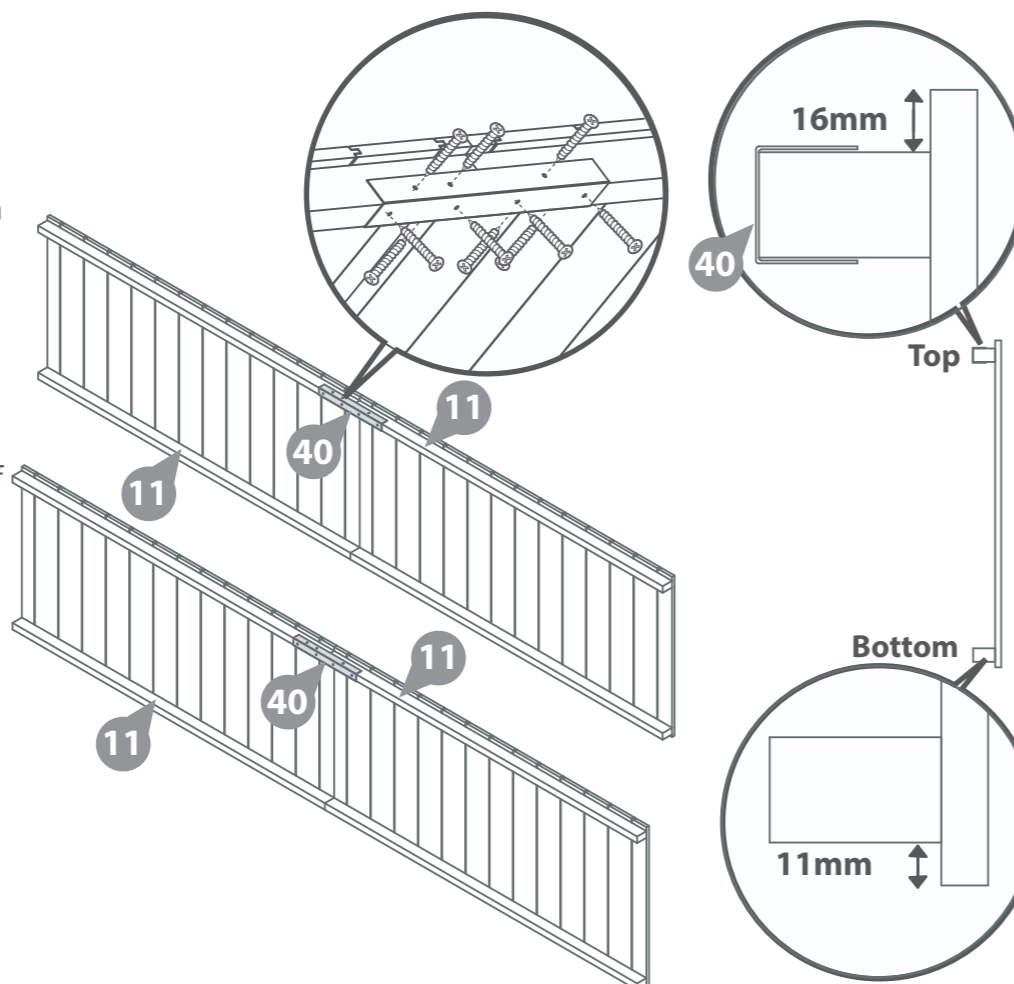
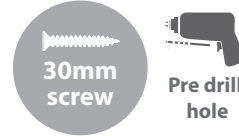

Step 18

Secure the Roofs using 4x30mm screws per roof, ensuring to go through the roof cladding and into the gable top framing and the truss framing below.

Position the panels so there is equal spacing.

****Make sure that the edges of the framing within the roof panels are flush with the outer cladding on the front and back panels.****

Do not secure the building to the floor until the roof is fitted.

16x30mm Screws

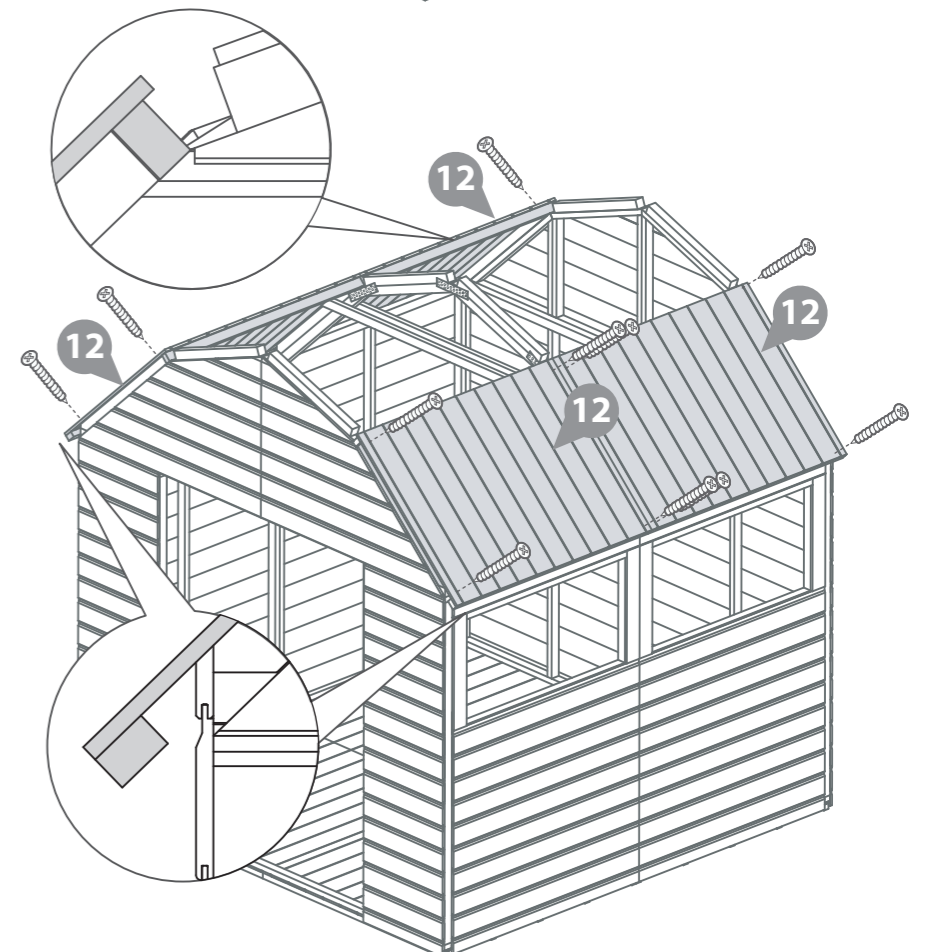

Step 19

Place the Top Roof Panels (**No.11**) on top of the gables and truss, ensuring they are correctly orientated with the U channel slotted into the top of the roof truss.

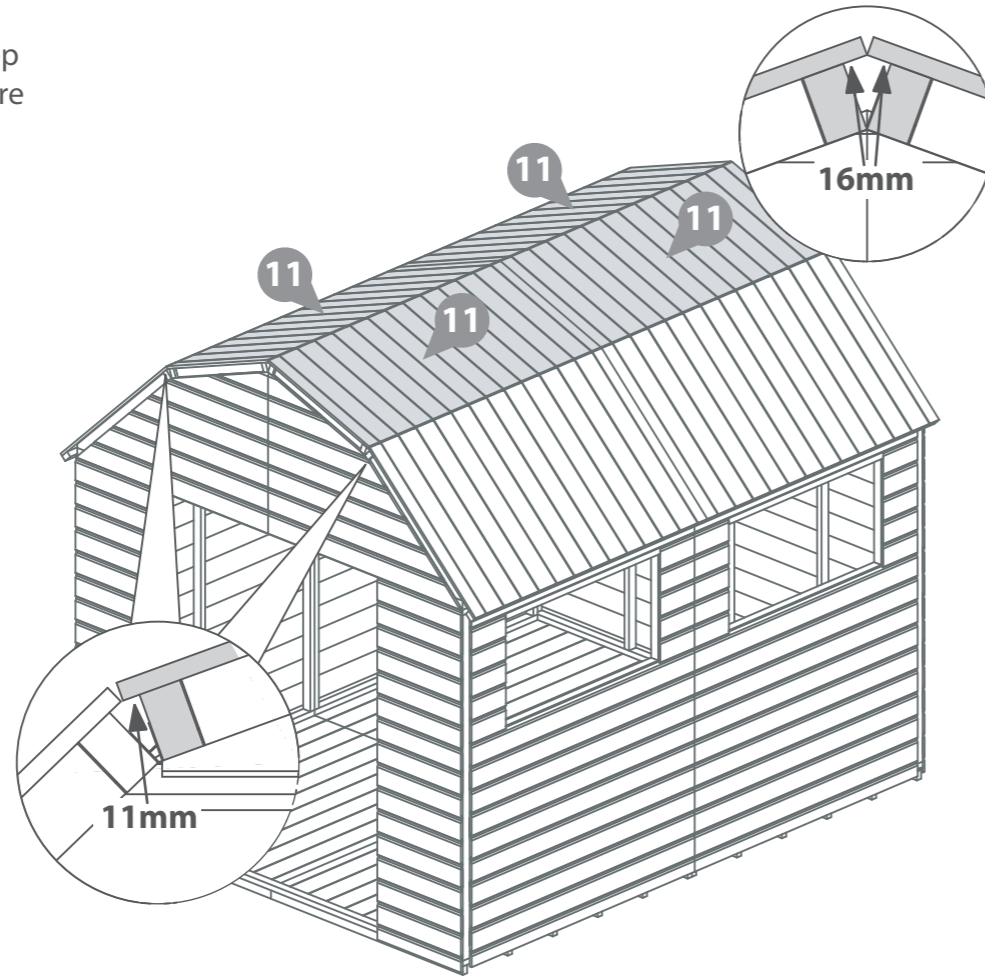

Step 21

Once the roof is fixed, attach the building to the Floor with 50mm screws.

Ensure the screws go through the panel into the Floor framing.

24x50mm Screws

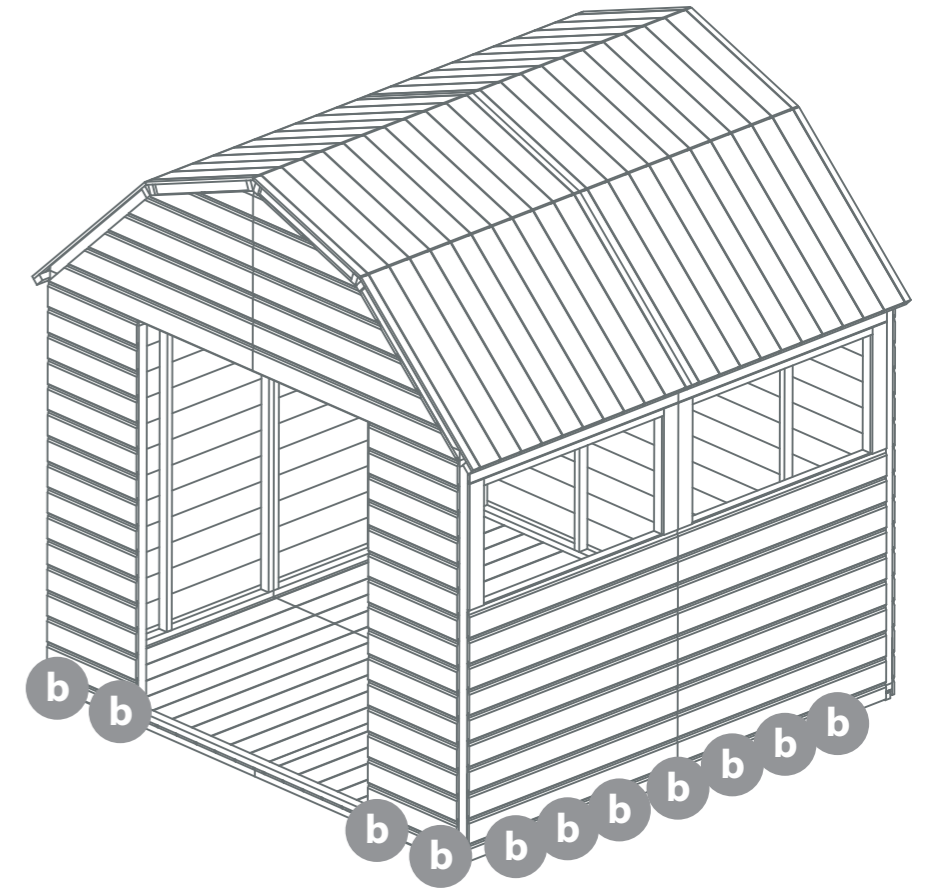
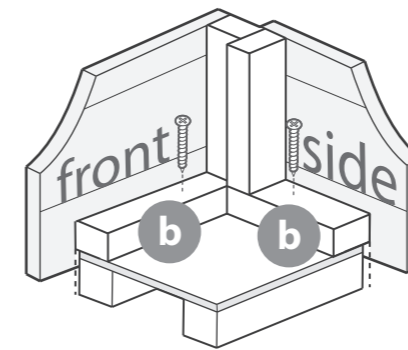

Step 20

Secure the Roofs using 4x30mm screws per roof, ensuring to go through the roof cladding and into the gable top framing and the truss framing below.

Position the panels so there is equal spacing.

****Make sure that the edges of the framing within the roof panels are flush with the outer cladding on the front and back panels.****

Do not secure the building to the floor until the roof is fitted.

16x30mm Screws

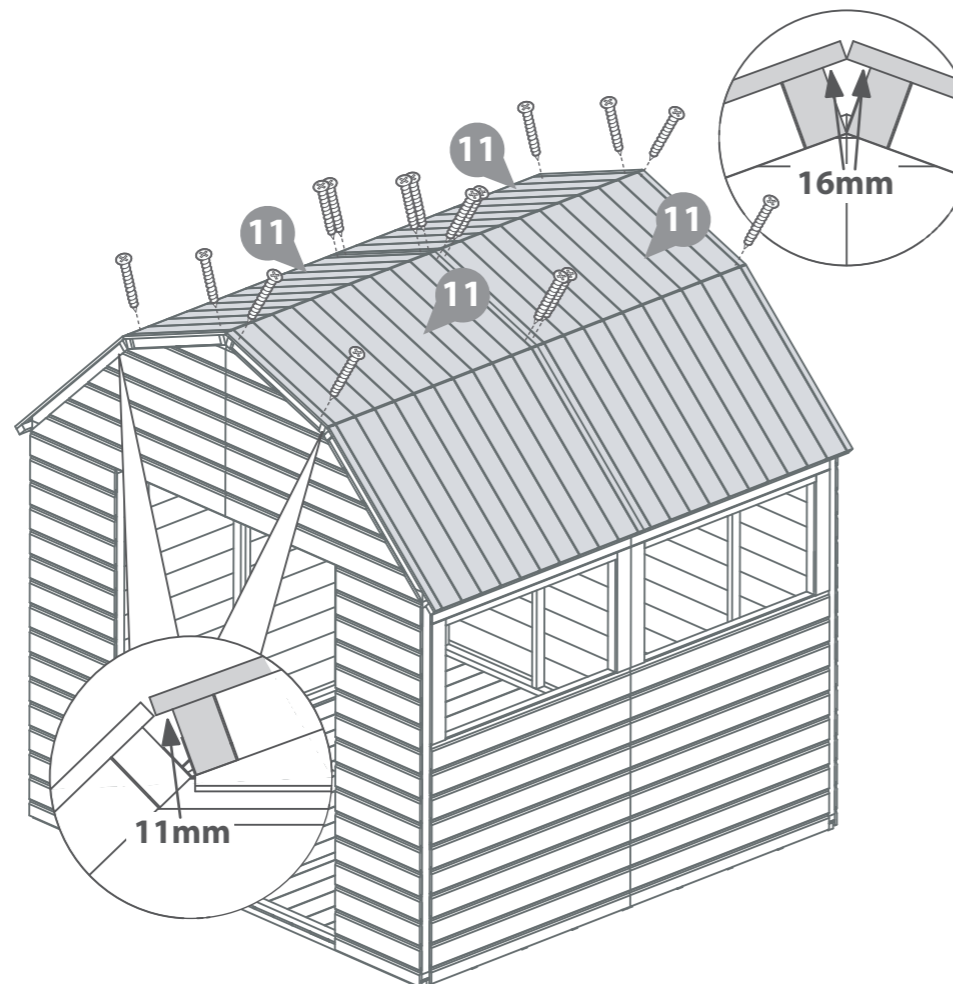
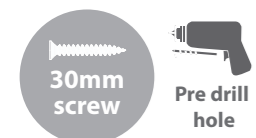

Step 22

Make sure that the Bottom Door Framing (**No.23**) is flush with the framing within the front panels. Fix the Bottom Door Framing to the floor ensuring that you go into the framing below.

4x50mm Screws

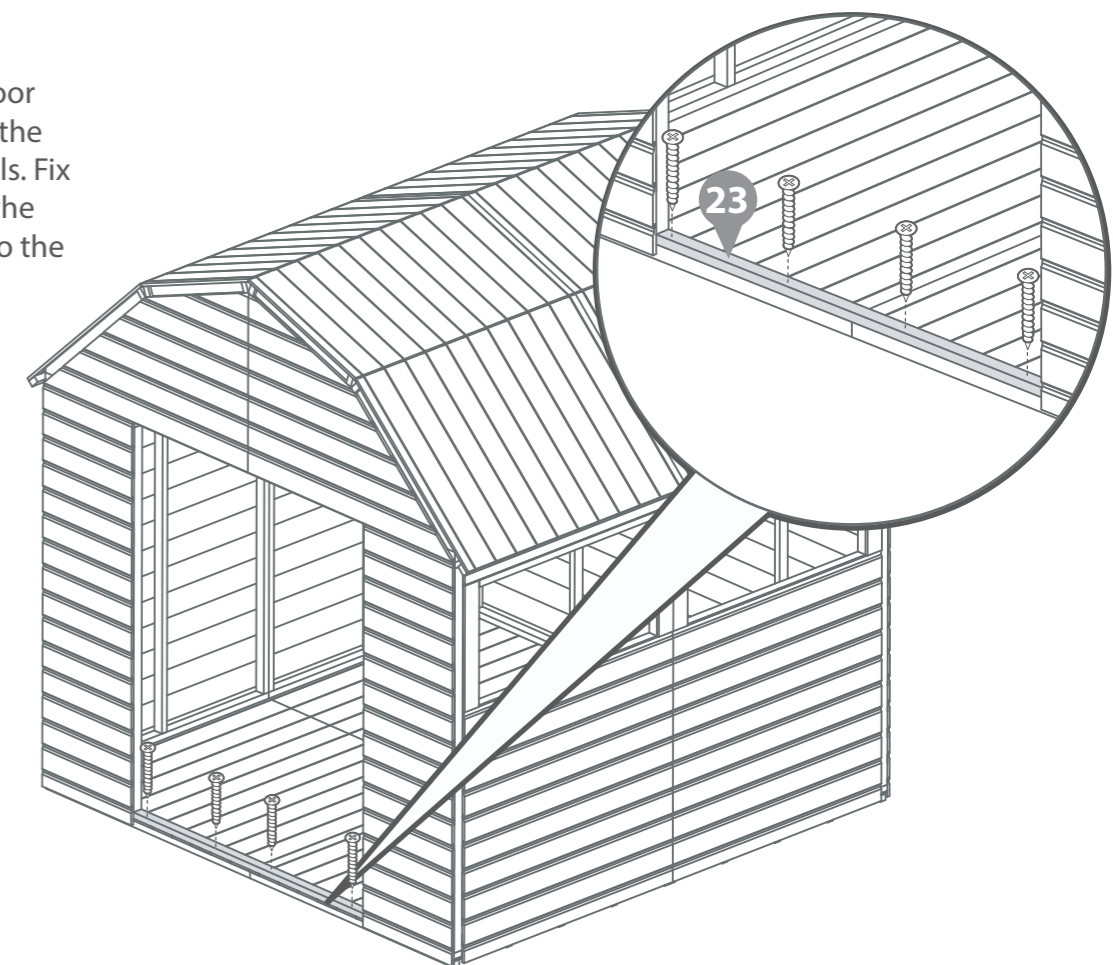

Step 23

Parts Needed- No.16 QTY 1
- No.17 QTY 2

Locate the Door Strips (No.16 & No.17) around the door opening and ensure that they are flush with the framing. There should be a gap between the strips and the door opening as shown.

Secure each strip with 4x30mm screws, going through the strips and into the door panel cladding.

12x30mm Screws

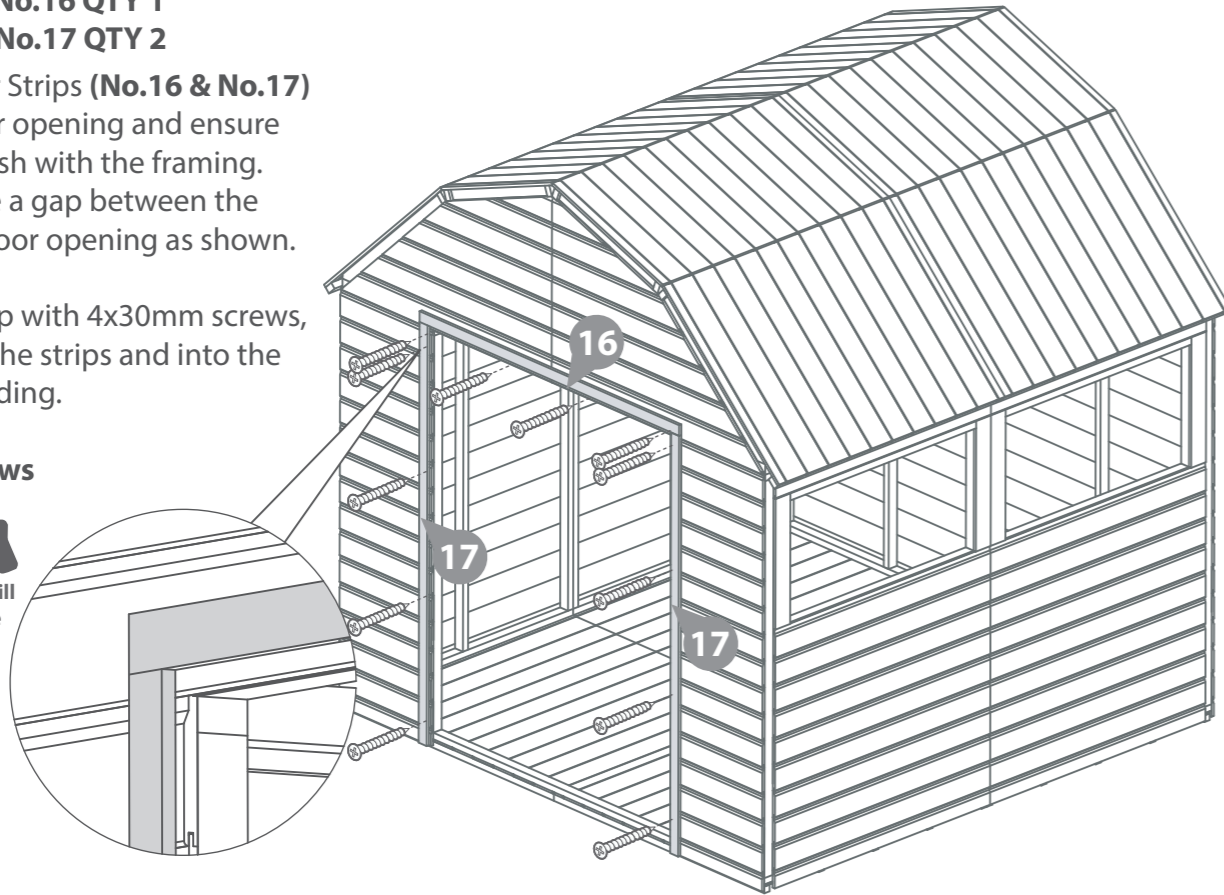
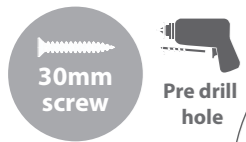

Step 24

Parts Needed- No.5 QTY 2
- No.33 QTY 6

Fix 3 Hinges (No.33) to each Door (No.5) securing with 4x30mm screws per hinge and position as shown.

Fix each Door to the building with 3x30mm screws per hinge. Make sure that the inside view of the door looks like it does on the illustration.

Ensure the doors open and close freely.

42x30mm Screws

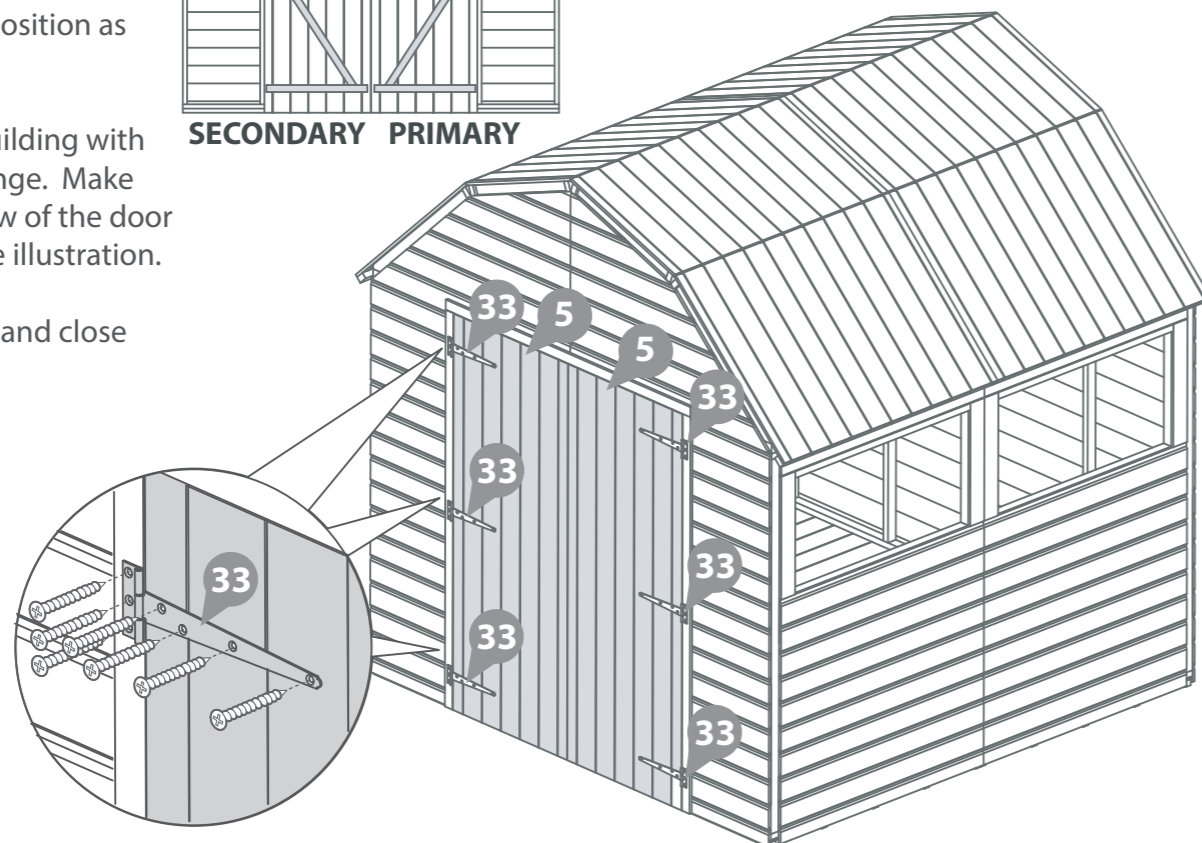
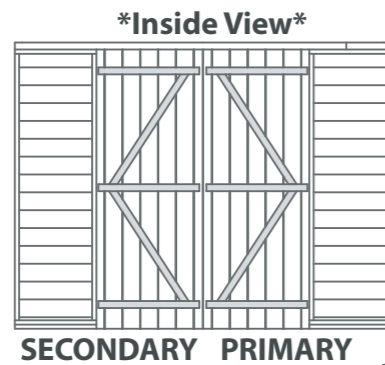
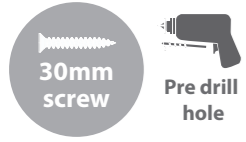

Step 25

Parts Needed- No.15 QTY 1
- No.30 QTY 2

Place the Door Blocks (No.30) onto the top of the door framing and ensure that they are flush with the ends of the framing. Secure using 2x30mm screws per block, going through the front of the door cladding and into the door block.

Locate the Door Cloaking Strip (No.15) between the door framing and ensure that it is equally spaced. Secure to the secondary door using 4x30mm screws, going through the front of the door cladding and into the Door Cloaking Strip.

8x30mm Screws

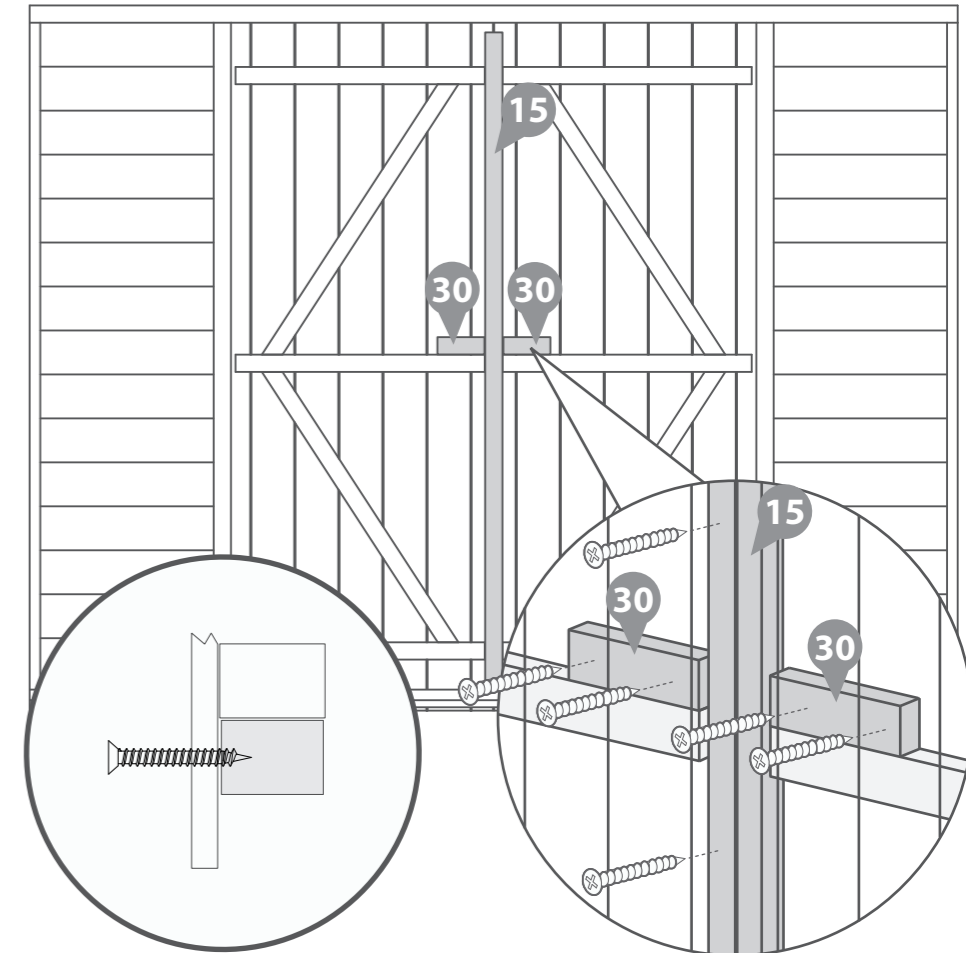
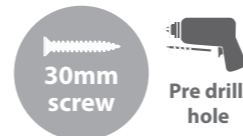

Step 26

Parts Needed- No.34 QTY 2

Align the tower bolts (No.34) onto the door cloaking strip, secure the bolts to the top and bottom using 6x30mm screws per tower bolt.

Mark the position of the bolt & drill a hole above and below for the bolt to catch in to.

12x30mm Screws

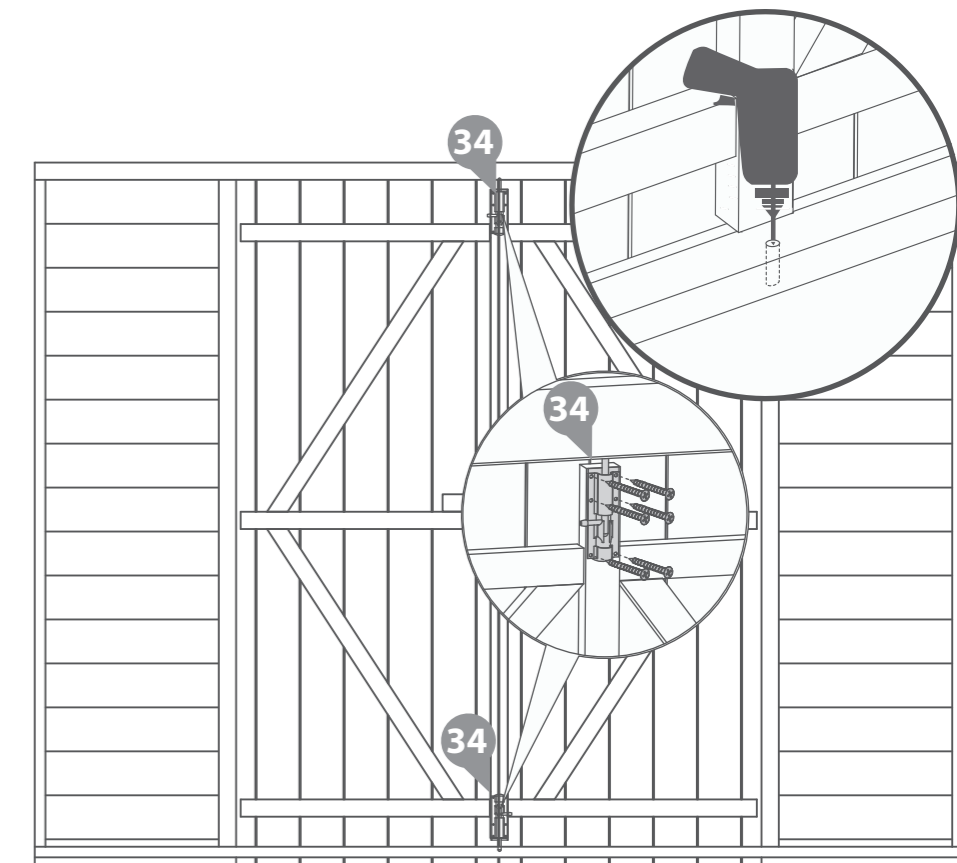
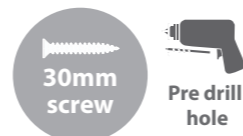

Step 27

Parts Needed- No.39 QTY 2

Align the lock (No.39) to the door, ensuring equal spacing across the doors and in line with the door framing.

Measure and mark the holes of the lock (No.39) and drill through the boards and through the framing and door blocks.

Fix the lock onto the door using 8x60mm Carriage Bolts and Nuts.

8x60mm Carriage Bolts

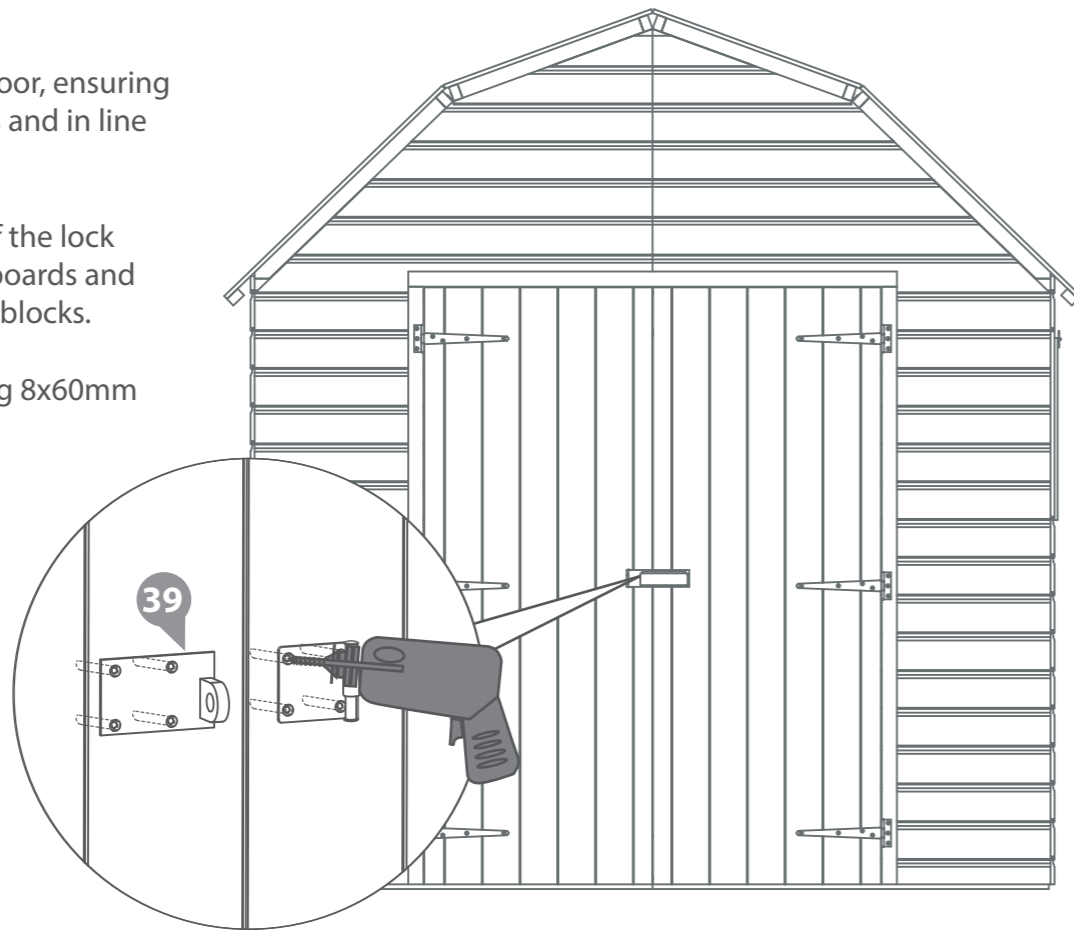
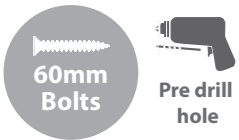

Step 28

Parts Needed- No.35 QTY 2

Attach the turn buttons (No.35) to the secondary door at the top and bottom using 1x30mm screw per turn button.

2x30mm Screws

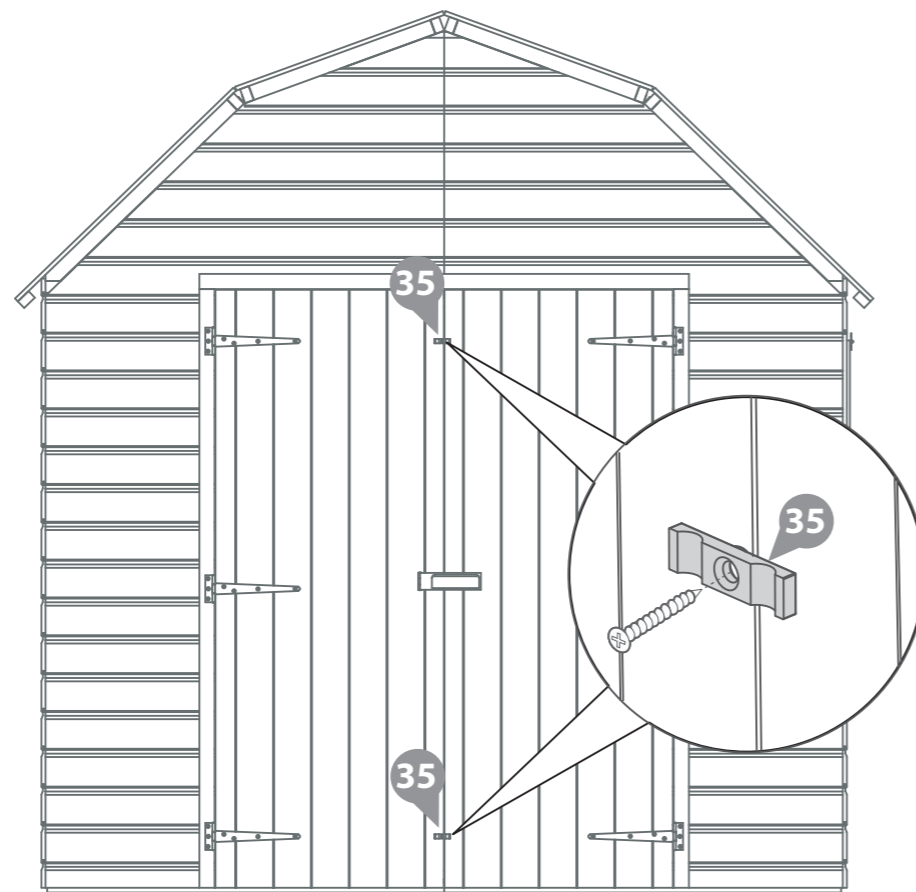
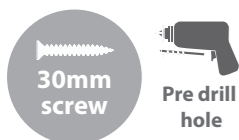

Step 29

Parts Needed- No.13 QTY 2

- No.18 QTY 2

- No.36 QTY 4

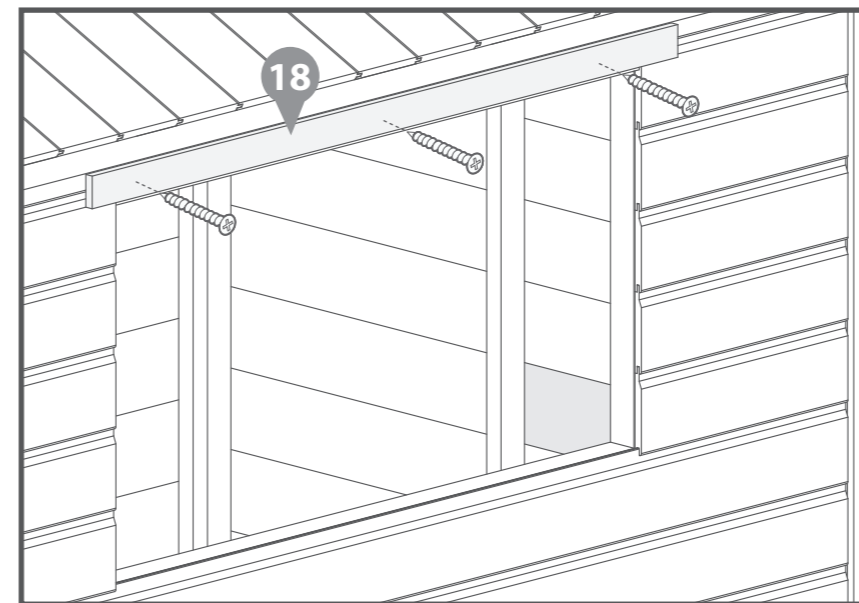

Place the Window Strip (No.18) 11mm above the window gap in the window panel and fix with 3x30mm screws per strip.

6x30mm Screws

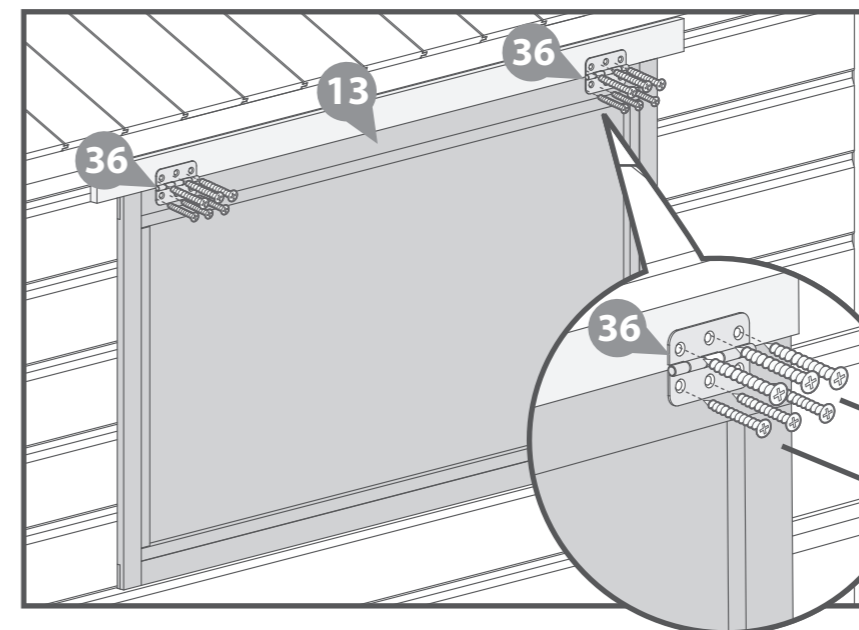

Opening Window

If you would like the windows to be opening use the Butt Hinges (No.36) to attach to the window strip and the Window (No.13) together. Use 30mm screws to fix the butt hinge to the Window Strip and 16mm screws to fix it to the Window.

12x30mm Screws

12x16mm Screws

30mm

16mm

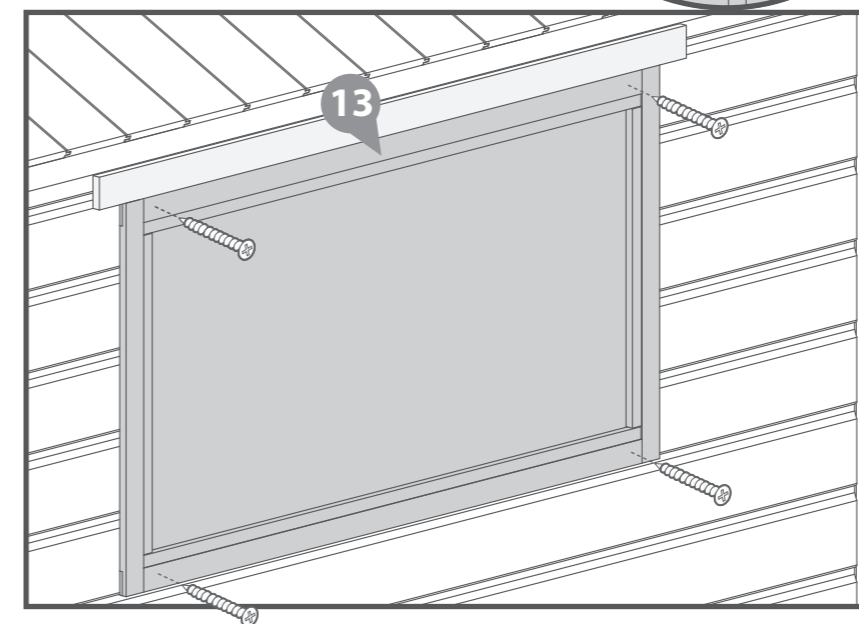

Fixed Window

If you want to fix the windows, instead of fixing butt hinges to the opening window, use 4x30mm screws to attach the window (No.13) to the window side panel as shown in the diagram.

8x30mm Screws



Step 30

Parts Needed- No.32 QTY 2

Fix the Casement Stay (No.32) to the opening window then align the fixings onto the window panel frame.

Ensure the casement stay fits into fixings when closed before screwing them down using 6x16mm screws per casement stay.

12x16mm Screws

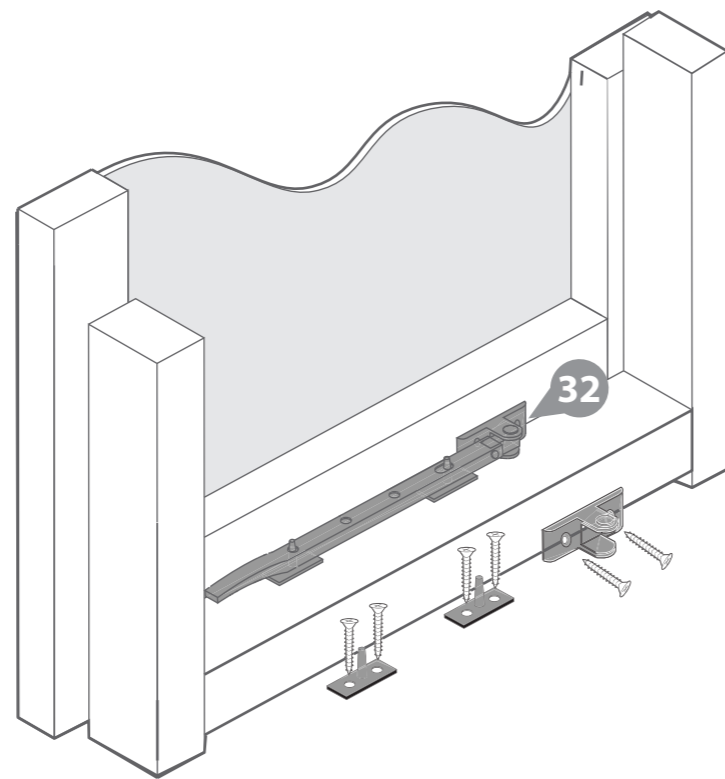
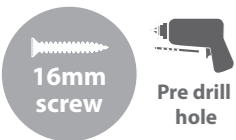

Step 31

Parts Needed- No.19 QTY 7
- No.20 QTY 1

Fit the Cover Trims (No.19) to the building at each corner and panel join, secure in place with 3x30mm screws per cover trim.

Fix the gable cover trim (No.20) to the back of the building using 2x30mm screws, ensuring it sits flush with the fitted cover trim below.

23x30mm Screws

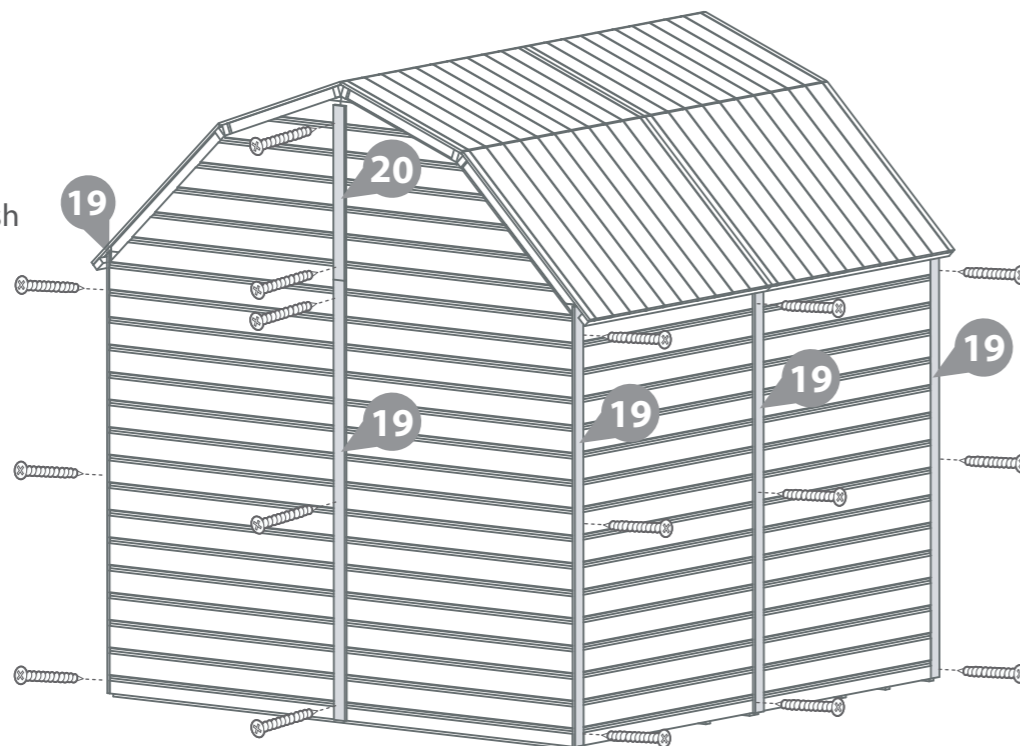

Step 32

Parts Needed- No.37 QTY 1

Cut four strips of felt (No.37) to 2500mm lengths and place onto the roof.

Place the felt flat onto the roof in the order that is stated on the diagram below with a 50mm overhang over each end..

Once the sheets are laid out fix them onto the roof with tacks 100mm apart.

125 x Felt tack

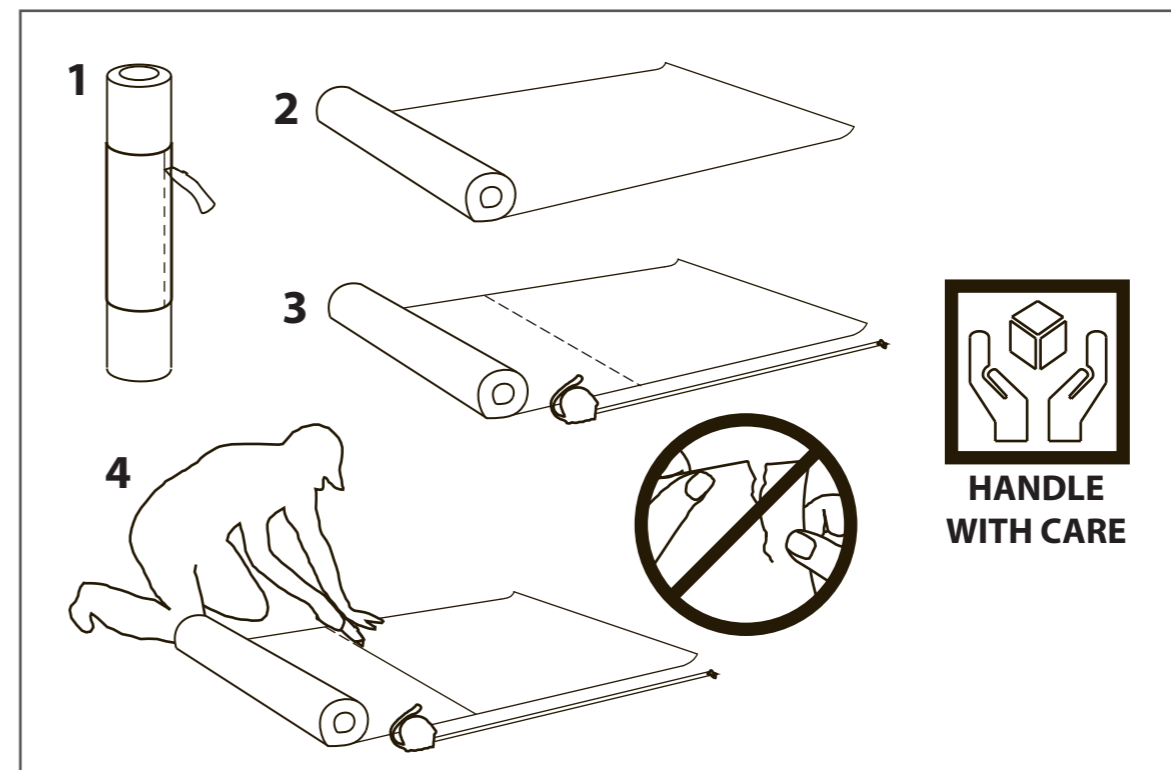
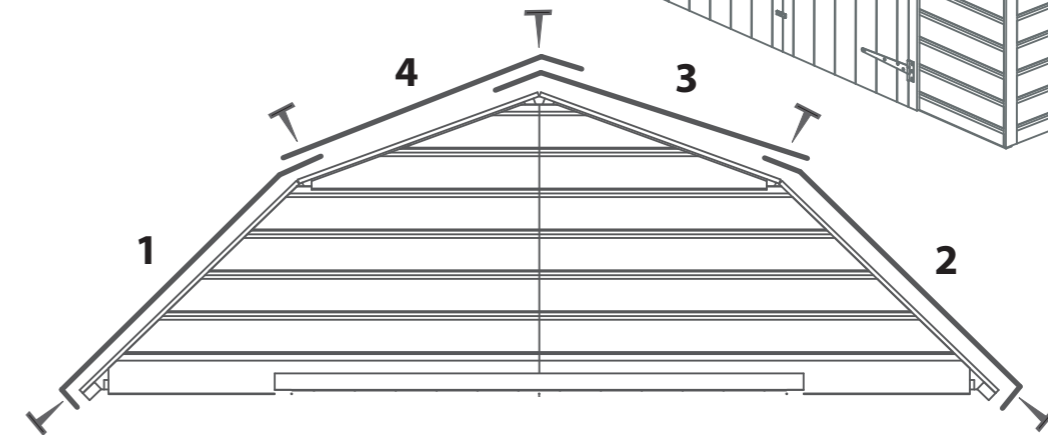
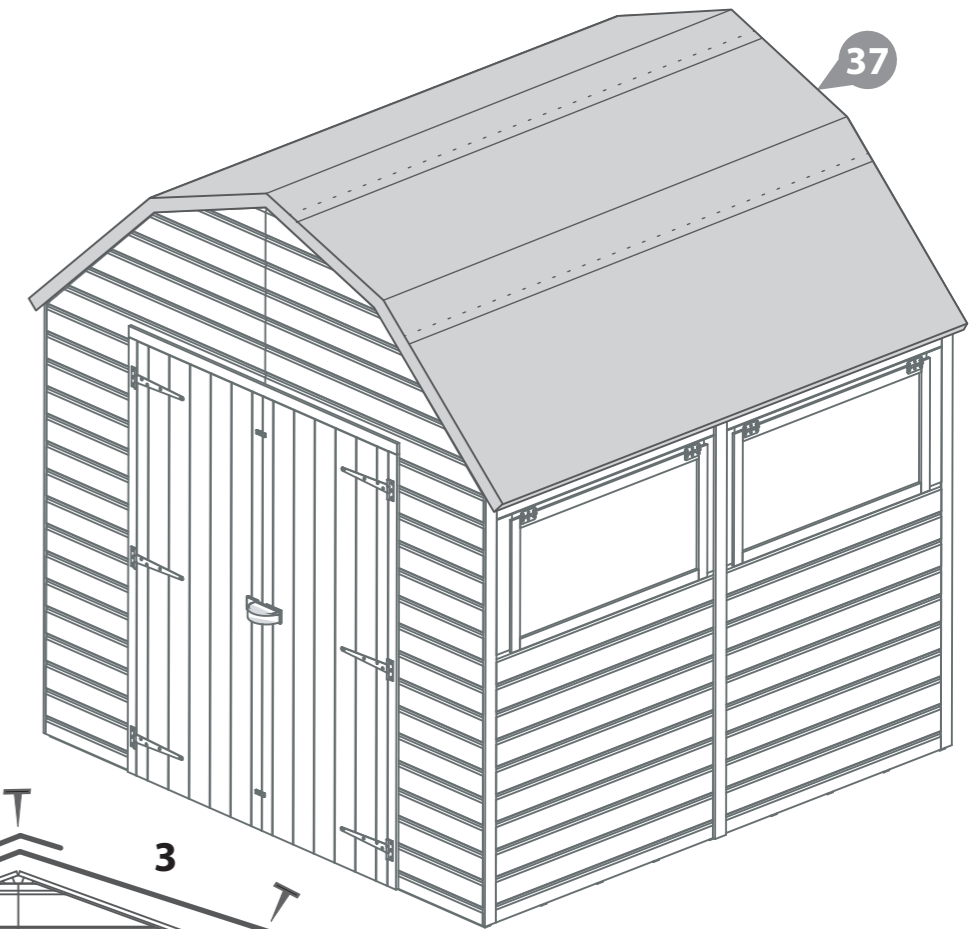

Step 33

Parts Needed- No.25 QTY 4
- No.27 QTY 4

Fix the Fascias (No.25 & No.27) to the front and rear of the building using 3x30mm screws per fascia.

Ensure to screw through the boards into the framing.

24x30mm Screws

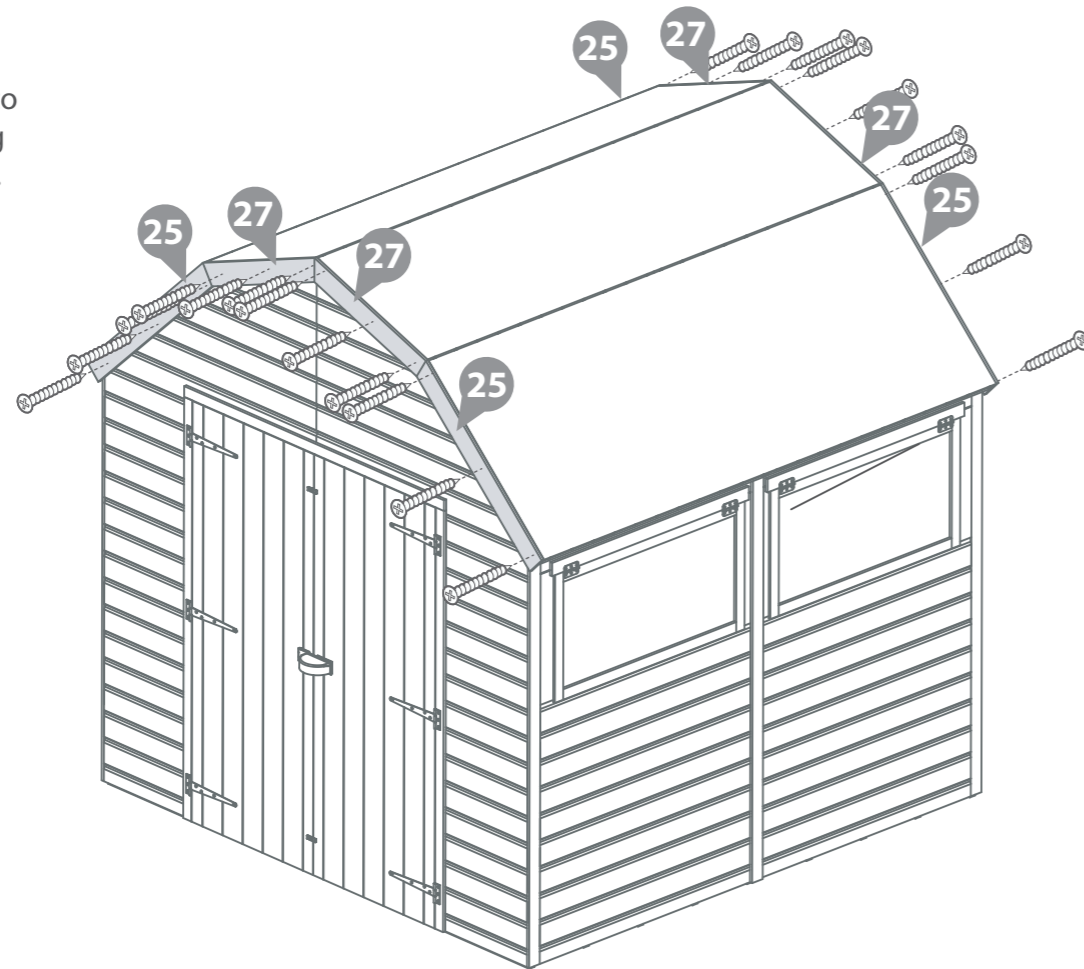

Step 34

Parts Needed- No.24 QTY 1
- No.26 QTY 2

Fix the Barge Board (No.24 and No.26) to the front of the building using 3x30mm screws per Barge Board.

Ensure to screw through the boards into the Gable top cladding.

9x20mm Screws

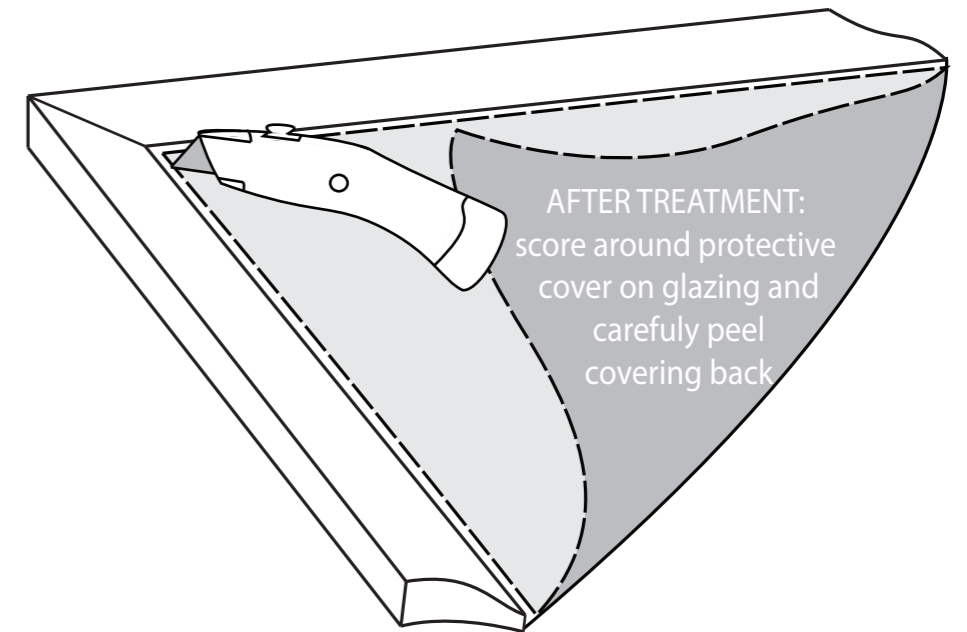
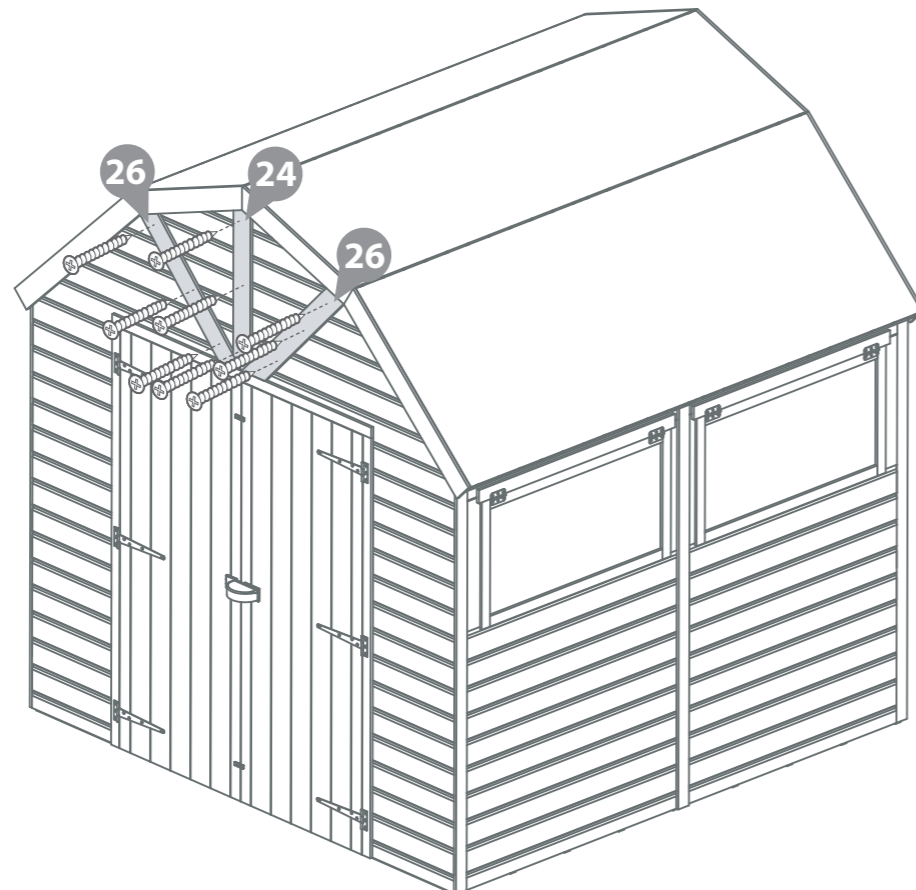

All our garden buildings have been designed and manufactured with care and attention to be the perfect addition to your outdoor space. To ensure you do get the best out of your new garden building and to increase the longevity we advise that you follow the product instructions and our manufacturer's recommendations as detailed below. Thank you for choosing a Mercia Garden product!

1 Choosing the most suitable location for your garden building...

A minimum of 60cm should be left around the perimeter of your garden building to allow access for maintenance, annual treatment and to allow air flow around the building.

Where possible you should avoid placing your garden building underneath large trees to prevent the tree causing damage to the building.

2 Preparing the base for your garden building...

All our buildings must be built on a firm, level base to ensure the longevity of the building and prevent the wood from distorting. We recommend either concrete, concrete slabs or a wooden base, such as our 'Portabase'.

The base should be slightly smaller than the external measurement of the building, i.e. the cladding should overlap the base, creating a run off for water and preventing water from pooling underneath the building.

We also recommend that the floor of the garden building is a minimum of 25mm above the surrounding ground level to avoid flooding.

3 After installation...

Once your garden building has been installed it will need to be treated as soon as possible and annually to prevent the timber from deteriorating and to waterproof it. This is required to maintain the anti-rot guarantee.

Dip Treated buildings - Require a preservative treatment to protect against rot and decay and a waterproof treatment to prevent water ingress

Pressure Treated buildings - Require a waterproof treatment to prevent water ingress

Log Cabins/Insulated Garden Rooms - Are supplied untreated and require a preservative and waterproofing treatment

We also recommend using a silicon sealant on the inside and outside of the windows as soon as possible after assembly and treatment to fully seal the windows.

Roofing felt/covering should be checked annually and replaced or fixed accordingly.

4 General maintenance and wood characteristics

As wood is a natural material it may be affected by the following:

Shrinkage and warping - The timber used in the construction of your garden building will have retained some of its natural moisture content. The moisture content of the timber will vary, depending upon prevailing environmental conditions, which will result in the components either naturally expanding or contracting. As the components dry out shrinkage may occur. A good waterproofing treatment from the start is the best protection to minimise the effect of moisture loss/intake.

In extended periods of very warm weather getting some moisture to the building will help the overall balance. You can do this by spraying it down lightly with a garden hose. In contrast after snow fall try to remove the snow as best as possible from the roof to prevent moisture intake and to remove the extra weight.

Top tip - using a garden brush will help you to reach the highest part of the building to remove snow and any debris left from bad weather.

Damp and mould - During the winter months, cold and damp conditions can result in an increased amount of moisture within your garden building, especially when used infrequently. Condensation can form on the timber and other items stored within your garden building. If left this moisture is likely to cause mould and mildew. To prevent the build-up of moisture, we recommend leaving the door or windows of your building open from time to time, to allow the fresh air to circulate. We also advise against storing wet or damp items in your garden building as this will also increase the level of moisture in the building. If mould or mildew does start to form within your building we recommend using an anti-mould cleaner to remove it and to prevent it spreading, which if left untreated could permanently damage your garden building.

Splits, cracks and knots - You may notice small splits and cracks in some components or holes may appear where knots shrink and fall out. This will not affect the structure of your Garden building however if you wish to fill them this can be easily done using any good quality wood filler.

Sap - is naturally occurring in wood and may appear in some boards of your garden building. If you wish to remove the sap, we advise waiting until it is dry and then using a sharp knife to carefully remove it. If the removal of the sap causes a hole in the timber, we recommend using a good quality wood filler to fill it.

For more handy hints and tips on how to care and maintain your garden building please refer to the MGP Customer Portal at www.mgplogistics.co.uk

Any further questions?

Contact our
Customer Service
Team on:
01636 821215

1 Manufacturer's Warranty

All Mercia Garden Products are supplied with a 1 year warranty on all parts against manufacturing defects.
This warranty does not cover movement, warping or splitting of timber products over time.

This warranty will be voided if any of the following occur:

1. The building has been customised or modified/adapted in any way.
2. The person claiming is not the original purchaser of the building.
3. Any damage has been caused by or as a result of misuse.
4. The building has not been maintained and cared for in accordance to our advisories and manufacturer's recommendations.
5. The building has not been treated annually or as per the manufacturer's recommendations, please ensure receipts are kept to validate this claim.
6. The building has not been erected, fitted or installed as per the supplier instructions.
7. The building has not been erected on a suitable sized firm flat, solid level concrete/slab base or placed on pressure treated bearers.
8. The building is or has been placed with 2 feet (60cm) of any obstructions (walls, trees, plants, fences etc.) which can allow moisture to penetrate the timber.
9. The roofing felt has been incorrectly fitted or damaged allowing water ingress, or not properly maintained.
10. Any windows and joints have not been sealed, inside and out, with silicone or other watertight sealant.
11. Any timber has been cut, pierced or drilled without subsequent application of approved cut-end treatment.

2 Anti-rot Guarantee

Mercia Garden Products offer a 10 year anti-rot guarantee on all dip treated (a preparatory treatment) and 15 years on all pressure treated products. This guarantee covers solid timber against rot, decay, blue stain and insect attack.

To validate the guarantee the building must be treated with a recognised wood preserver/water proof top coat (as detailed within manufacturer's recommendations) as soon as possible after assembly and annually thereafter.

This guarantee does not cover movement, warping or splitting of timber products over time.

This guarantee will be voided if any of the following occur:

1. The building has been customised or modified/adapted in any way.
2. The person claiming is not the original purchaser of the building.
3. Any damage is caused by or as a result of misuse.
4. The building has not been maintained and cared for in accordance to our advisories and manufacturer's recommendations.
5. The building has not been treated annually or as per the manufacturer's recommendations, please ensure receipts are kept to validate this claim.
6. The building has not been erected, fitted or installed as per the supplier instructions.
7. The building has not been erected on a suitable sized firm flat, solid level concrete/slab base or placed on pressure treated bearers.
8. The building is or has been placed with 2 feet (60cm) of any obstructions (walls, trees, plants, fences etc.) which can allow moisture to penetrate the timber.
9. The roofing felt has been incorrectly fitted or damaged allowing water ingress, or not properly maintained.
10. Any windows and joints have not been sealed, inside and out, with silicone or other watertight sealant.
11. Any timber has been cut, pierced or drilled without subsequent application of approved cut-end treatment.