

General Instructions

Please retain product label and instructions for future reference

01MODP0804-V2
8X4 MODULAR PENT

BEFORE YOU START PLEASE READ INSTRUCTIONS CAREFULLY

- Check the pack and make sure you have all the parts listed.
- When you are ready to start, make sure you have the right tools at hand (not supplied) including a Phillips screwdriver, Stanley knife, Wood saw, Step ladder, Hammer and a Drill with 2mm bit.
- Ensure there is plenty of space and a clean dry area for assembly.

LOCATION FOR YOUR GARDEN BUILDING

A minimum of 60cm should be left around the perimeter of your garden building to allow access for maintenance, annual treatment and to allow air flow around the building.

Where possible you should avoid placing your garden building underneath large trees to prevent the tree causing damage to the building.

TIMBER

As with all natural materials, timber can be affected during various weather conditions. For the duration of heavy or extended periods of rain, swelling of the wood panels may occur. Warping of the wood may also occur during excessive dry spells due to an interior moisture loss. Unfortunately, these processes cannot be avoided but can be helped. It is suggested that the outdoor building is sprayed with water during extended periods of warm sunshine and sheltered as much as possible during rain or snow.

Once your garden building has been installed it will need to be treated as soon as possible and annually to prevent the timber from deteriorating and to waterproof it. This is required to maintain the anti-rot guarantee.

Dip Treated buildings - Require a preservative treatment to protect against rot and decay and a waterproof treatment to prevent water ingress

Pressure Treated buildings - Require a waterproof treatment to prevent water ingress

Log Cabins - Are supplied untreated and require a preservative and waterproofing treatment.

BUILDING A BASE

When thinking about where the building and base is going to be constructed: Ensure that there will be access to all sides for maintenance work and annual treatment.

Ensure the base is level and is built on firm ground, to prevent distortion. Refer to diagrams for the base dimensions, The base should be slightly smaller than the external measurement of the building, i.e. The cladding should overlap the base, creating a run off for water. It is also recommended that the floor be at least 25mm above the surrounding ground level to avoid flooding.

TYPES OF BASE

- Concrete 75mm laid on top of 75mm hard-core.
- Slabs laid on 50mm of sharp sand.

Whilst all products manufactured are made to the highest standards of Safety and in the case of childrens products independently tested to EN71 level, we cannot accept responsibility for your safety whilst erecting or using this product.

Refer to the instructions pages for your specific product code



x2

All buildings should be erected by two adults



Winter = High Moisture = Expansion
Summer = Low Moisture = Contraction



2mm Drill bit

For ease of assembly, you **MUST** pilot drill all screw holes and ensure all screw heads are countersunk.



CAUTION

Every effort has been made during the manufacturing process to eliminate the prospect of splinters on rough surfaces of the timber. You are strongly advised to wear gloves when working with or handling rough sawn timber.



For ease of assembly, you will need a tape measure to check dimensions of components.

Screws & Nails



Measure overall length

Bolts



Measure under the head

To identify the fixings required for each step use a measuring tape.

Protim Aquatan T5 (621)

Your building has been dip treated with **Aquatan**.

Aquatan is a water-based concentrate which is diluted with water, the building as been treated by the correct application of Aquatan solution and then allowed to dry.

Aquatan is a decorative finish to colour the wood, which is applied industrially to timber fence panels and garden buildings.

Aquatan undiluted contains: boric acid, sodium hydroxide 32% solution, aqueous mixture of sodium dioctyl sulphosuccinat and alcohols: 2, 4, 6-trichlorophenol.



REGISTER FOR YOUR
ANTI-ROT
GUARANTEE TODAY

PLEASE SCAN HERE:



For assistance please contact customer care on: 01636 821215

Mercia Garden Products Limited,
Sutton On Trent,
Newark,
Nottinghamshire,
NG23 6QN

www.merciagardenproducts.co.uk



01MODP0804-V2

Please retain product label and instructions for future reference

Overall Dimensions:

Width = 2490 mm
Depth = 1215 mm
Height = 2150 mm

Base Dimensions:

Width = 2467mm
Depth = 1185mm

Before assembly
please make sure you have a
suitable base ready to erect your
building



MADE IN GREAT BRITAIN

See back of instructions
for Combi greenhouse
assembly

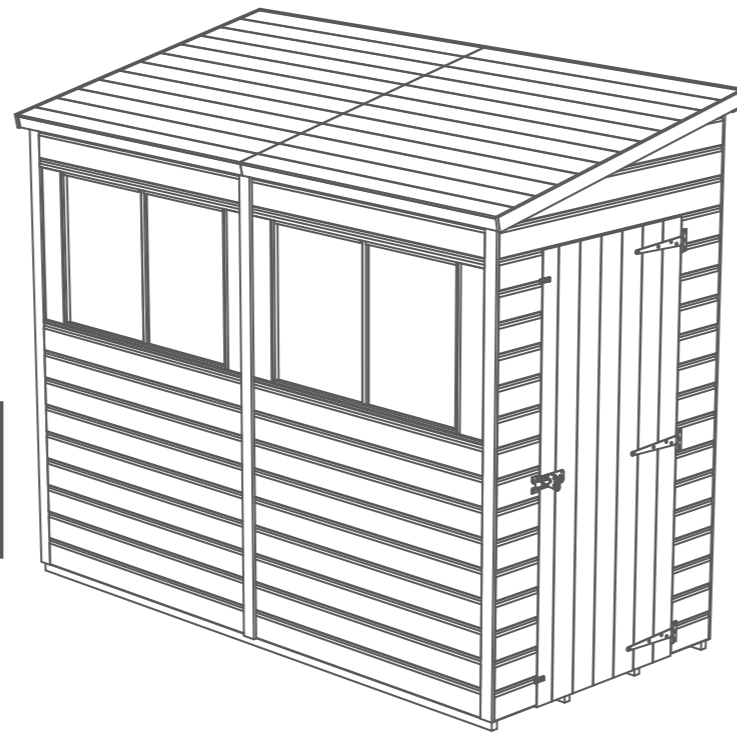

Building Content:

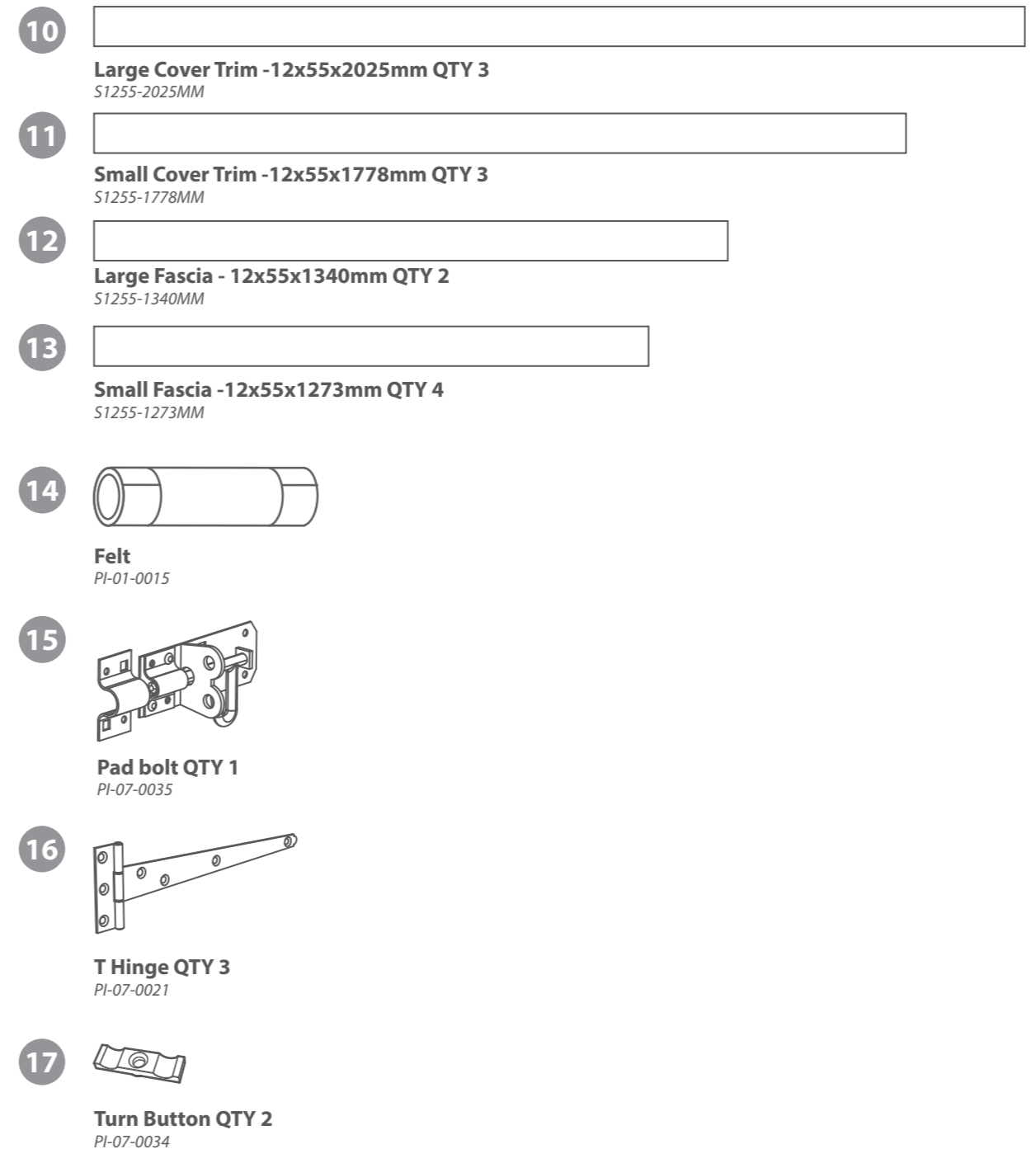
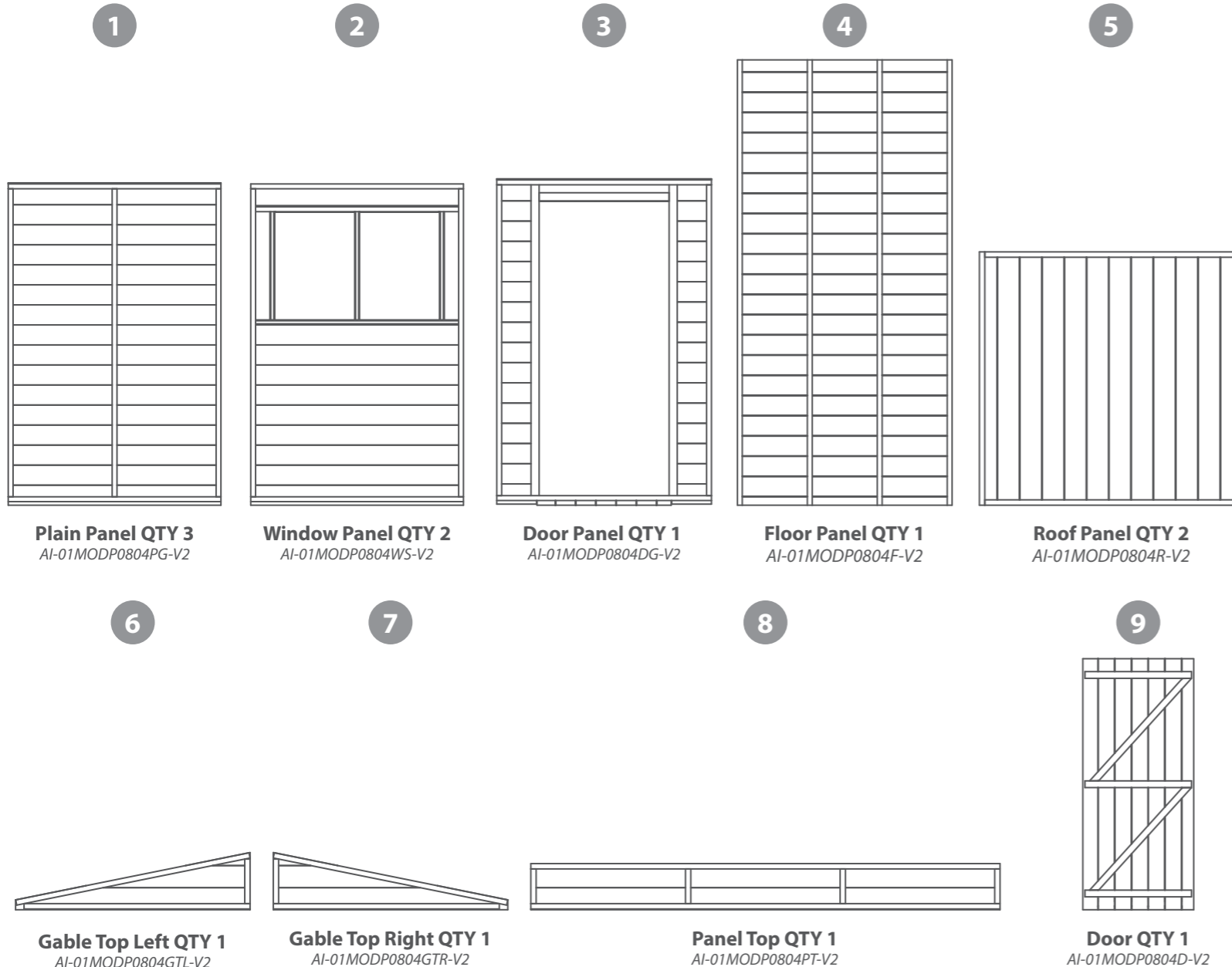

Nail Bag

There may be extra screws present in the nail bag



Pre Assembly

Before assembling remove the transportation blocks from the bottom of each panel.

Take care removing the blocks as to not damage the panels. Tap with a flat headed screwdriver and hammer.

Dispose of the blocks once removed.

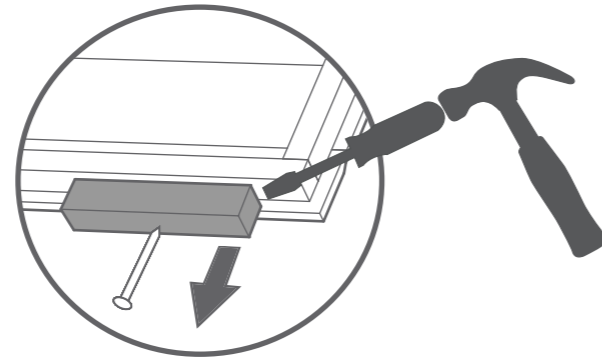

Step 2

Parts needed - No. 4 QTY 1

Place the floor (No. 4) on a firm and level base, ensure base has suitable drainage free from areas where standing water can collect. (See front page on base requirements).

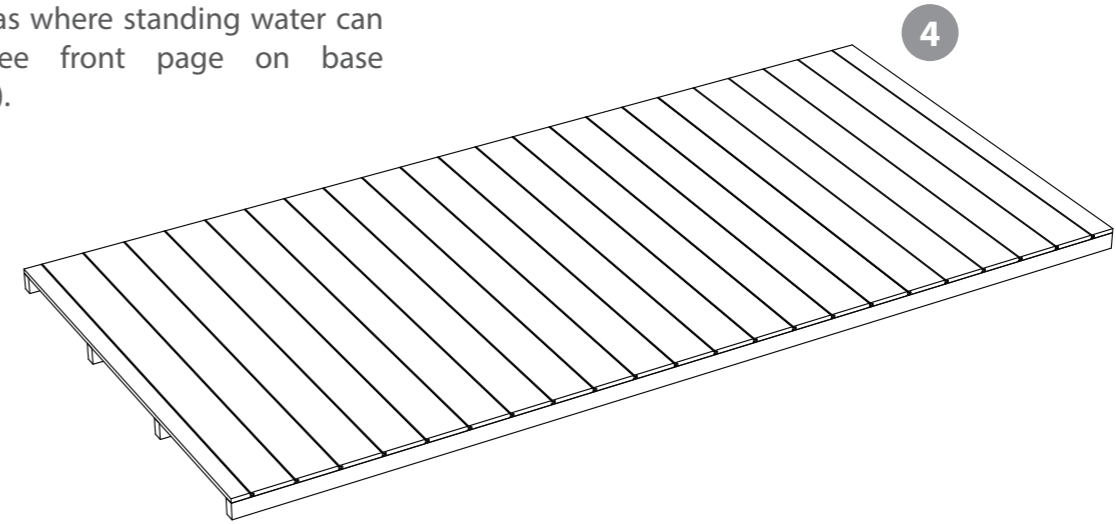

Step 1

Parts needed - No. 3 QTY 1
No. 9 QTY 1
No. 16 QTY 3

Fix the T Hinges (No.16) onto the door (No.9) and door frame (No.3) in line with the door blocks.

21x30mm screws.

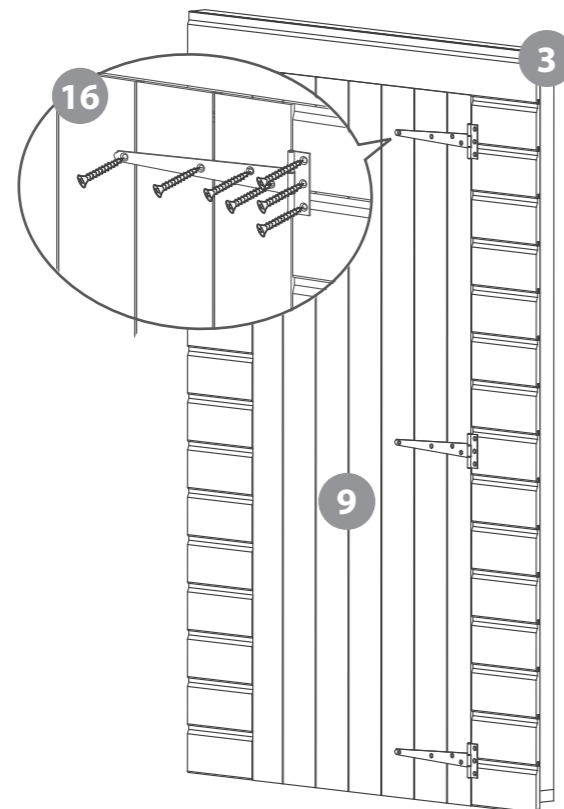
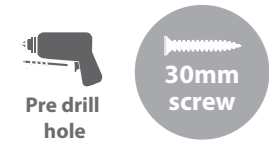

Step 3

Parts needed - No. 1 and/or 2

**** Please note: The side panels are all interchangeable and can be positioned in a variety of configurations, Decide which works best before assembly. (see end of step 12)**

a Fix the corners with 3x 50mm screw as shown in diagram.

b Do not secure the building to the floor until the roof is fitted. Fix the panels onto the floor using 50mm screws in alignment with the floor joists.

10x50mm screws.

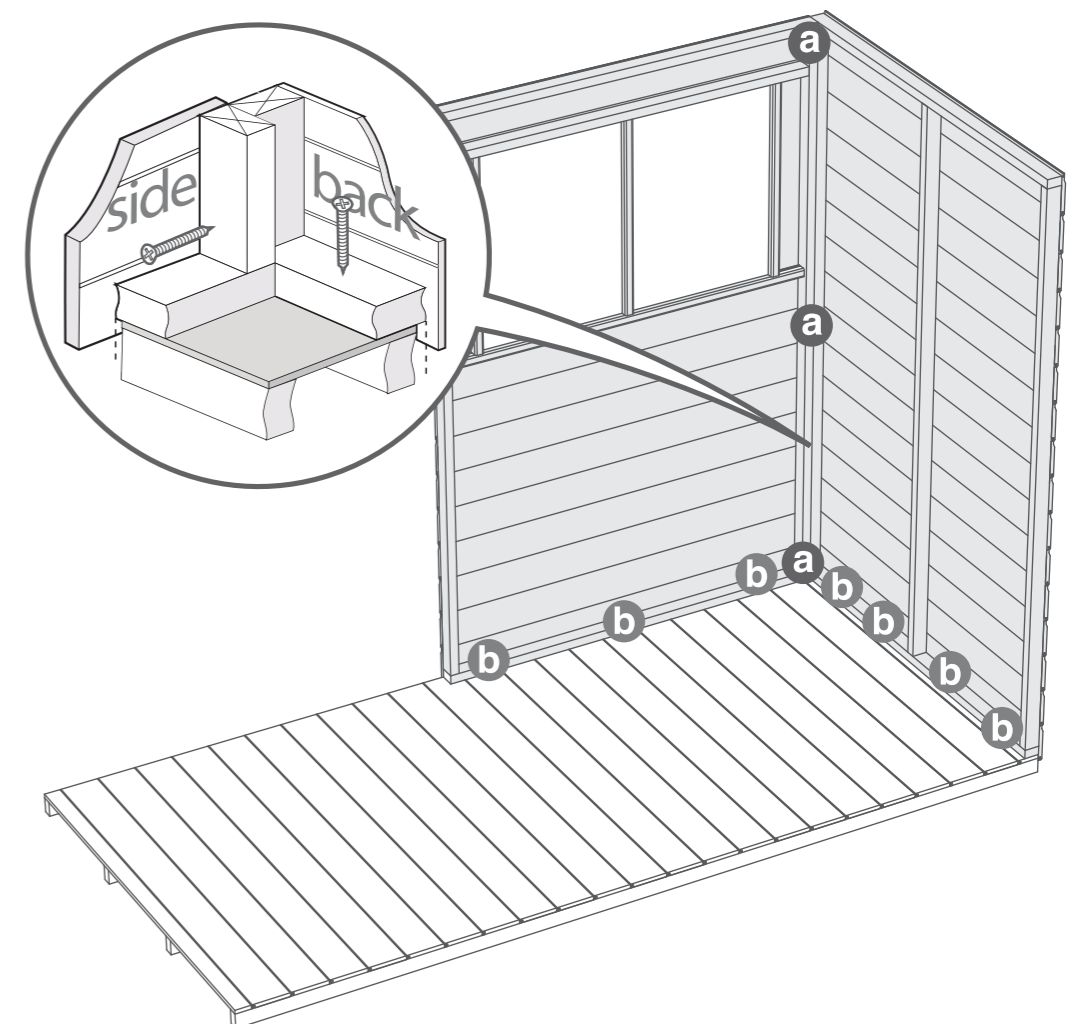

Step 4

Fix the second set of panels using same method shown in step 2.

12x50mm screws.

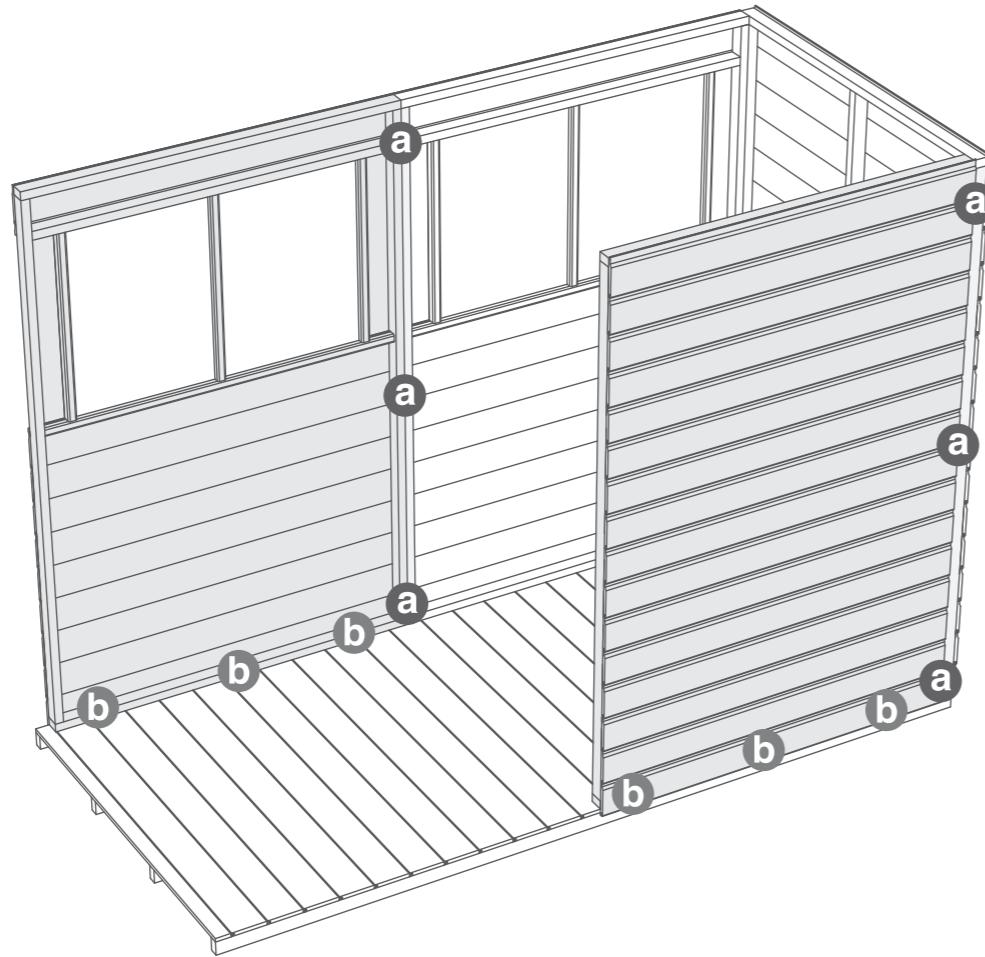
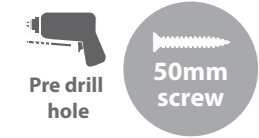

Step 5

**Parts needed - No. 1 or 2
No. 3 QTY 1**

Fix the last set of panels using same method shown in step 2.

Position the panels so there is equal spacing between the floor and cladding on all four sides.

16x50mm screws.

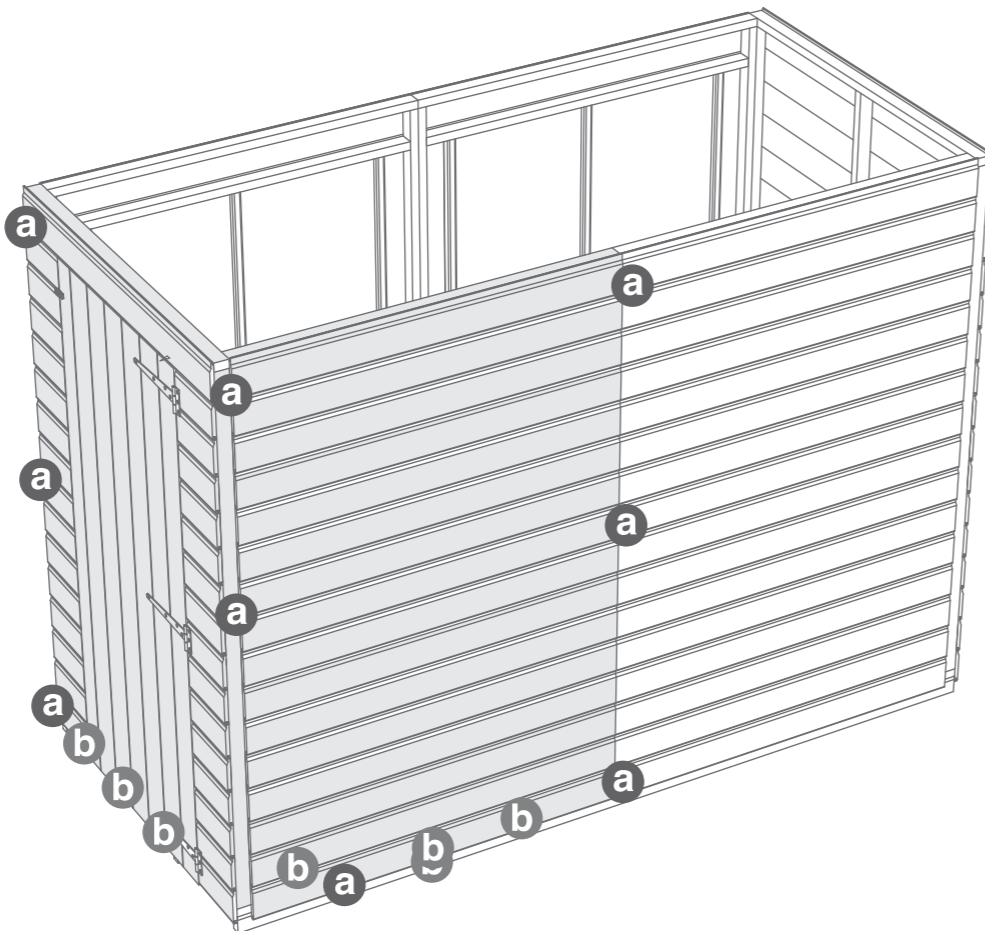
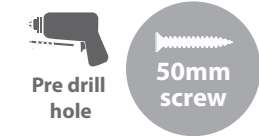

Step 6

**Parts needed - No. 6 QTY 1
No. 7 QTY 1**

Place the left (**No. 6**) and right (**No. 7**) Gable tops on top of the end panels. Make sure the the cladding slots together and fix into position using 50mm screws.

6x50mm screws.

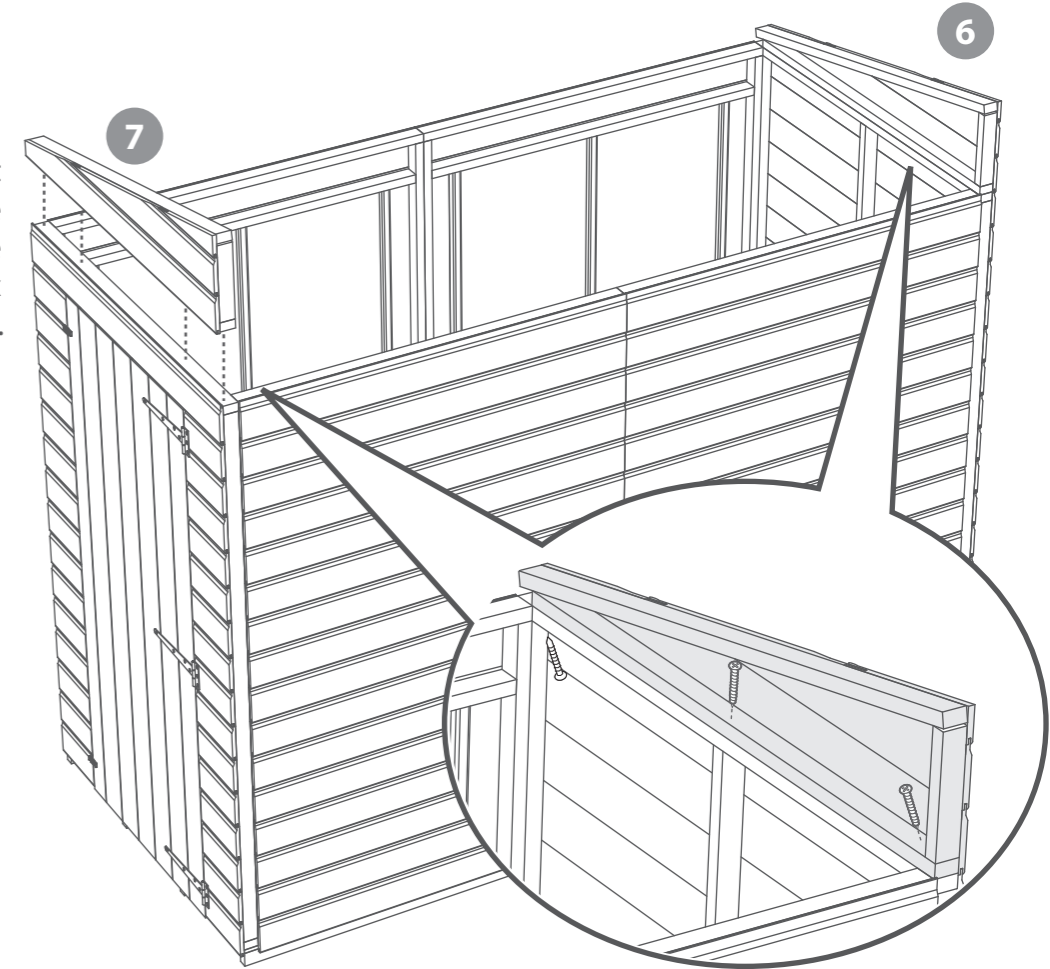

Step 7

Parts needed - No. 8 QTY 1

Place the top panel (**No.8**) on top of side panels as shown and fix using 5 x 50mm screws.

5x50mm Screws

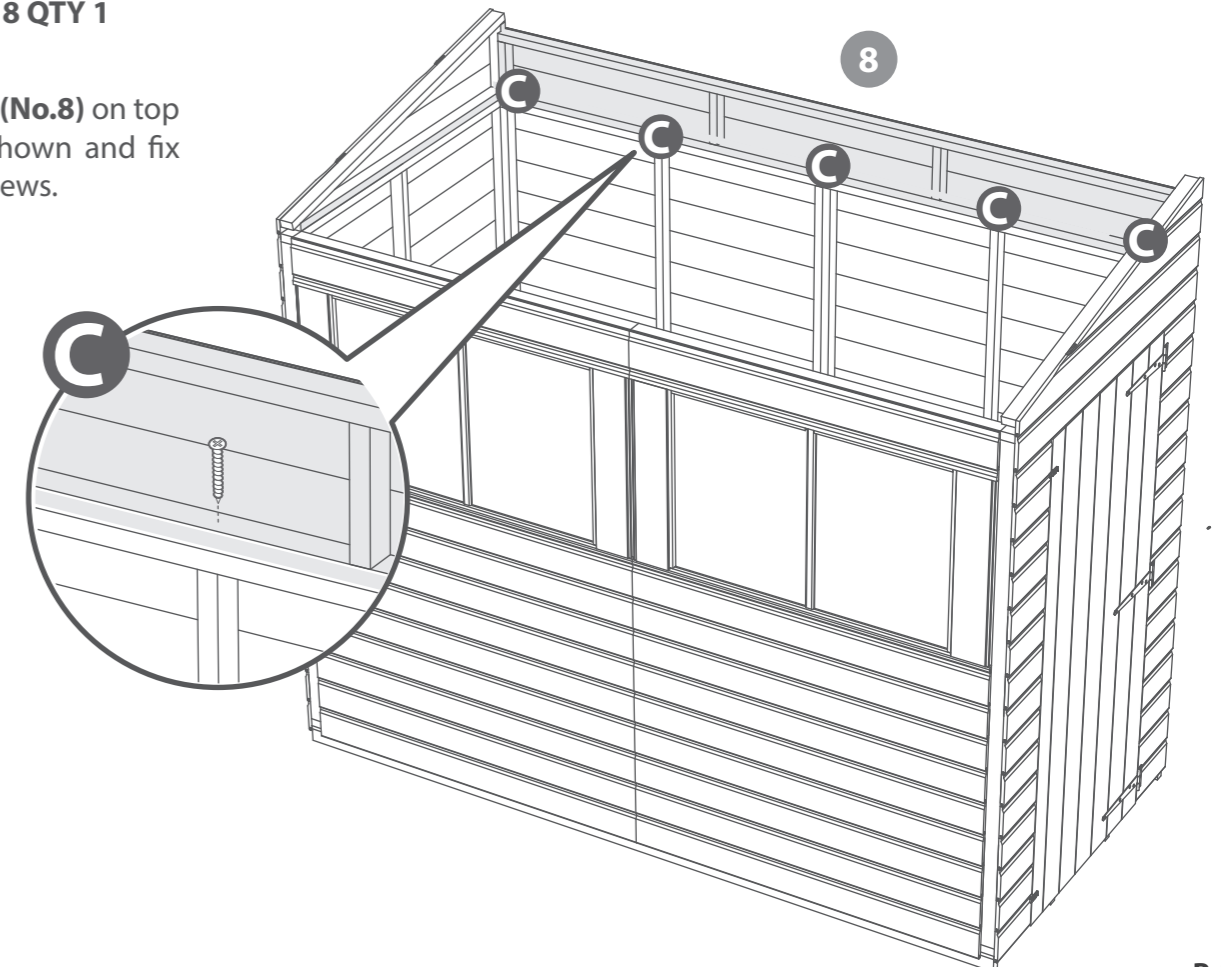
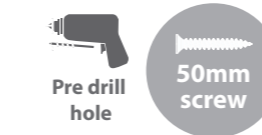

Step 8
Parts needed - No. 5 QTY 2

Slide the roof panels (No. 5) on top and push up to ensure that the roof overhang is at the top side of the building. Fix roof using 50mm screws.

10x50mm Screws

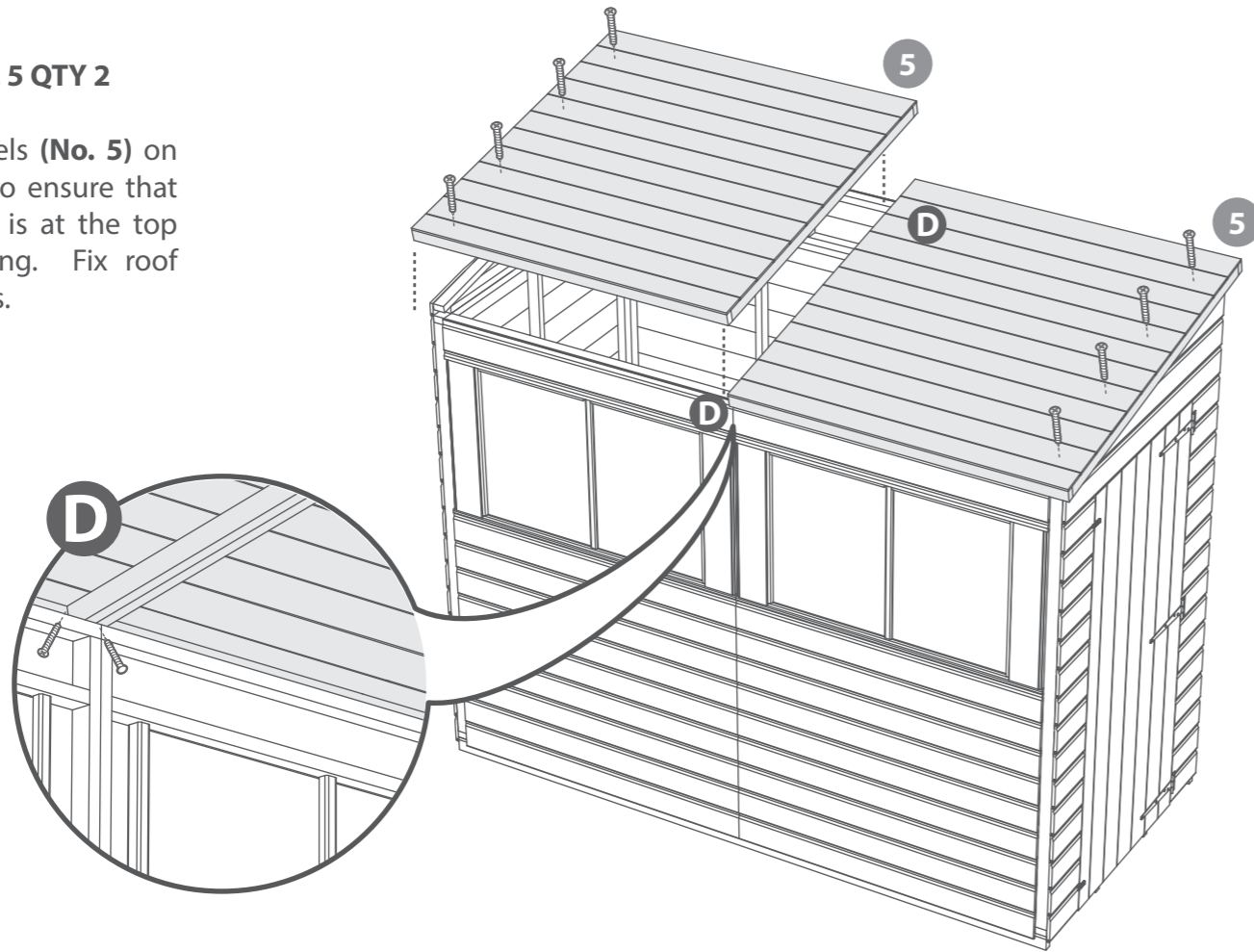

Step 10
Parts needed - No. 11 QTY 3

Fix small cover trims (No. 11) to the lower side of building using 3 x 30mm screws per trim.

9x30mm Screws

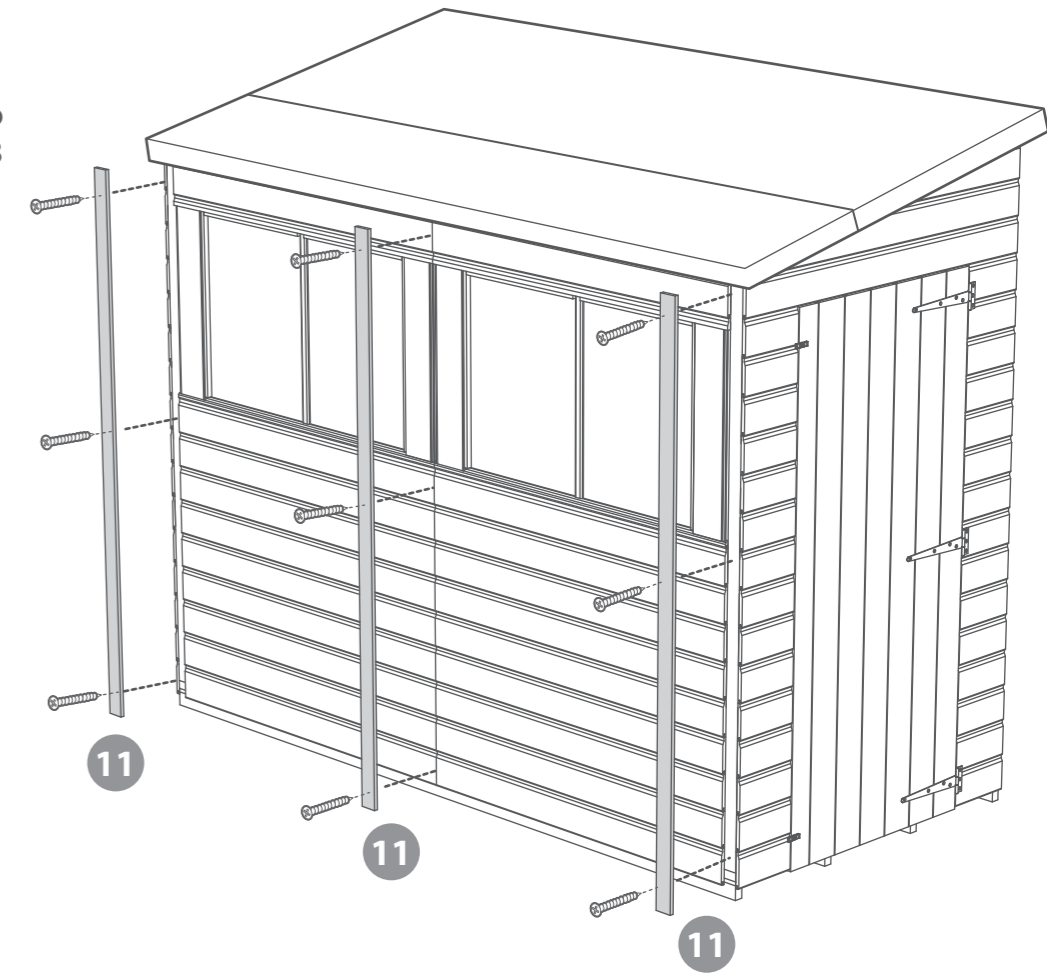
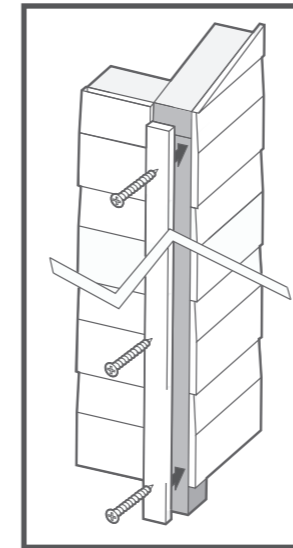

Step 9
Parts needed - No. 14 QTY 1

Cut felt (No. 14) into two sheets ensuring they are both long enough to cover roof with 50mm overhang around the sides. Overlap where the two sheets meet and fix onto roof using felt tacks at 10cm intervals.

60 x Felt Tacks

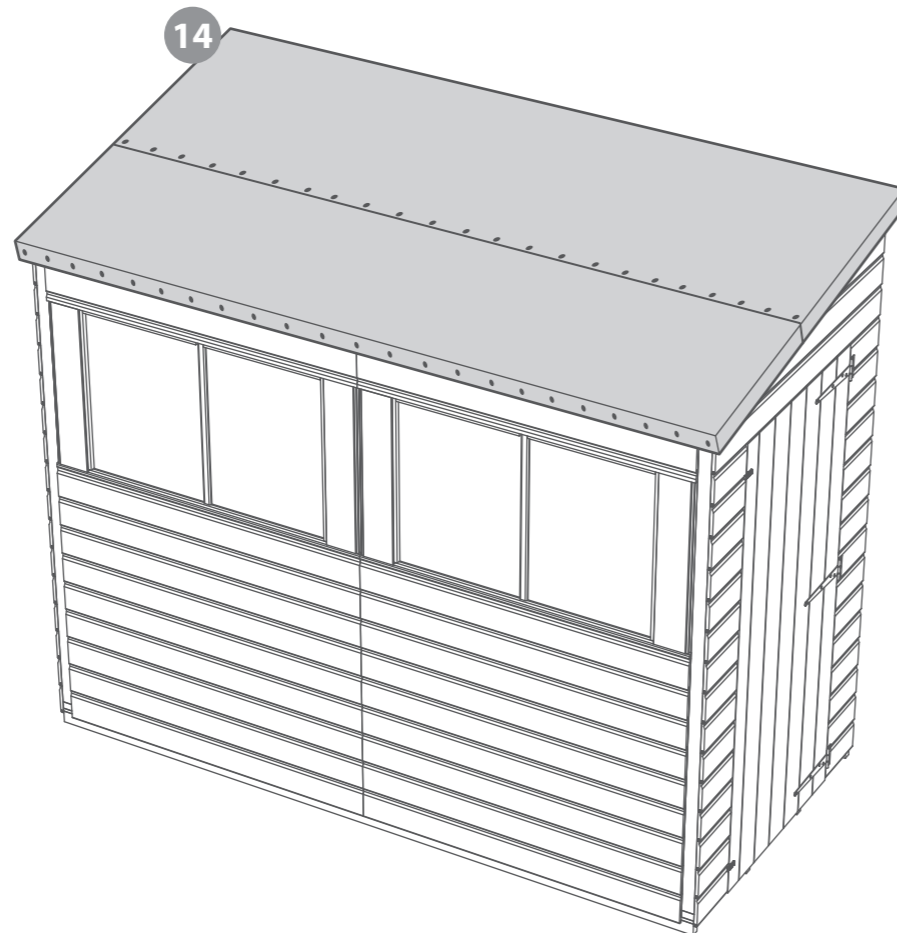
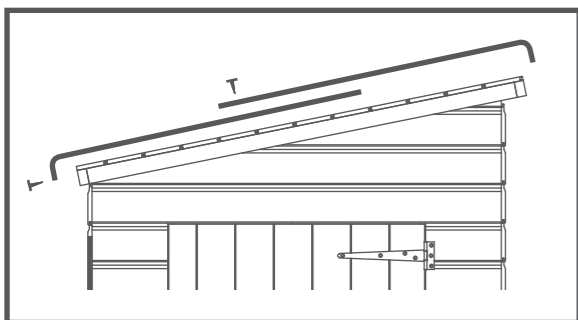

Step 11

Parts needed - No. 10 QTY 3

Fix large cover trims (No. 10) to the other side of building using 3 x 30mm screws per trim.

9x30mm Screws

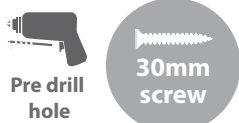

IMPORTANT

Do not fit centre strip if attaching 04LEAN0804 unit (see 04GRECOM0808 assembly)

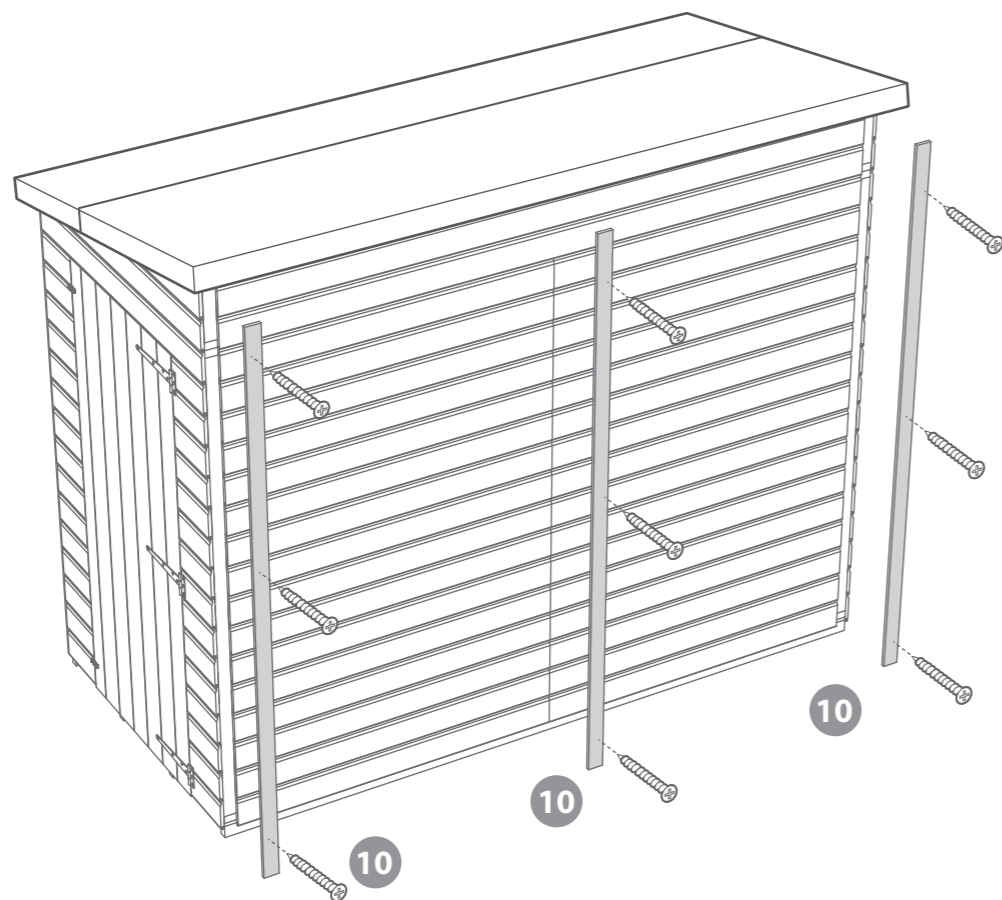

Step 13

**Parts needed - No. 15 QTY 1
No. 17 QTY 2**

Attach the turn buttons (No.17) to the top and bottom of the door using 1x30mm screws per turn button as shown in the illustration.

It is important to fit turn buttons in order to minimise door warping.

Fix Pad bolt (No. 15) using 10x30mm screws. Ensure padbolt and screws are in line with centre door brace.

12x30mm Screws

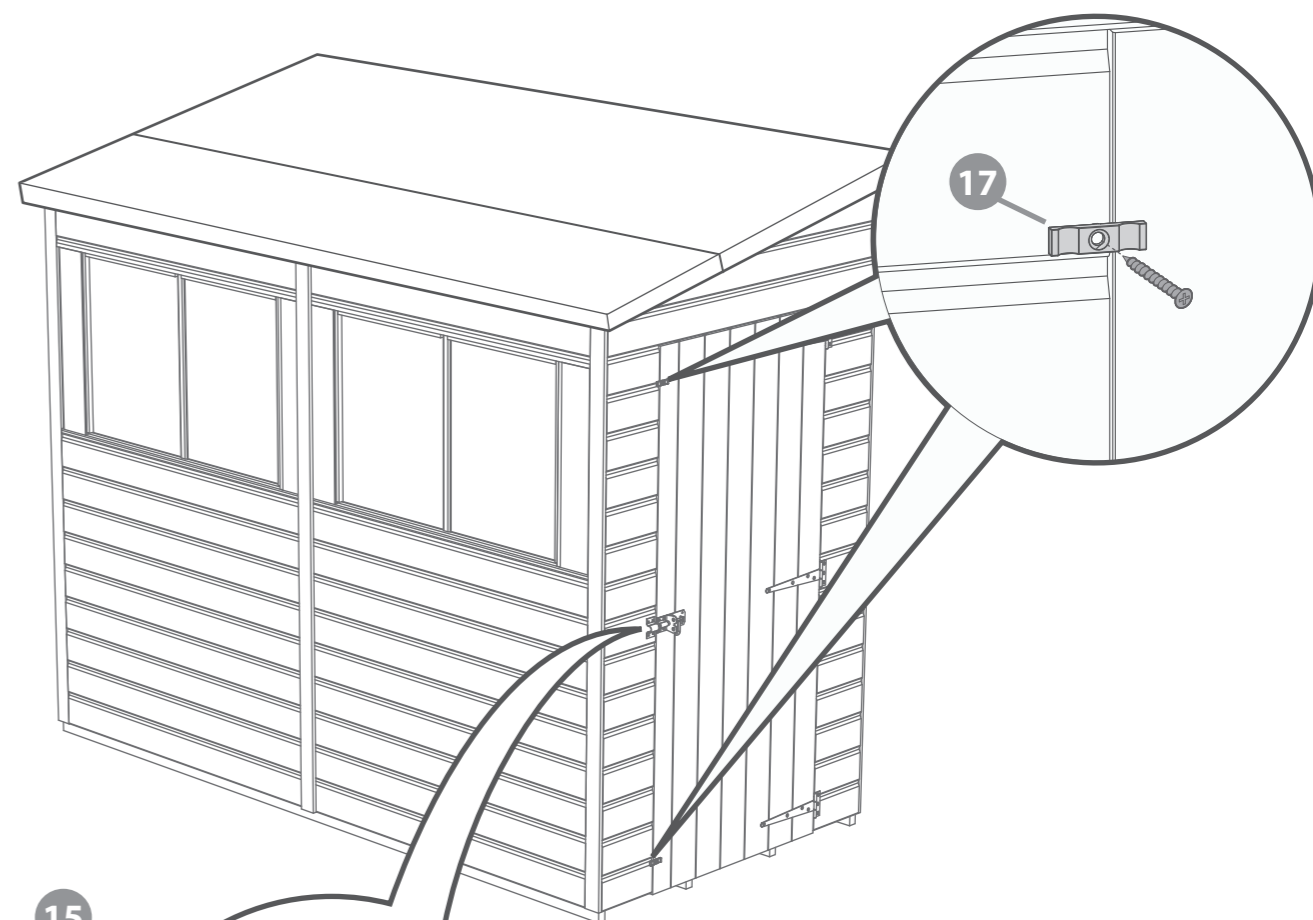

Step 12

**Parts needed - No. 12 QTY 2
No. 13 QTY 4**

Fix fascias (No. 12 & 13) using 40mm screws. Pre drill holes to avoid splitting. Ensure to trap the felt between the fascia and building.

24x40mm Screws

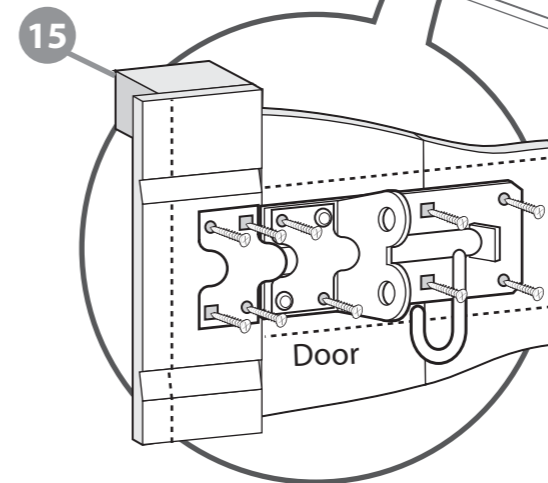
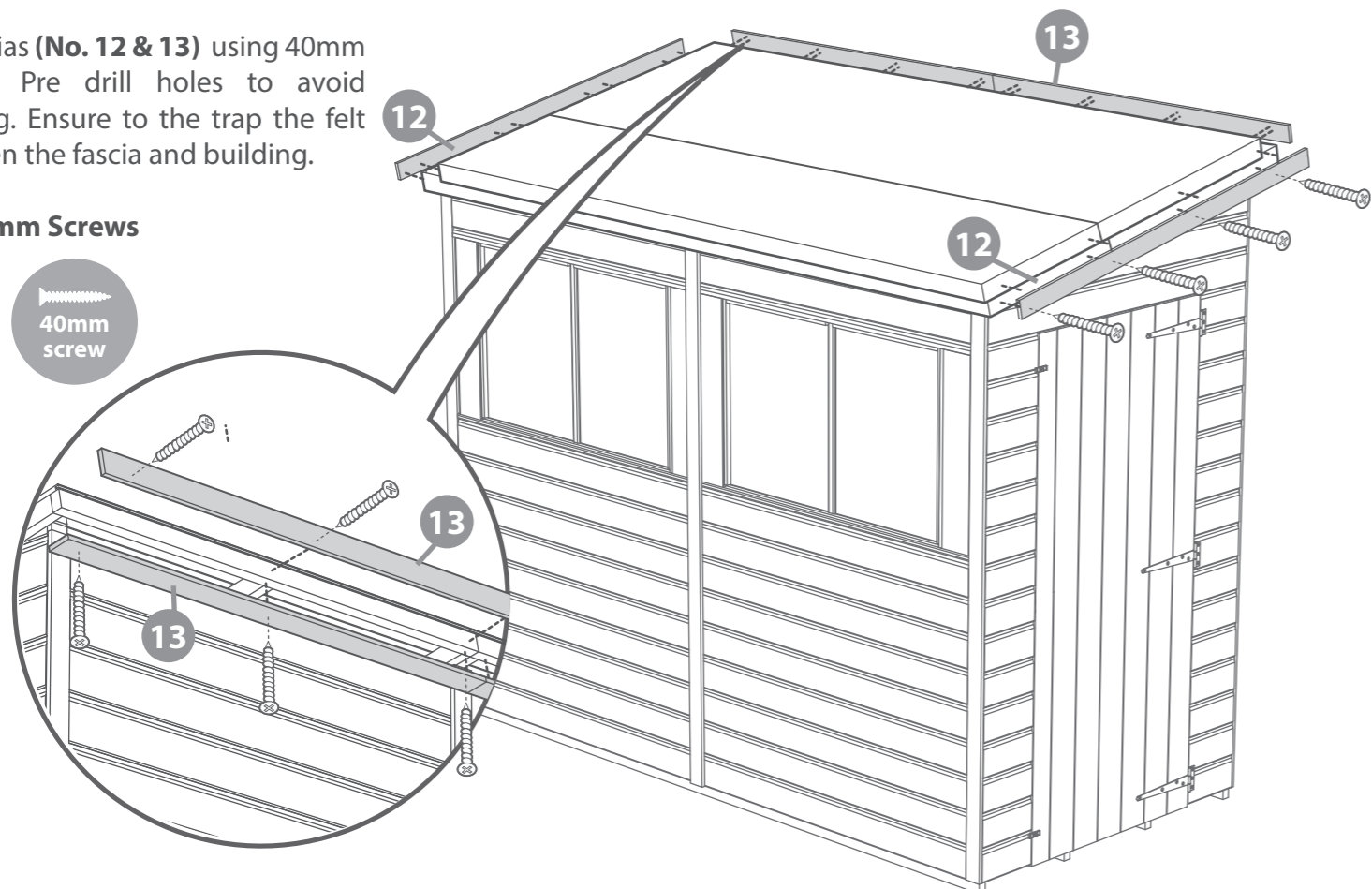
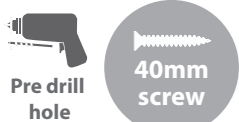

04GRECOM0808-V1 Assembly

Requires 04LEAN0804-V1

Length - 2490mm
Width - 2530mm
Height - 2150mm

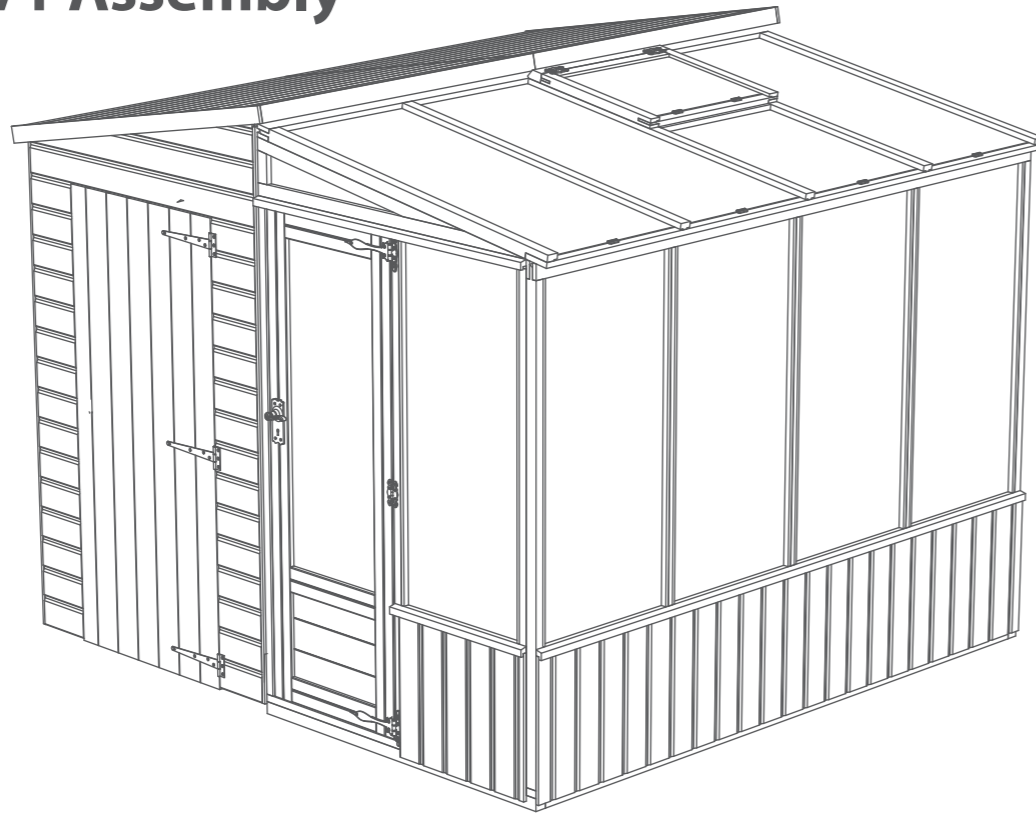

Step 14

Follow the previous steps to assemble shed unit. Ensure the large centre cover trim has not been fitted (see step 11).

Follow instructions for 04LEAN0804-V1 to assemble pent greenhouse unit up against the tall side of the Pent shed.

Pre drill holes first then use 70mm screws in the locations marked below (E).

6x 70mm Screws

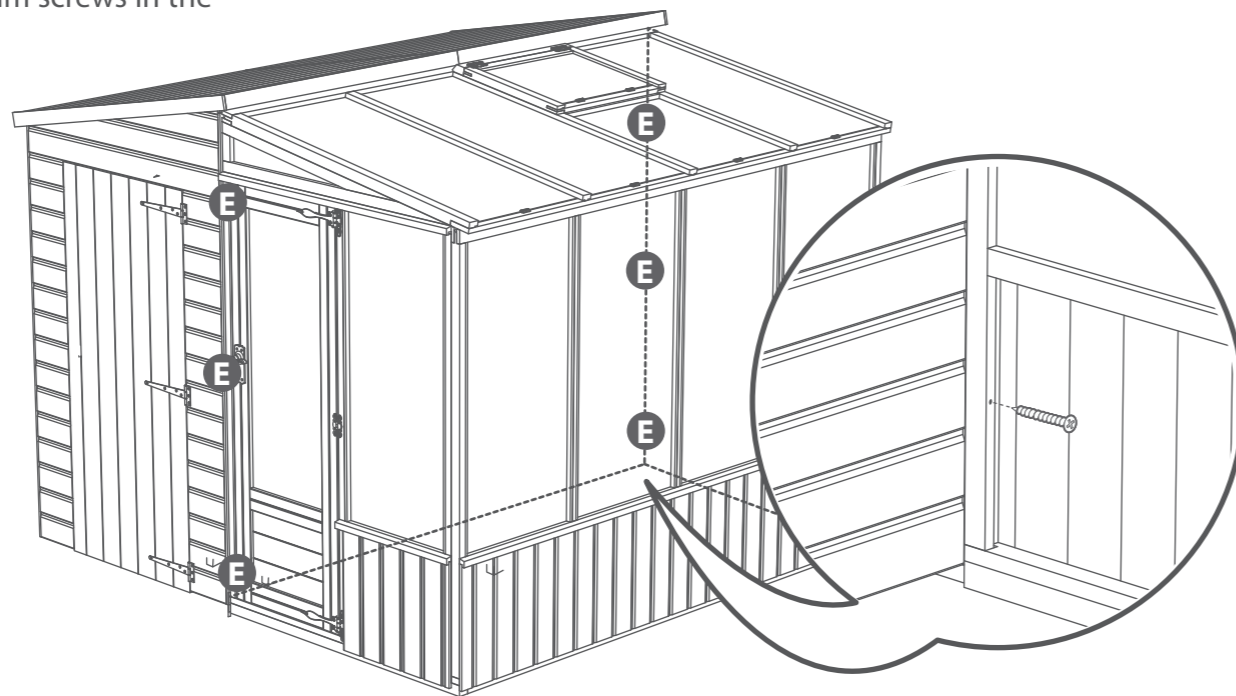

Step 15

Pre drill holes from the shed panel top (No.8) straight into the green house roof panel. Use 4x70mm screws to secure.

4x70mm Screws

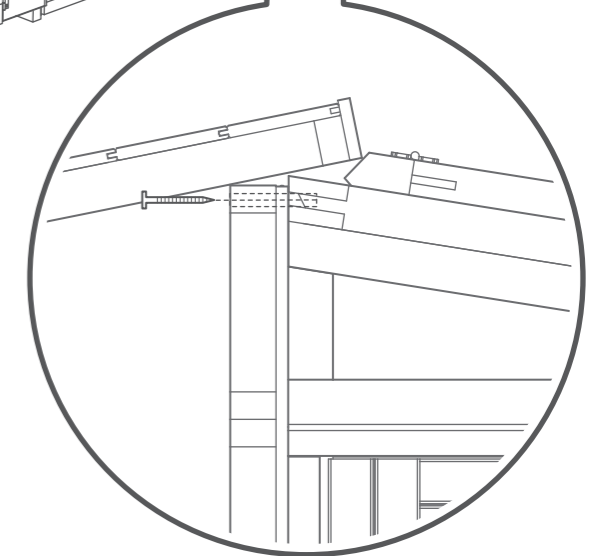
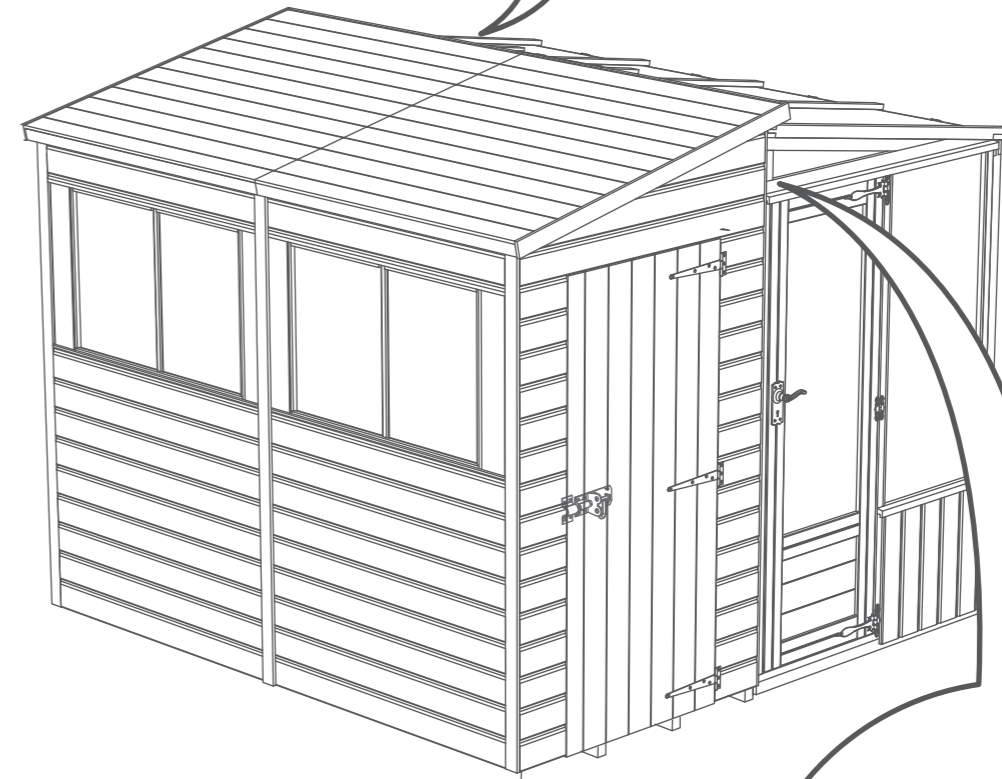
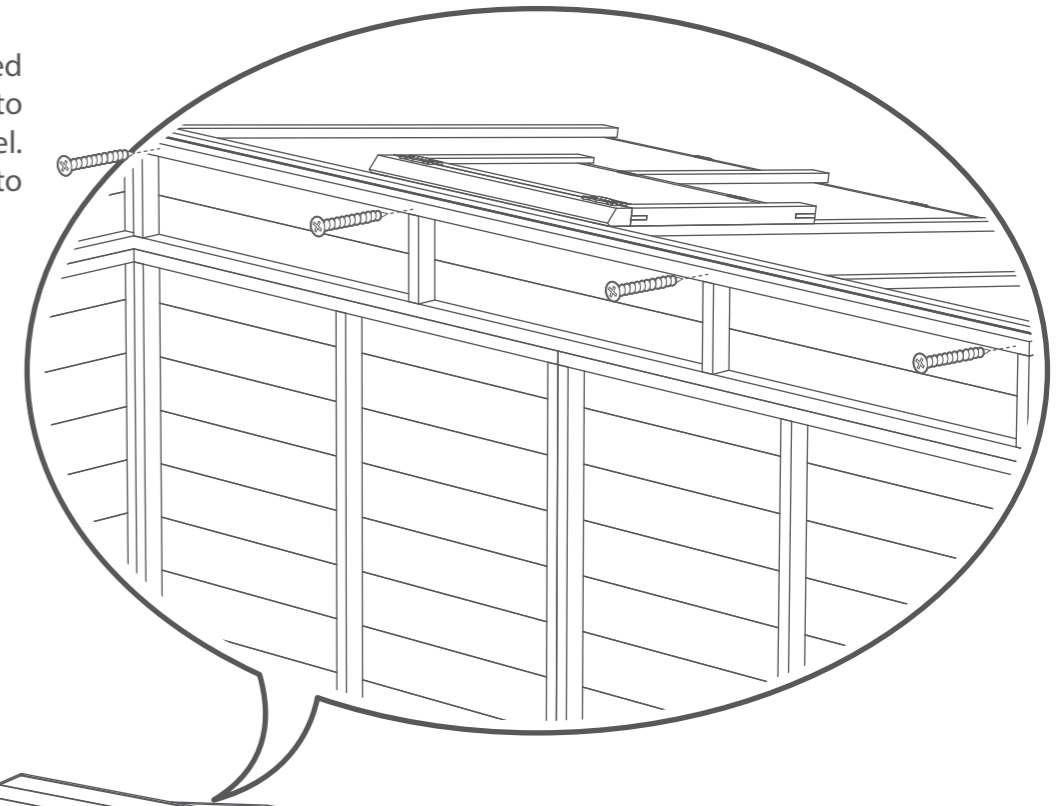

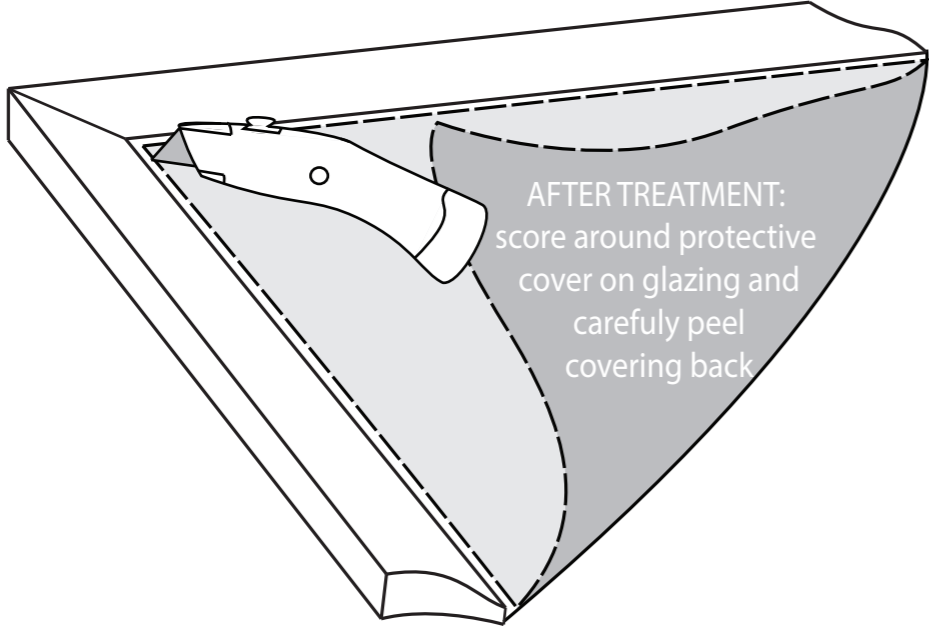

All our garden buildings have been designed and manufactured with care and attention to be the perfect addition to your outdoor space. To ensure you do get the best out of your new garden building and to increase the longevity we advise that you follow the product instructions and our manufacturer's recommendations as detailed below. Thank you for choosing a Mercia Garden product!

1 Choosing the most suitable location for your garden building...

A minimum of 60cm should be left around the perimeter of your garden building to allow access for maintenance, annual treatment and to allow air flow around the building.

Where possible you should avoid placing your garden building underneath large trees to prevent the tree causing damage to the building.

2 Preparing the base for your garden building...

All our buildings must be built on a firm, level base to ensure the longevity of the building and prevent the wood from distorting. We recommend either concrete, concrete slabs or a wooden base, such as our 'Portabase'.

The base should be slightly smaller than the external measurement of the building, i.e. the cladding should overlap the base, creating a run off for water and preventing water from pooling underneath the building.

We also recommend that the floor of the garden building is a minimum of 25mm above the surrounding ground level to avoid flooding.

3 After installation...

Once your garden building has been installed it will need to be treated as soon as possible and annually to prevent the timber from deteriorating and to waterproof it. This is required to maintain the anti-rot guarantee.

Dip Treated buildings - Require a preservative treatment to protect against rot and decay and a waterproof treatment to prevent water ingress

Pressure Treated buildings - Require a waterproof treatment to prevent water ingress

Log Cabins/Insulated Garden Rooms - Are supplied untreated and require a preservative and waterproofing treatment

We also recommend using a silicon sealant on the inside and outside of the windows as soon as possible after assembly and treatment to fully seal the windows.

Roofing felt/covering should be checked annually and replaced or fixed accordingly.

4 General maintenance and wood characteristics

As wood is a natural material it may be affected by the following:

Shrinkage and warping - The timber used in the construction of your garden building will have retained some of its natural moisture content. The moisture content of the timber will vary, depending upon prevailing environmental conditions, which will result in the components either naturally expanding or contracting. As the components dry out shrinkage may occur. A good waterproofing treatment from the start is the best protection to minimise the effect of moisture loss/intake.

In extended periods of very warm weather getting some moisture to the building will help the overall balance. You can do this by spraying it down lightly with a garden hose. In contrast after snow fall try to remove the snow as best as possible from the roof to prevent moisture intake and to remove the extra weight.

Top tip - using a garden brush will help you to reach the highest part of the building to remove snow and any debris left from bad weather.

Damp and mould - During the winter months, cold and damp conditions can result in an increased amount of moisture within your garden building, especially when used infrequently. Condensation can form on the timber and other items stored within your garden building. If left this moisture is likely to cause mould and mildew. To prevent the build-up of moisture, we recommend leaving the door or windows of your building open from time to time, to allow the fresh air to circulate. We also advise against storing wet or damp items in your garden building as this will also increase the level of moisture in the building. If mould or mildew does start to form within your building we recommend using an anti-mould cleaner to remove it and to prevent it spreading, which if left untreated could permanently damage your garden building.

Splits, cracks and knots - You may notice small splits and cracks in some components or holes may appear where knots shrink and fall out. This will not affect the structure of your Garden building however if you wish to fill them this can be easily done using any good quality wood filler.

Sap - is naturally occurring in wood and may appear in some boards of your garden building. If you wish to remove the sap, we advise waiting until it is dry and then using a sharp knife to carefully remove it. If the removal of the sap causes a hole in the timber, we recommend using a good quality wood filler to fill it.

For more handy hints and tips on how to care and maintain your garden building please refer to the MGP Customer Portal at www.mgplogistics.co.uk

Any further questions?

Contact our
Customer Service
Team on:
01636 821215

1 Manufacturer's Warranty

All Mercia Garden Products are supplied with a 1 year warranty on all parts against manufacturing defects.
This warranty does not cover movement, warping or splitting of timber products over time.

This warranty will be voided if any of the following occur:

1. The building has been customised or modified/adapted in any way.
2. The person claiming is not the original purchaser of the building.
3. Any damage has been caused by or as a result of misuse.
4. The building has not been maintained and cared for in accordance to our advisories and manufacturer's recommendations.
5. The building has not been treated annually or as per the manufacturer's recommendations, please ensure receipts are kept to validate this claim.
6. The building has not been erected, fitted or installed as per the supplier instructions.
7. The building has not been erected on a suitable sized firm flat, solid level concrete/slab base or placed on pressure treated bearers.
8. The building is or has been placed with 2 feet (60cm) of any obstructions (walls, trees, plants, fences etc.) which can allow moisture to penetrate the timber.
9. The roofing felt has been incorrectly fitted or damaged allowing water ingress, or not properly maintained.
10. Any windows and joints have not been sealed, inside and out, with silicone or other watertight sealant.
11. Any timber has been cut, pierced or drilled without subsequent application of approved cut-end treatment.

2 Anti-rot Guarantee

Mercia Garden Products offer a 10 year anti-rot guarantee on all dip treated (a preparatory treatment) and 15 years on all pressure treated products. This guarantee covers solid timber against rot, decay, blue stain and insect attack.

To validate the guarantee the building must be treated with a recognised wood preserver/water proof top coat (as detailed within manufacturer's recommendations) as soon as possible after assembly and annually thereafter.

This guarantee does not cover movement, warping or splitting of timber products over time.

This guarantee will be voided if any of the following occur:

1. The building has been customised or modified/adapted in any way.
2. The person claiming is not the original purchaser of the building.
3. Any damage is caused by or as a result of misuse.
4. The building has not been maintained and cared for in accordance to our advisories and manufacturer's recommendations.
5. The building has not been treated annually or as per the manufacturer's recommendations, please ensure receipts are kept to validate this claim.
6. The building has not been erected, fitted or installed as per the supplier instructions.
7. The building has not been erected on a suitable sized firm flat, solid level concrete/slab base or placed on pressure treated bearers.
8. The building is or has been placed with 2 feet (60cm) of any obstructions (walls, trees, plants, fences etc.) which can allow moisture to penetrate the timber.
9. The roofing felt has been incorrectly fitted or damaged allowing water ingress, or not properly maintained.
10. Any windows and joints have not been sealed, inside and out, with silicone or other watertight sealant.
11. Any timber has been cut, pierced or drilled without subsequent application of approved cut-end treatment.



REGISTER FOR YOUR
ANTI-ROT
GUARANTEE TODAY

PLEASE SCAN HERE:

