

04GREEN0406SD-V6

4x6 Greenhouse

BEFORE YOU START PLEASE READ INSTRUCTIONS CAREFULLY

- Check the pack and make sure you have all the parts listed.
- When you are ready to start, make sure you have the right tools at hand (not supplied) including a Phillips screwdriver, Stanley knife, Wood saw, Step ladder, Hammer and a Drill with 2mm bit.
- Ensure there is plenty of space and a clean dry area for assembly.

LOCATION FOR YOUR GARDEN BUILDING

A minimum of 60cm should be left around the perimeter of your garden building to allow access for maintenance, annual treatment and to allow air flow around the building.

Where possible you should avoid placing your garden building underneath large trees to prevent the tree causing damage to the building.

TIMBER

As with all natural materials, timber can be affected during various weather conditions. For the duration of heavy or extended periods of rain, swelling of the wood panels may occur. Warping of the wood may also occur during excessive dry spells due to an interior moisture loss. Unfortunately, these processes cannot be avoided but can be helped. It is suggested that the outdoor building is sprayed with water during extended periods of warm sunshine and sheltered as much as possible during rain or snow.

Once your garden building has been installed it will need to be treated as soon as possible and annually to prevent the timber from deteriorating and to waterproof it. This is required to maintain the anti-rot guarantee.

Dip Treated buildings - Require a preservative treatment to protect against rot and decay and a waterproof treatment to prevent water ingress

Pressure Treated buildings - Require a waterproof treatment to prevent water ingress

Log Cabins - Are supplied untreated and require a preservative and waterproofing treatment.

BUILDING A BASE

When thinking about where the building and base is going to be constructed: Ensure that there will be access to all sides for maintenance work and annual treatment.

Ensure the base is level and is built on firm ground, to prevent distortion. Refer to diagrams for the base dimensions, The base should be slightly smaller than the external measurement of the building, i.e. The cladding should overlap the base, creating a run off for water. It is also recommended that the floor be at least 25mm above the surrounding ground level to avoid flooding.

TYPES OF BASE

- Concrete 75mm laid on top of 75mm hard-core.
- Slabs laid on 50mm of sharp sand.

Whilst all products manufactured are made to the highest standards of Safety and in the case of childrens products independently tested to EN71 level, we cannot accept responsibility for your safety whilst erecting or using this product.



x2 All buildings should be erected by two adults



Winter = High Moisture = Expansion
Summer = Low Moisture = Contraction



2mm Drill bit

For ease of assembly, you **MUST** pilot drill all screw holes and ensure all screw heads are countersunk.



CAUTION

Every effort has been made during the manufacturing process to eliminate the prospect of splinters on rough surfaces of the timber. You are strongly advised to wear gloves when working with or handling rough sawn timber.



For ease of assembly, you will need a tape measure to check dimensions of components.

Screws & Nails



Measure overall length

Bolts



Measure under the head

To identify the fixings required for each step use a measuring tape.

****Protim Aquatan T5 (621)****

Your building has been dip treated with **Aquatan**.

Aquatan is a water-based concentrate which is diluted with water, the building as been treated by the correct application of Aquatan solution and then allowed to dry.

Aquatan is a decorative finish to colour the wood, which is applied industrially to timber fence panels and garden buildings.

Aquatan undiluted contains: boric acid, sodium hydroxide 32% solution, aqueous mixture of sodium dioctyl sulphosuccinat and alcohols: 2, 4, 6-trichlorophenol.



REGISTER FOR YOUR
ANTI-ROT
GUARANTEE TODAY

PLEASE SCAN HERE:



For assistance please contact customer care on: 01636 821215

Mercia Garden Products Limited,
Sutton On Trent,
Newark,
Nottinghamshire,
NG23 6QN

www.merciagardenproducts.co.uk



04GREEN0406SD-V6

Please retain product label and instructions for future reference

Overall Dimensions:

Width = 1215mm
Depth = 1887mm
Height = 2066mm

Base Dimensions:

Width = 1191mm
Depth = 1862mm

Before assembly
please make sure you have a
suitable base ready to erect your
building

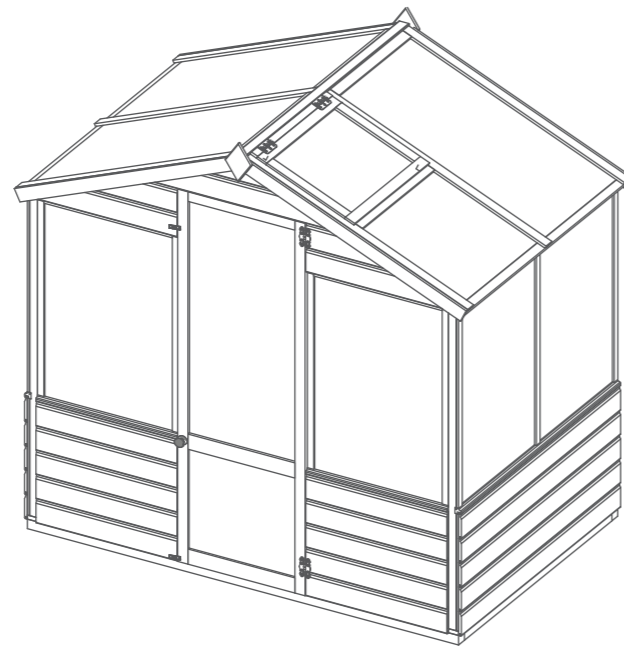

7

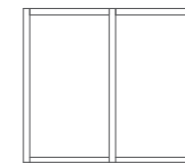

Roof

AI-04GREENROOF1218X1037-V1

8



Door

AI-04GREENDOOR550X1720-V5

9

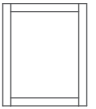

Opening Window

AI-04GREENOW560X460-V5

1

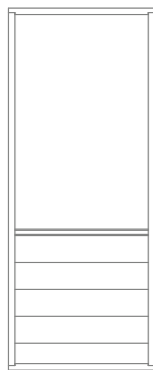

Door Side

AI-04GREENDS610X1543-V5
QTY 2

2

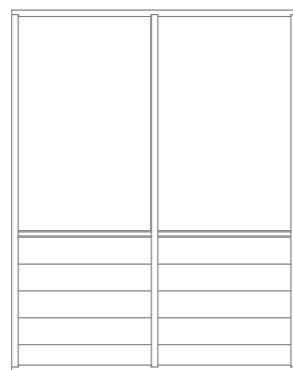

Sml Window Side

AI-04GREENWS1193X1543-V5
QTY 2

3

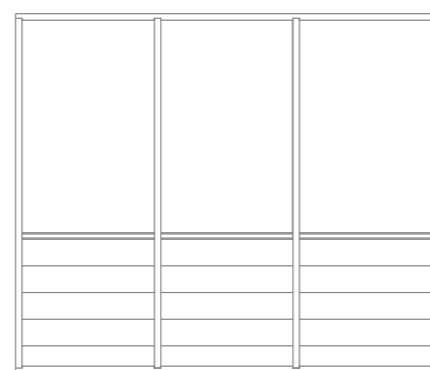

Lrg Window Side

AI-04GREENWS1776X1543-V5

4

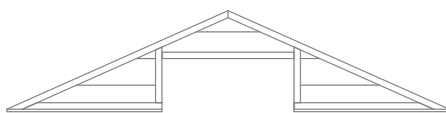

Door Gable Top

AI-04GREENDGT1864X426-V5

5

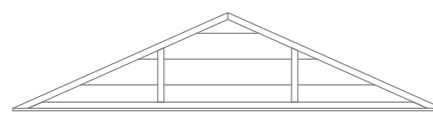

Plain Gable Top

AI-04GREENPGT1864X426-V5

6

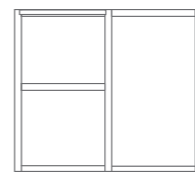

Roof (Opening Window)

AI-04GREENROOFOW1218X1037-V1

10

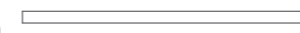

Fascia - 12x56x1075mm QTY 4
S1256-1075mm

11



Base Frame - 44x44x1864mm QTY 2
F4444-1864mm

12



Base Frame - 44x44x1105mm QTY 2
F4444-1105mm

13



Roof Support Bar 27x44x1242mm QTY 1
F2744-1242mm (8mm LIP, X2 66DEG CUTS)

14



Door Frame - 27x44x556mm QTY 1
F2744-556mm

15

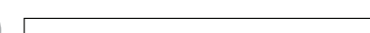

Door strip - 12x27x1717mm QTY 2
S1227-1717mm

16



Roof trim - 12x56x1242mm QTY 1
S1256-1242mm

17

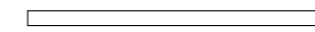

Short Door strip - 12x27x556mm QTY 1
S1227-556mm

18

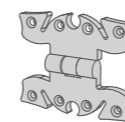

Butterfly Hinges QTY 4
PI-07-0004

19

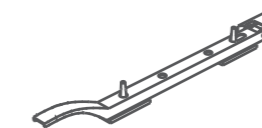

Window Casement Stay
PI-07-0008

20

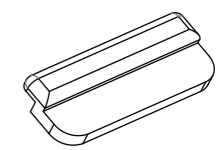

Window Glazing Bead QTY 8
PI-07-0063

21



Finial QTY 2
SHED DIAMOND FINIAL

22



Wooden Knob
PI-04-0024

23





Turn Button QTY 2
PI-07-0182

Nail Bag



24  **Window Strip - 12x27x926mm QTY 14**
S1227-926mm

25  **Window Strip - 12x27x1776mm**
S1227-1776mm

26  **Window Strip - 12x27x1193mm QTY 2**
S1227-1193mm

27  **Window Strip - 12x27x610mm QTY 2**
S1227-610mm

28  **Strip - 12x44x543mm**
S1244-543mm

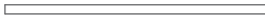
29  **Strip - 12x44x993mm QTY 6**
S1244-993mm

30  **Styrene 942x570x2mm QTY 9**
PI-05-0151

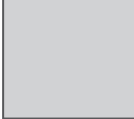
31  **Styrene 503x570mm**
PI-05-0158

32  **Styrene 985x570mm QTY 3**
PI-05-0157

33  **Strip - 12x44x1218mm QTY 2**
S1244-1218mm

34  **Window Cill 610mm QTY 2**
PI-08-0021

35  **Window Cill 1193mm QTY 2**
PI-08-0019

36  **Window Cill 1776mm**
PI-08-0020

37  **Strip - 12x21x560mm**
S1221-560mm

38  **Corner Trims - 12x56x1576mm QTY 4**
S1256-1576mm

Pre Assembly

Before assembling remove the transportation blocks from the bottom of each panel.

Step 1

Lay the base frame down as shown in the diagram. Ensure the base is square and layed on level ground. Fix the base framing (**No. 11**) & (**No. 12**) together with 2 x 70mm screws per corner, pre drill to avoid splitting the timber.

8x70mm screws.

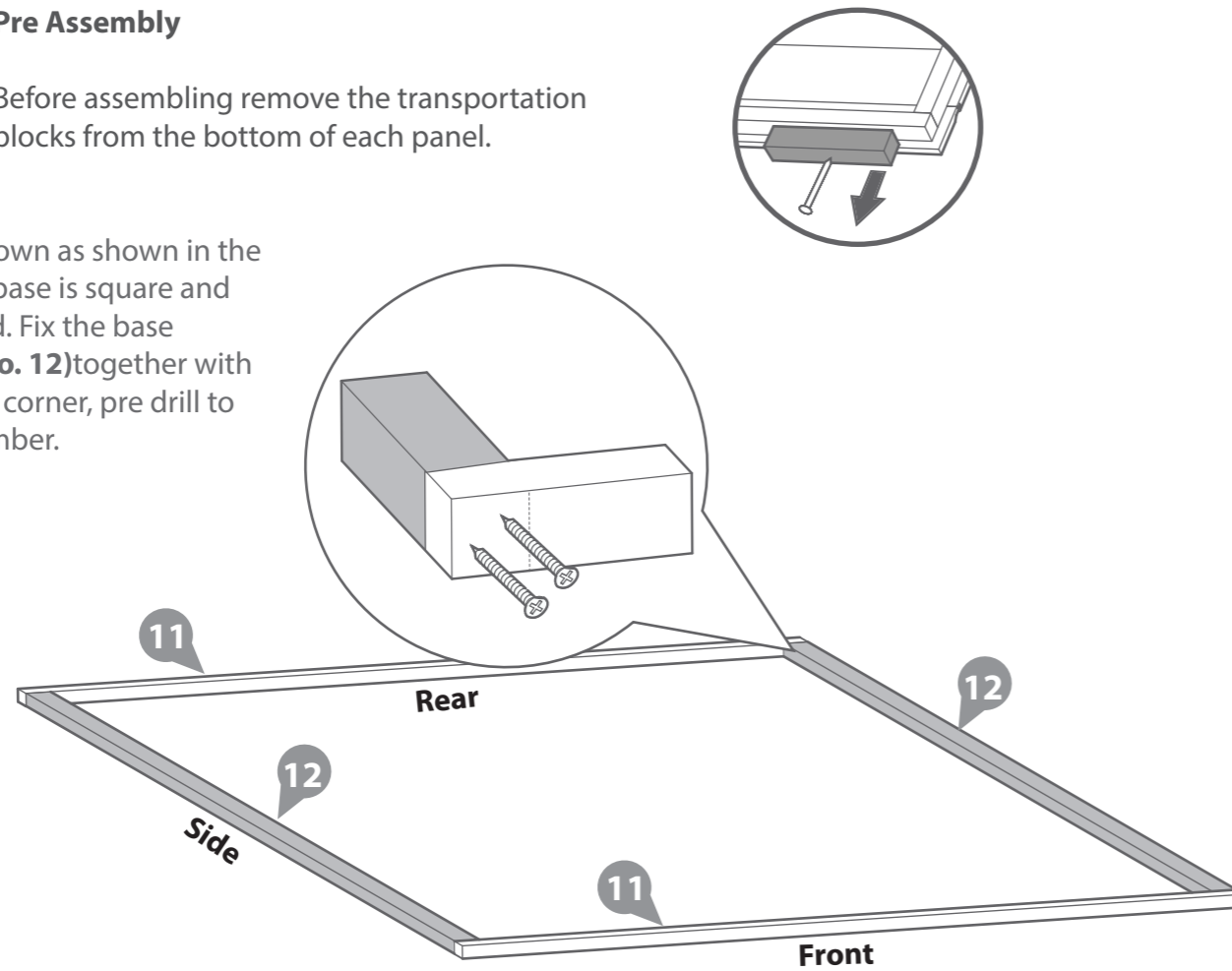

Step 2

Assemble the window panels on the floor.

Place the plastic window cill onto the lip of the window panel externally.

1b. Lay the styrene on top of each opening so that it overlaps the surrounding framing equally on both sides as per the diagram.

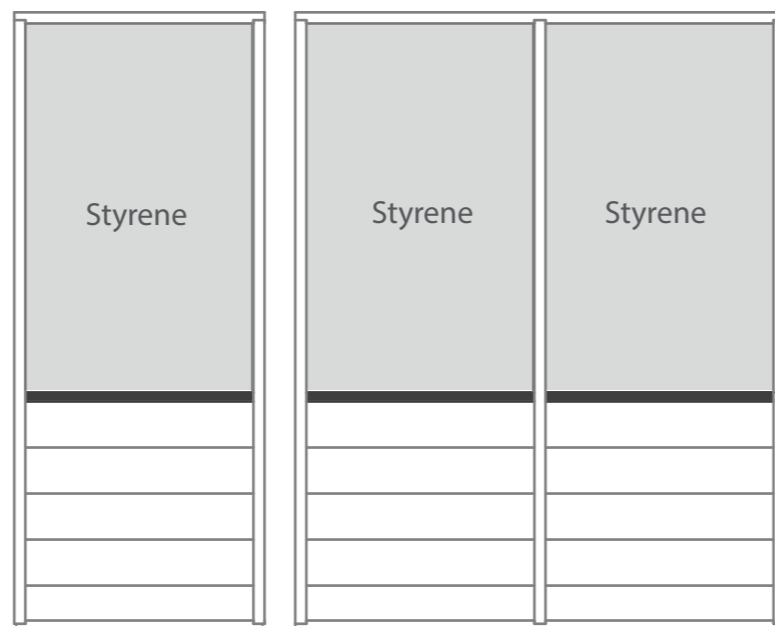
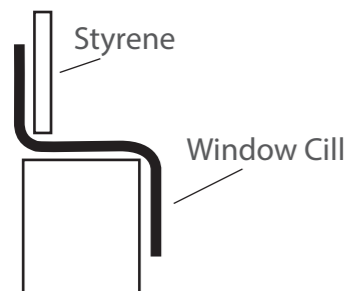

Step 3

Attach the window strips using 3x30mm screws as per the diagram, starting with the top strip. Ensure the framing does not protrude the width of the window frame.

Ensure you screw into the window strips to the side of where the styrene meets the window frame.

81x30mm

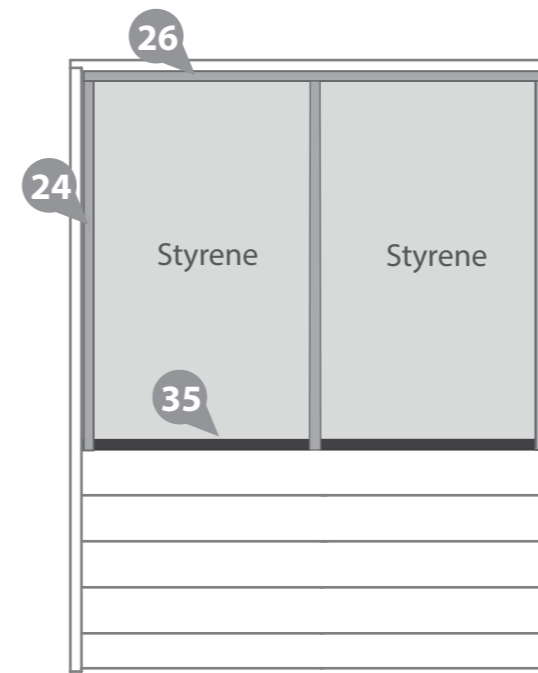
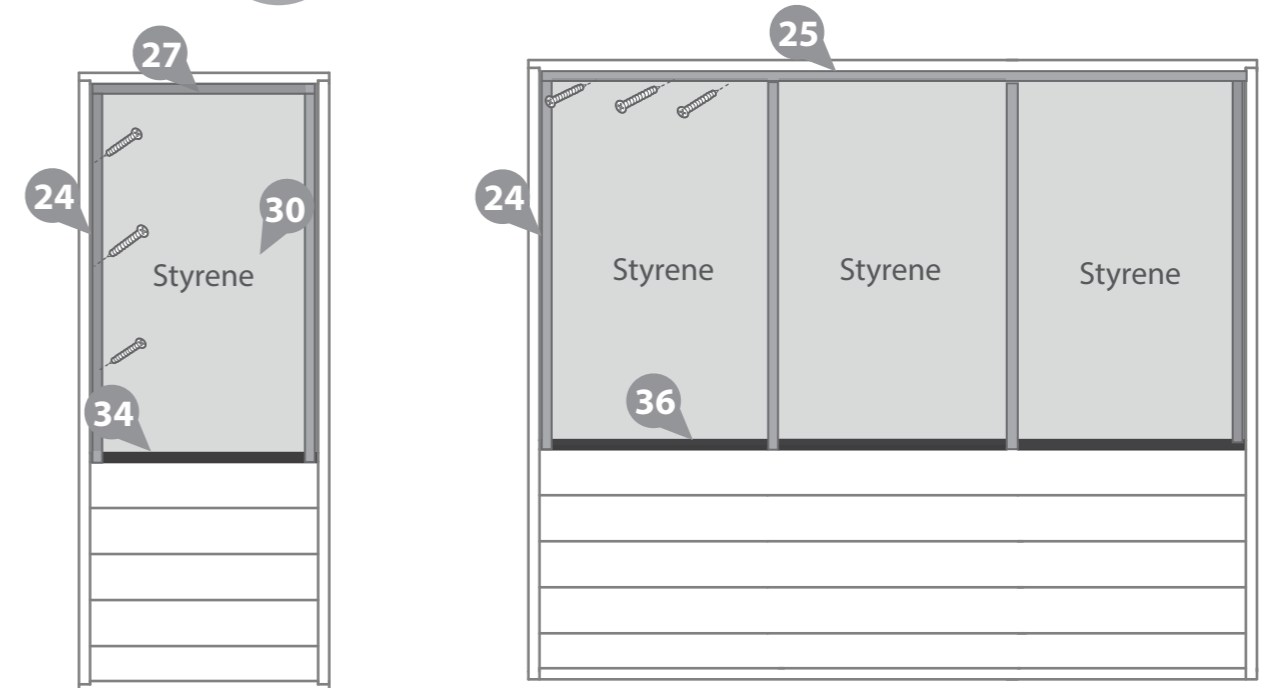

Step 4

Fix the corners of the Sml Window Side (**No. 2**) and the Lrg Window Side (**No. 3**) with 3x50mm screws as shown in the diagram.

The large window side sits inbetween the two side panels.

3x50mm screws.

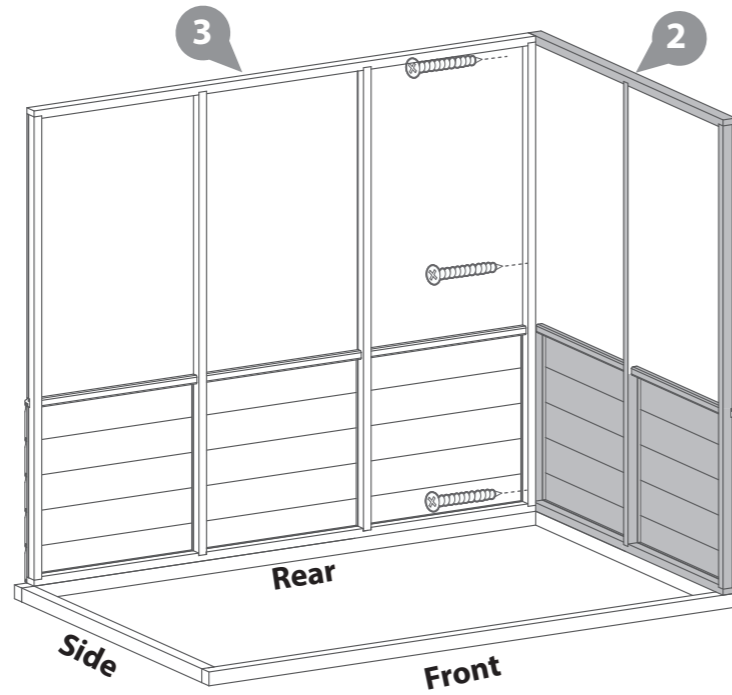

Step 6

Fix the Door Sides (**No. 1**) between the window panels using 6x50mm screws.

6x50mm Screws.

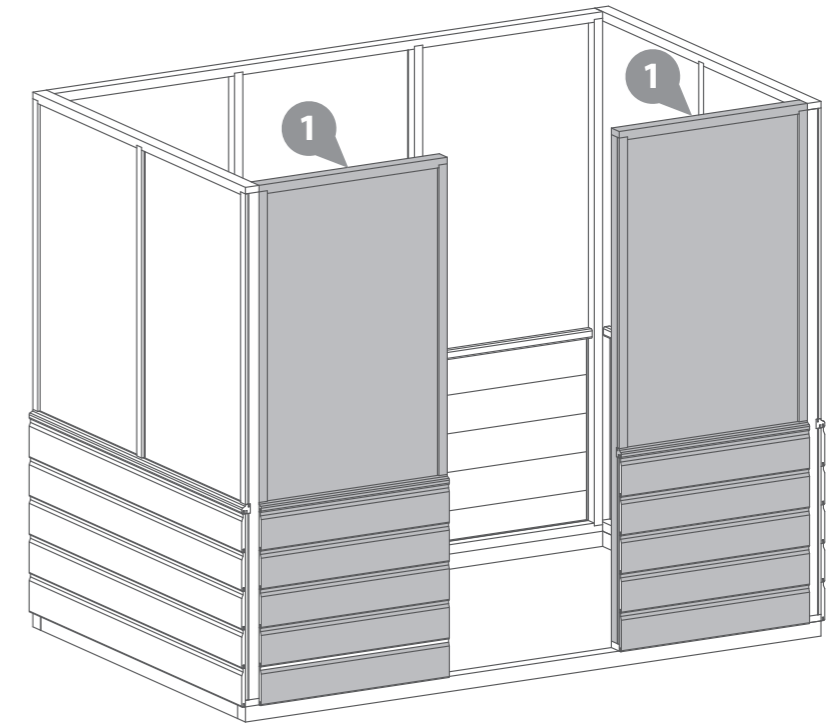

Step 5

Fix the remaining Sml Window Side (**No. 2**) at the corner using 3 x 50mm screws.

3x50mm screws.

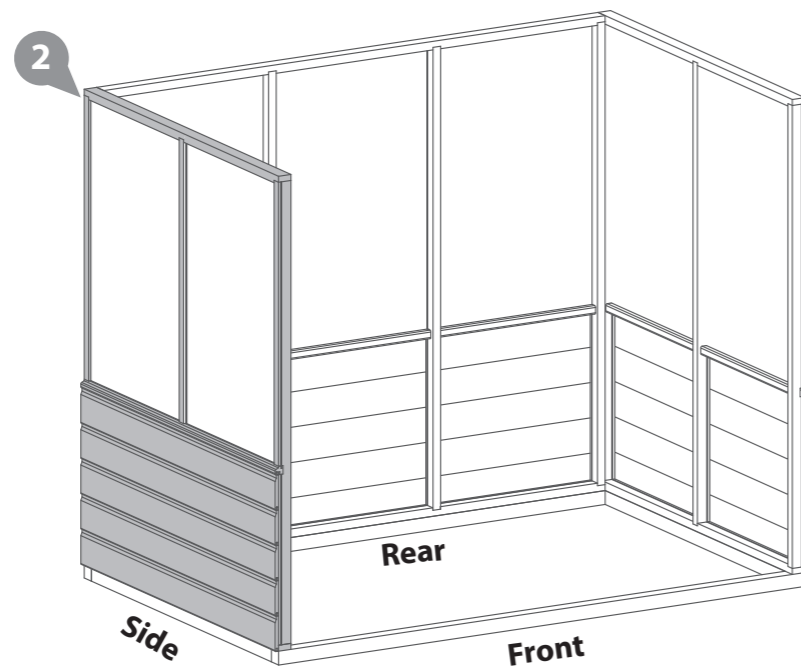

Step 7

Fix the Door frame (**No. 14**) to the base frame between the Door sides. This allows for the door sides to be correctly spaced.

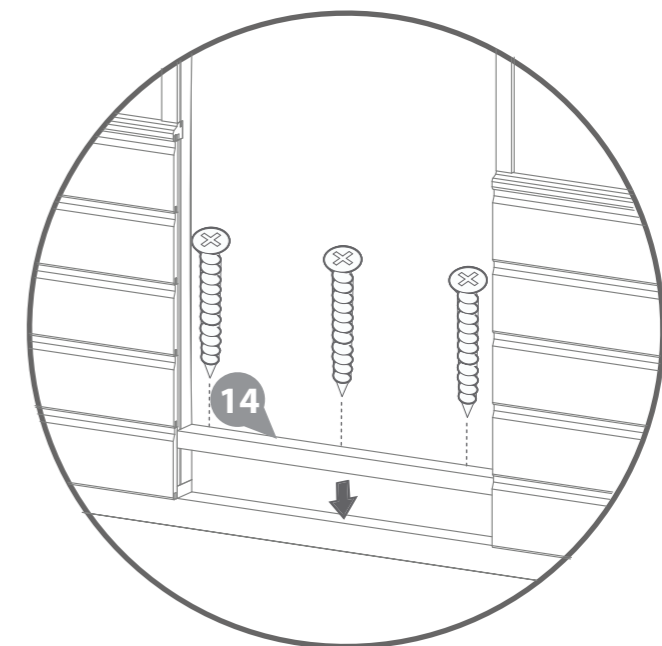

Step 8

Fix the Gable tops (**No. 4**) & (**No. 5**) to the panels using 4x50mm screws per top as shown in the diagram.

8x50mm Screws.

The building can now be attached to the floor framing with 6x50mm screws per side.

24x50mm Screws.

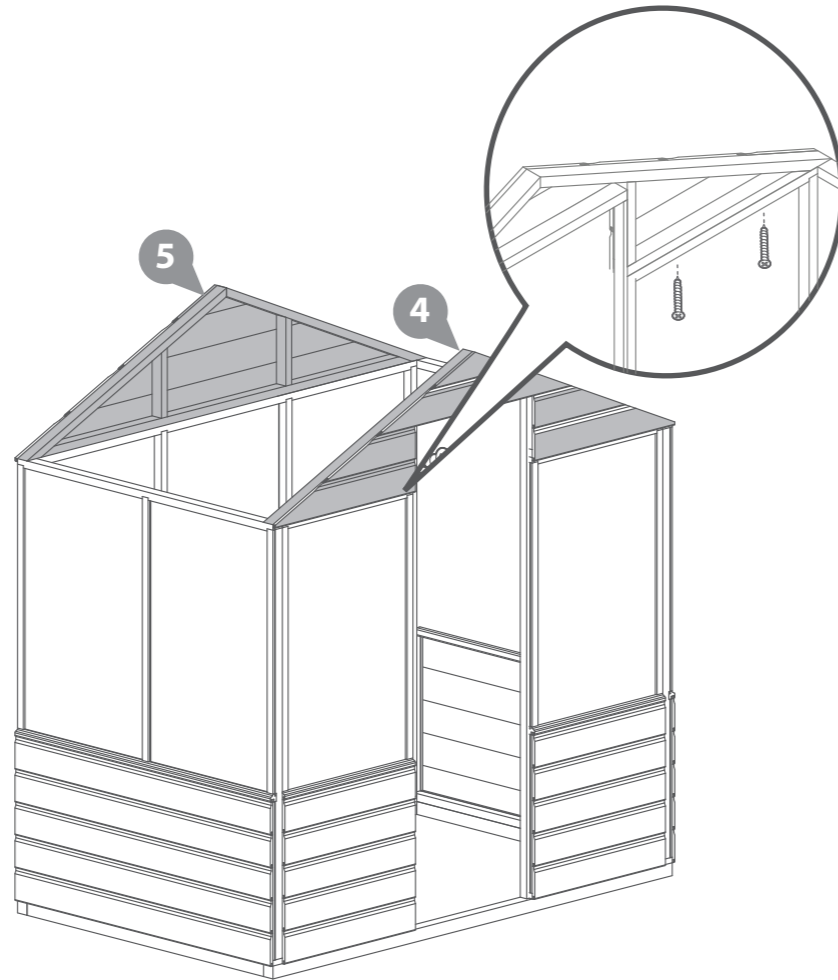

Step 9

Fix the two Door strips (**No. 15**) to either side of the door panels with 3x30mm screws per strip.

6x30mm Screws.

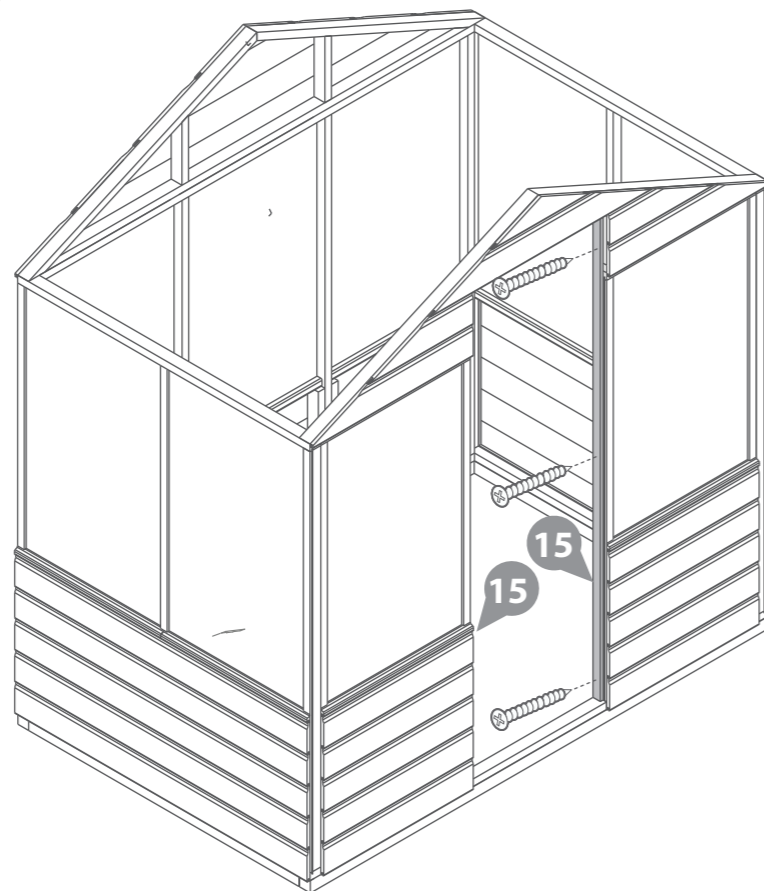

Step 10

Fix the Door strip (**No. 17**) to the top of the door opening with 3x30mm screws.

3x30mm Screws.

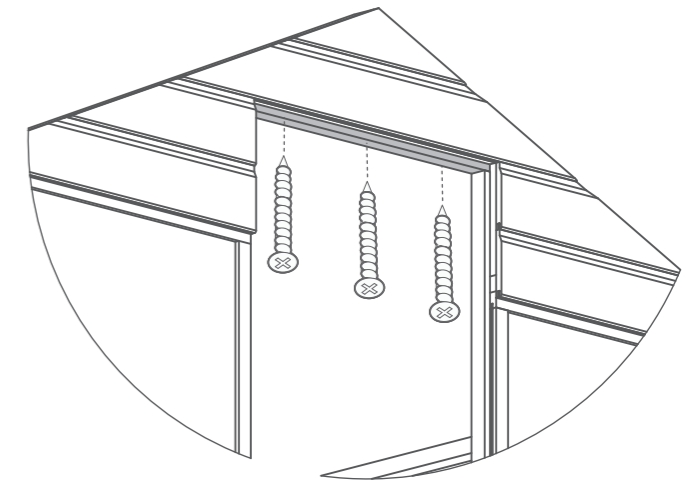
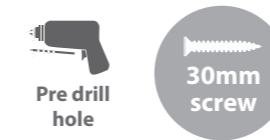

Step 11

Lay the roof panel down (**No. 6**) and place the styrene sheets (**No. 30, 32**) in position using the beads (**No. 20**) which will be screwed down with 2x16mm screws. Ensure the thinner edge of the frame is facing the bottom.

8x16mm Screws.

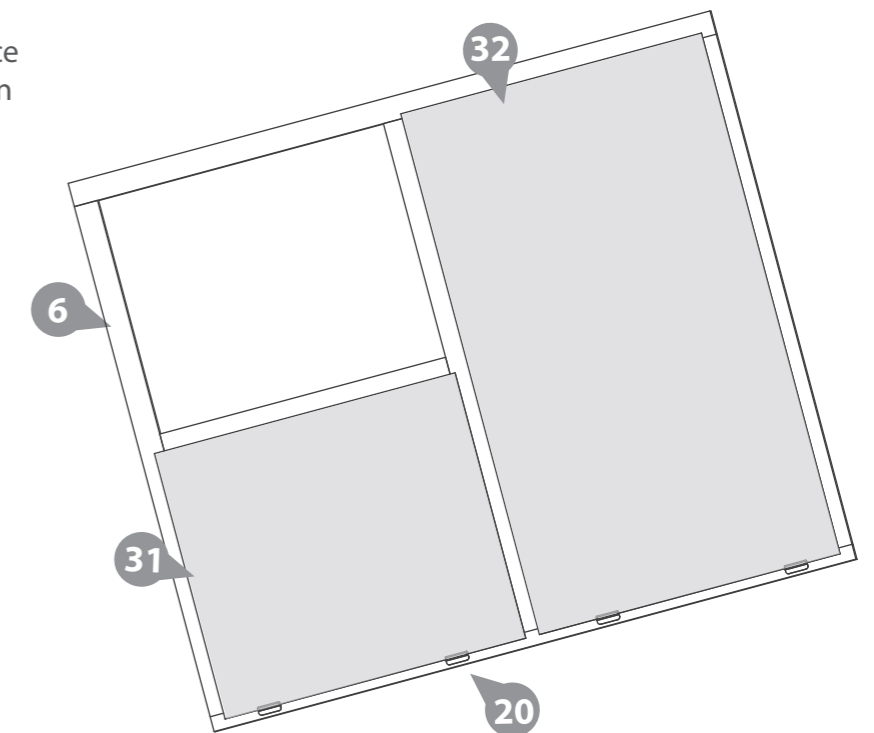

Step 12

Fix the strips (No 28, 29, 33) onto the window frame using 3x30mm screws per strip. Ensure you screw to the side of the styrene not through it.

15x30mm Screws.



Pre drill hole



30mm screw

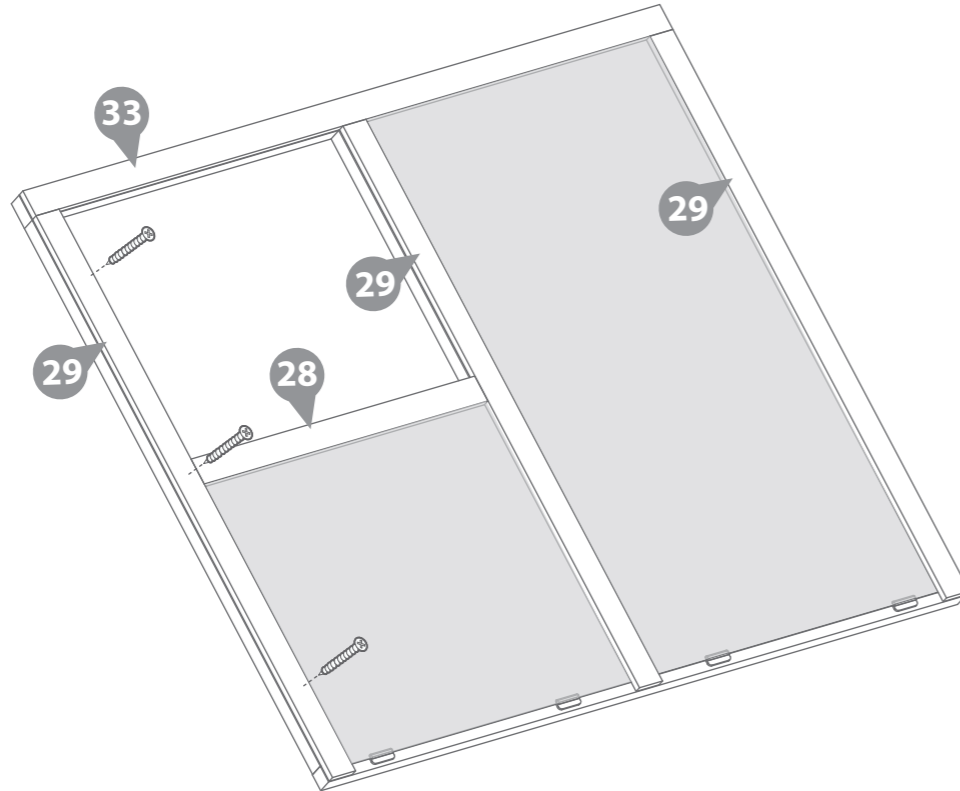

Step 13

Attach the strip (No.37) onto the window panel with 4x30mm screws. Drop the window (No.9) into the aperture and attach the window on the roof panel (No.6) using 4x16 screws and 4x30mm screws per hinge.

8x30mm Screws.
4x16mm Screws.



8x30mm screw



4x16mm screw

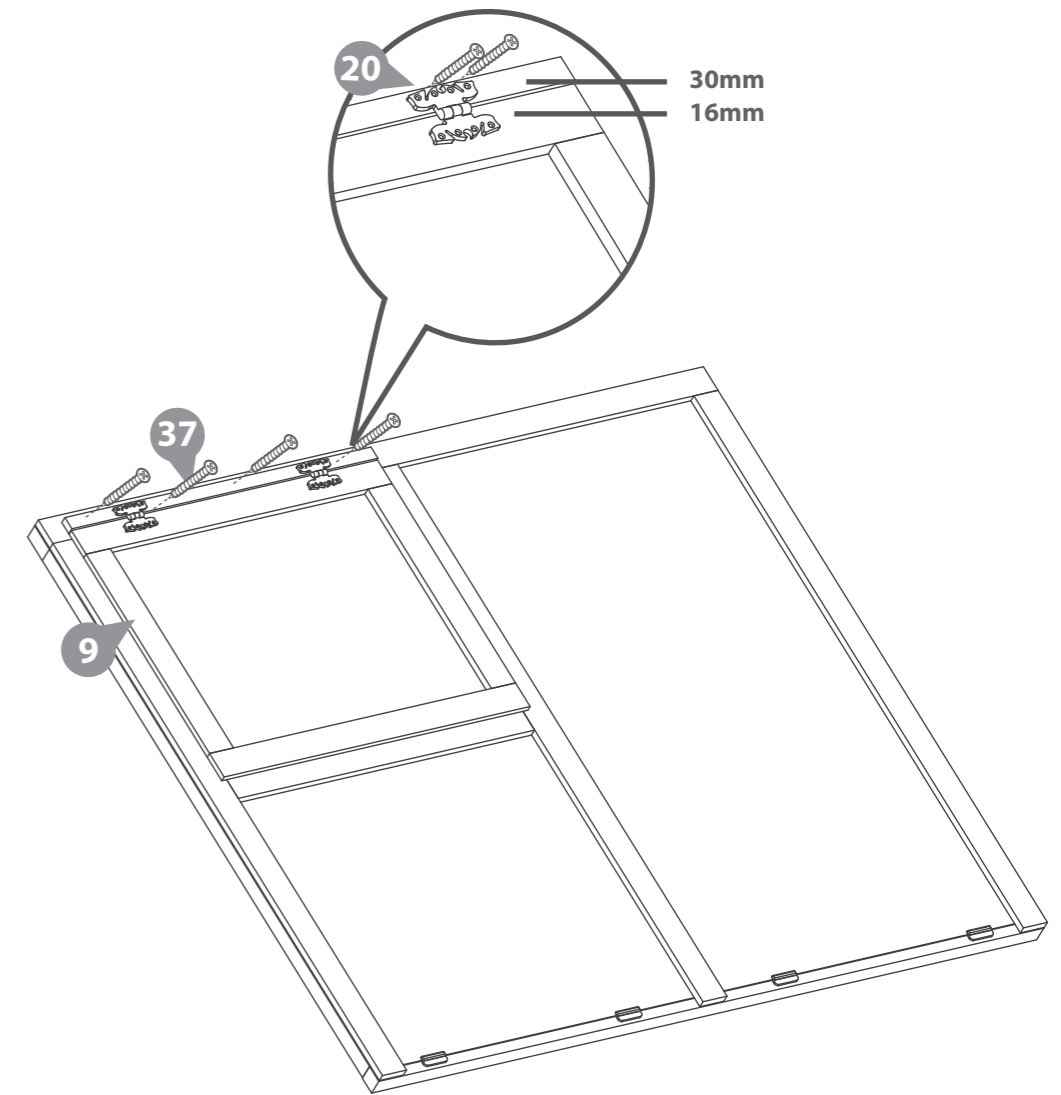

Step 14

Repeat step 12 for part 7.

12x30mm Screws.

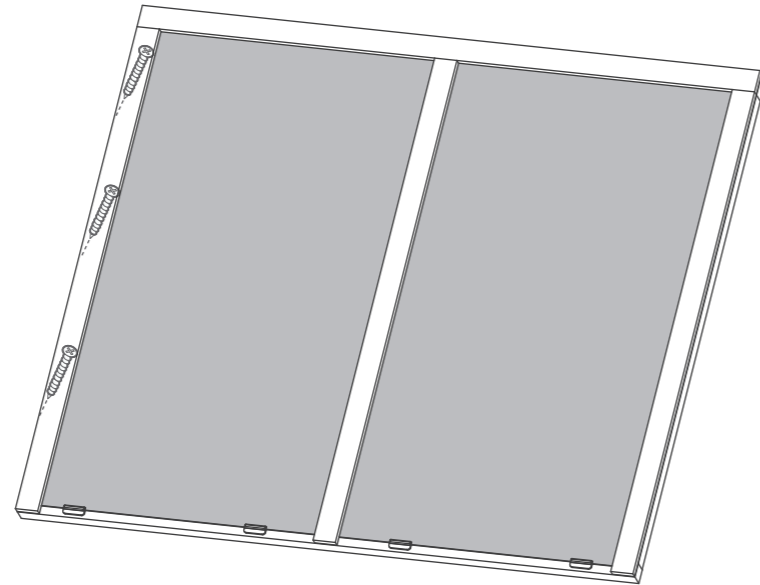

Step 15

Place the Roof panels (No. 6) & (No. 7) on top of each gable, making sure the roofs are flush to each gable and meet at the top of the apex.

Secure each roof panel to the building using 16x50mm screws.

16x50mm Screws.

***IMPORTANT** Ensure both roof sections meet at the top of the apex as shown in the illustration.

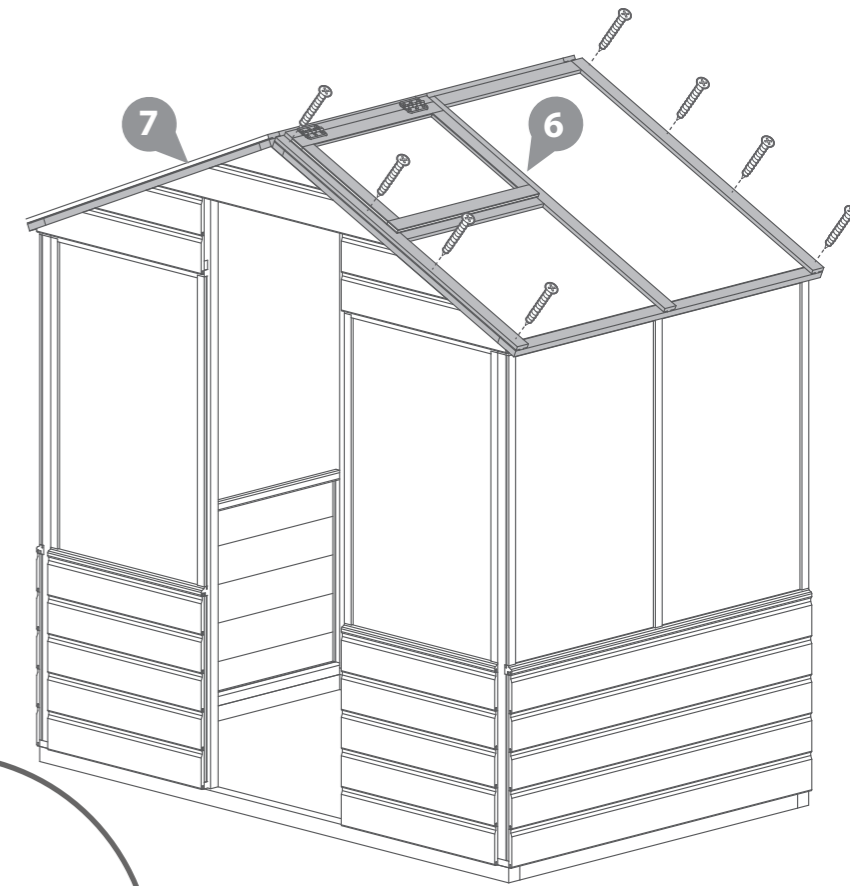
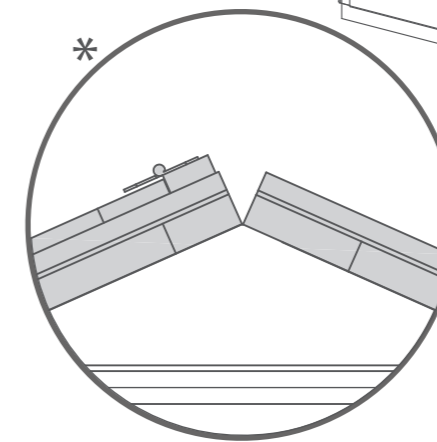

Step 16

Fix the Casement stay (No. 19) to the opening window then align the fixings onto the window panel frame. Ensure the casement stay fits onto fixings when closed before screwing them down using 6x20mm screws.

6x20mm Screws.

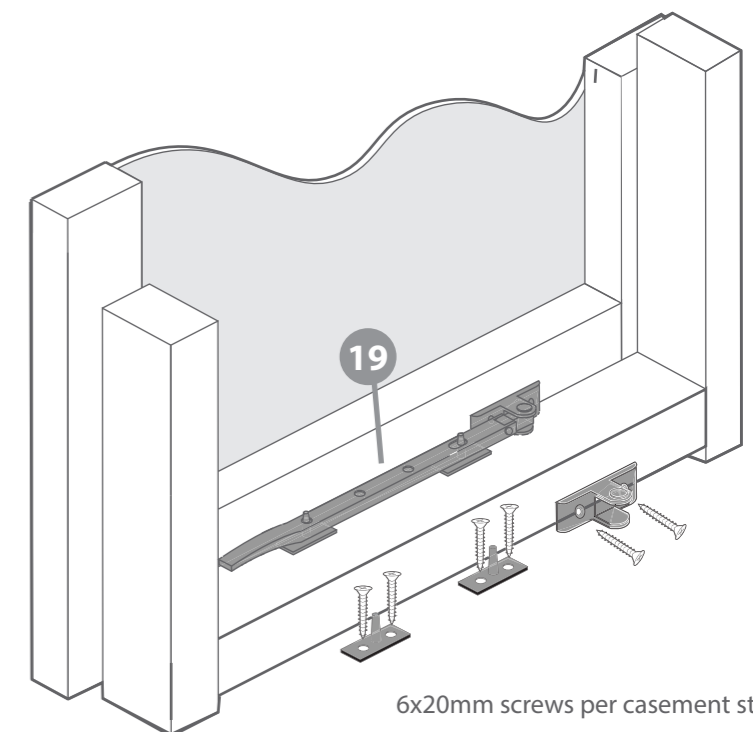
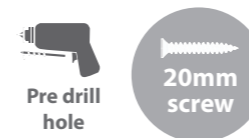

6x20mm screws per casement stay

Step 17

Attach the Roof Support bar (**No. 13**) to the roof panels using 5x40mm screws.

Screw diagonally through the support into the roof panel as shown in the diagram.

5x40mm Screws.

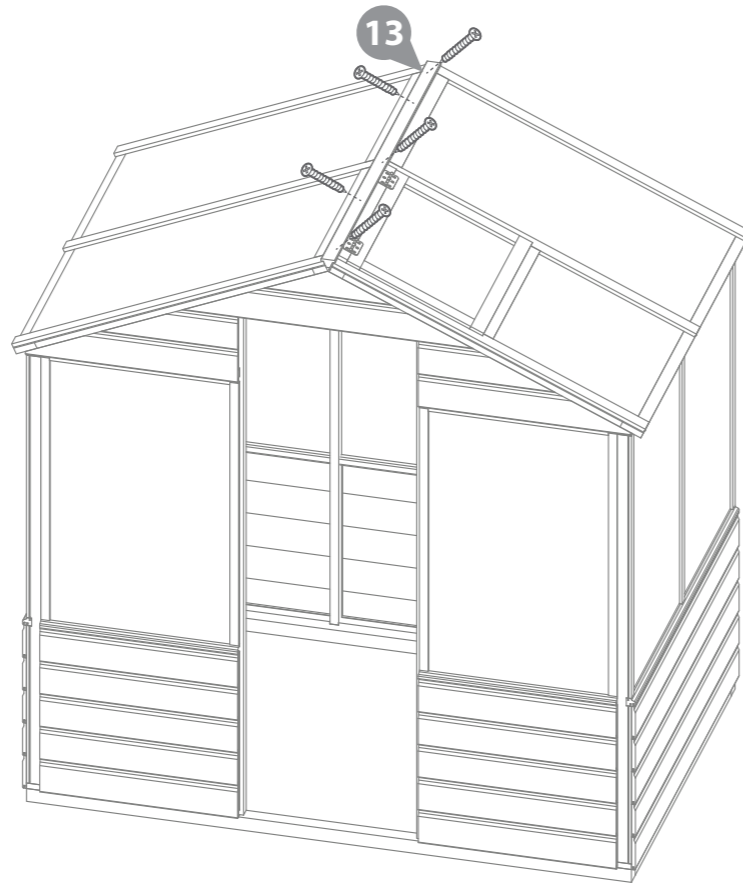

Step 19

Fix the building to the base with 50mm screws evenly spaced as shown.

10x50mm Screws.

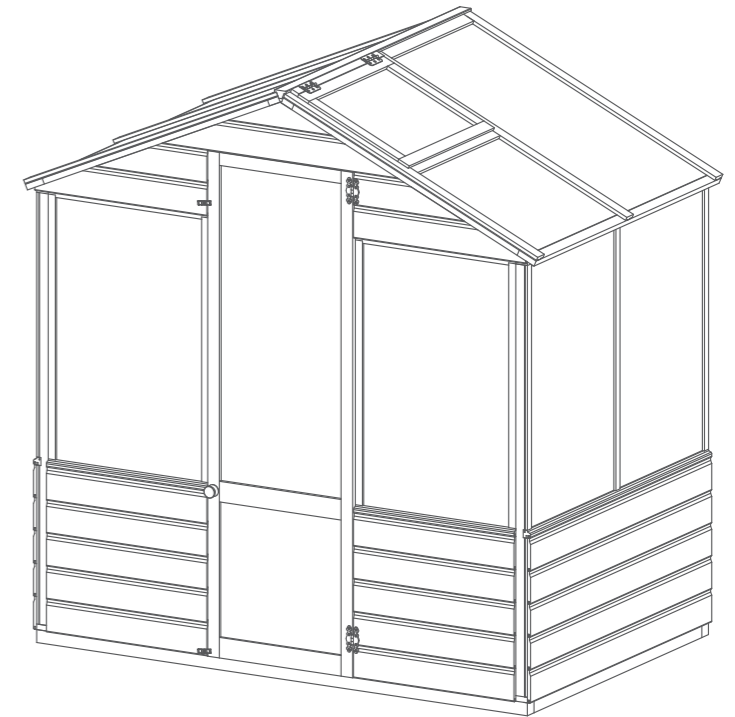
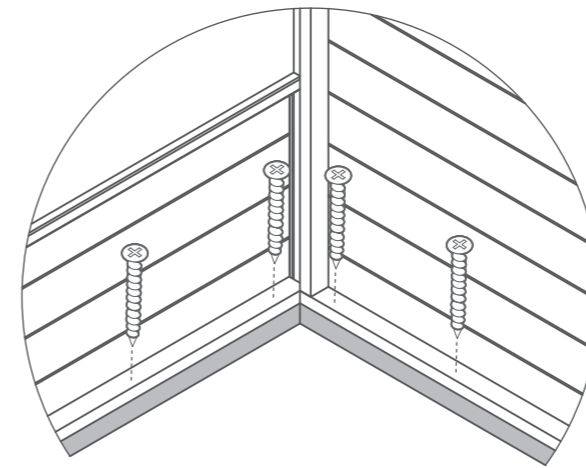

Step 18

Fix the door (**No. 8**) to the building using 16x30mm black screws per hinge (**No. 18**) as shown in the diagram.

16x30mm Black Screws.

Fit the turn buttons (**No. 23**) to the building using 2x30mm black screws.

2x30mm Black Screws.

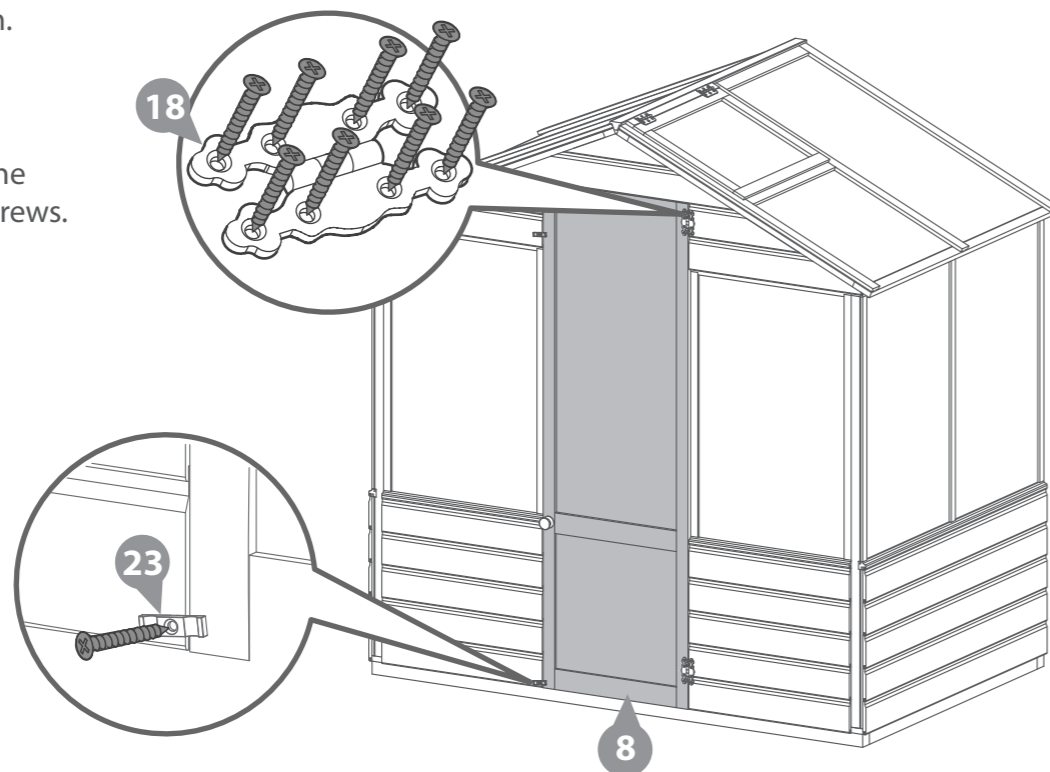

Step 20

Fix the corner trims (**No.38**) in position using 4x30mm screws

16x30mm Screws

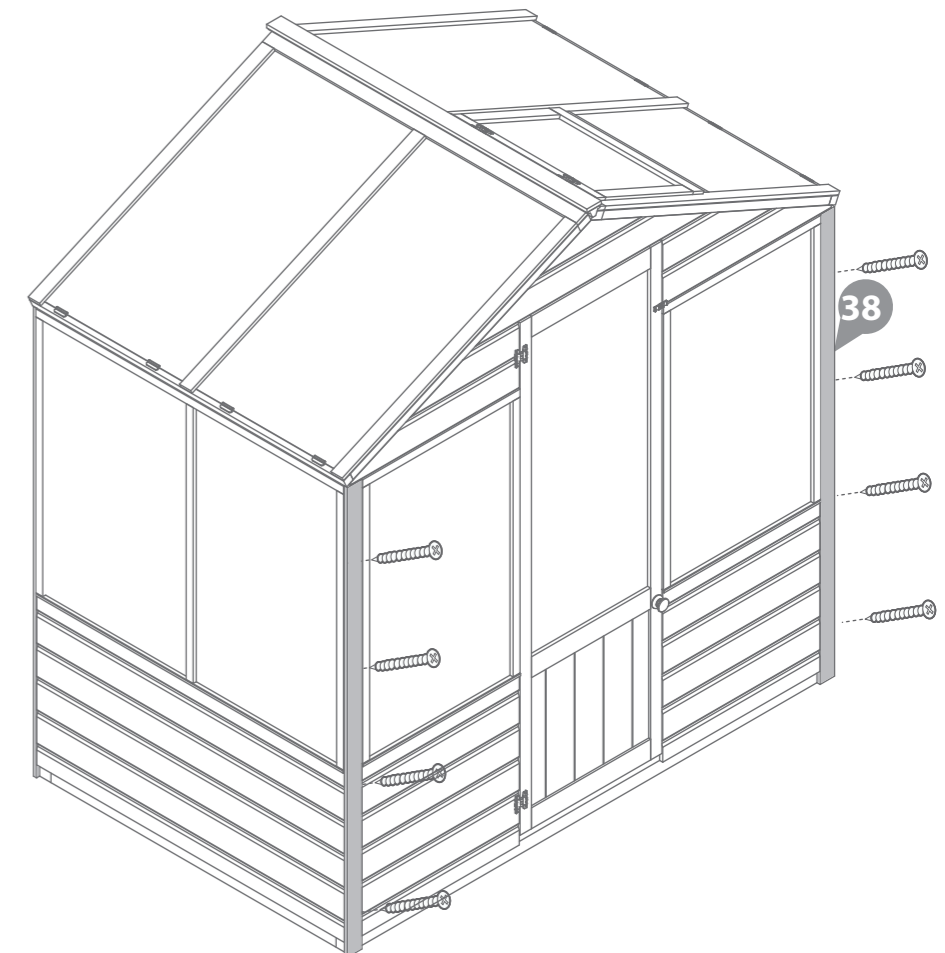

Step 21

Fit the fascias (No. 10) and the finials (No. 21) to the building using 14x30mm screws as shown in the diagram.

14x30mm Screws

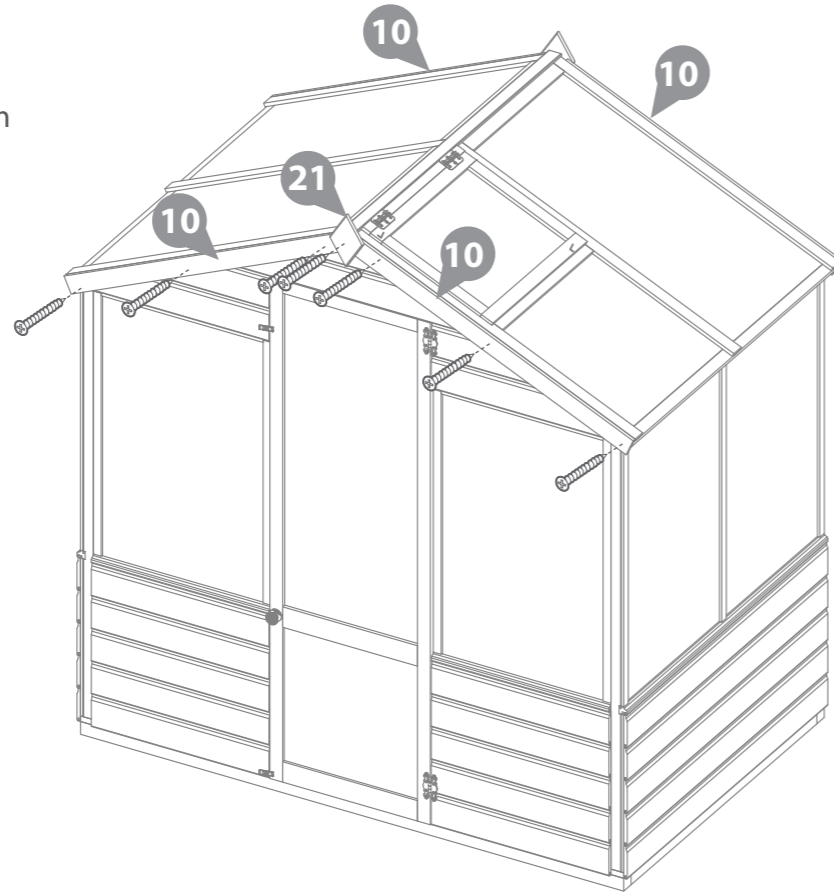

Step 22

Fix the Roof trim (No. 16) to the top of the building and secure with 4x30mm screws as shown.

4x30mm Screws

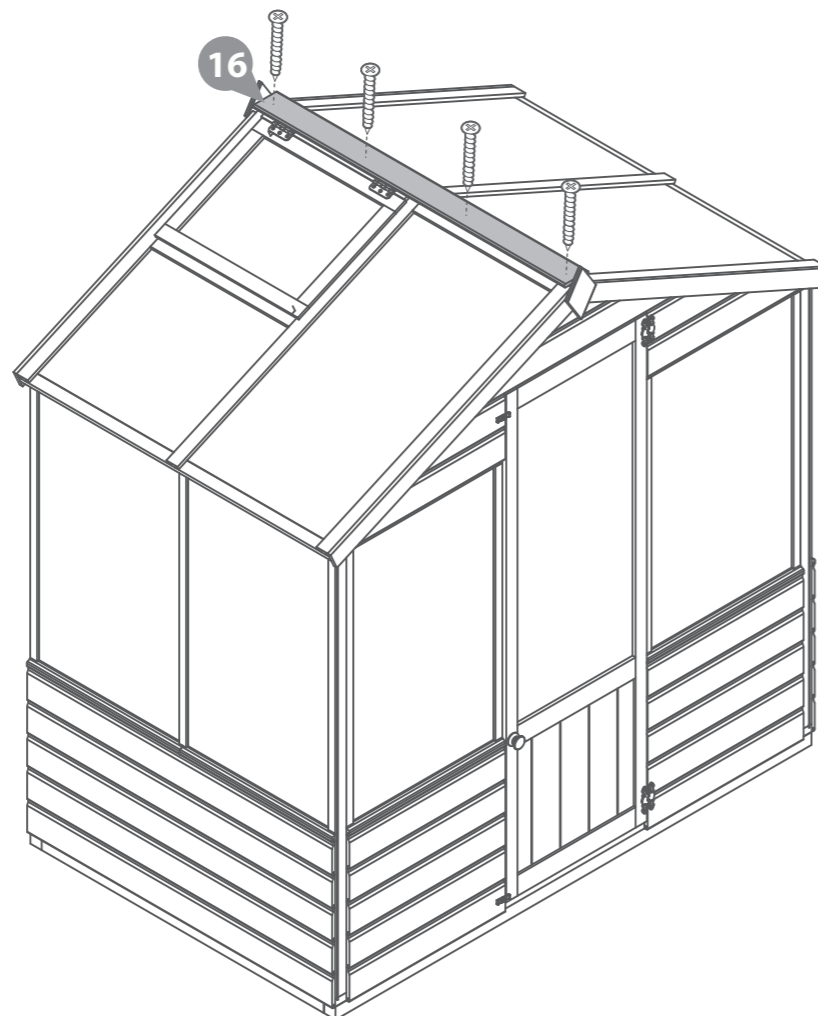

Step 23

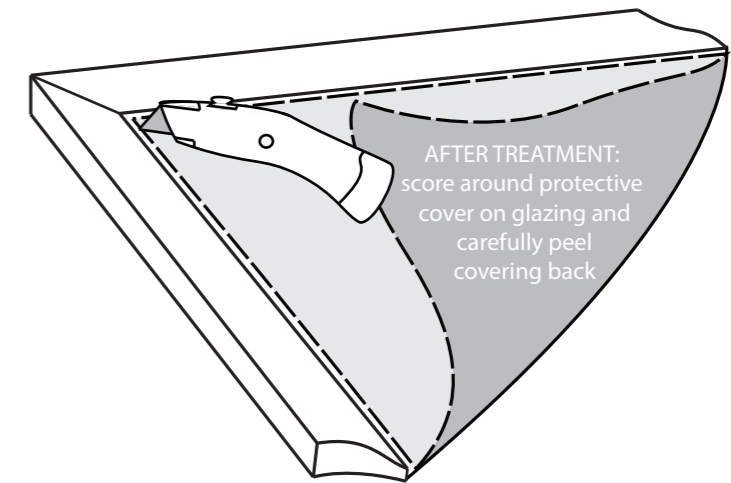

Step 23

It is **ESSENTIAL** to seal around all window framing with silicone sealant (**not included**) to minimise water ingress.

**Please note: This image is for illustrative purposes and may differ from your product (in regards to the number of windows) however the principle is the same.*

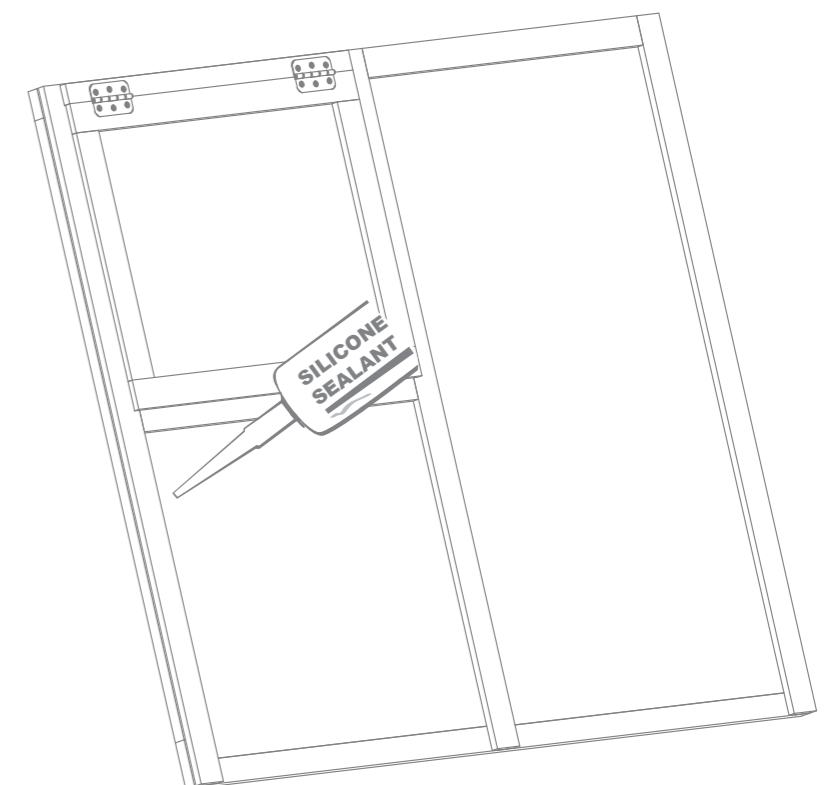

All our garden buildings have been designed and manufactured with care and attention to be the perfect addition to your outdoor space. To ensure you do get the best out of your new garden building and to increase the longevity we advise that you follow the product instructions and our manufacturer's recommendations as detailed below. Thank you for choosing a Mercia Garden product!

1 Choosing the most suitable location for your garden building...

A minimum of 60cm should be left around the perimeter of your garden building to allow access for maintenance, annual treatment and to allow air flow around the building.

Where possible you should avoid placing your garden building underneath large trees to prevent the tree causing damage to the building.

2 Preparing the base for your garden building...

All our buildings must be built on a firm, level base to ensure the longevity of the building and prevent the wood from distorting. We recommend either concrete, concrete slabs or a wooden base, such as our 'Portabase'.

The base should be slightly smaller than the external measurement of the building, i.e. the cladding should overlap the base, creating a run off for water and preventing water from pooling underneath the building.

We also recommend that the floor of the garden building is a minimum of 25mm above the surrounding ground level to avoid flooding.

3 After installation...

Once your garden building has been installed it will need to be treated as soon as possible and annually to prevent the timber from deteriorating and to waterproof it. This is required to maintain the anti-rot guarantee.

Dip Treated buildings - Require a preservative treatment to protect against rot and decay and a waterproof treatment to prevent water ingress

Pressure Treated buildings - Require a waterproof treatment to prevent water ingress

Log Cabins/Insulated Garden Rooms - Are supplied untreated and require a preservative and waterproofing treatment

We also recommend using a silicon sealant on the inside and outside of the windows as soon as possible after assembly and treatment to fully seal the windows.

Roofing felt/covering should be checked annually and replaced or fixed accordingly.

4 General maintenance and wood characteristics

As wood is a natural material it may be affected by the following:

Shrinkage and warping - The timber used in the construction of your garden building will have retained some of its natural moisture content. The moisture content of the timber will vary, depending upon prevailing environmental conditions, which will result in the components either naturally expanding or contracting. As the components dry out shrinkage may occur. A good waterproofing treatment from the start is the best protection to minimise the effect of moisture loss/intake.

In extended periods of very warm weather getting some moisture to the building will help the overall balance. You can do this by spraying it down lightly with a garden hose. In contrast after snow fall try to remove the snow as best as possible from the roof to prevent moisture intake and to remove the extra weight.

Top tip - using a garden brush will help you to reach the highest part of the building to remove snow and any debris left from bad weather.

Damp and mould - During the winter months, cold and damp conditions can result in an increased amount of moisture within your garden building, especially when used infrequently. Condensation can form on the timber and other items stored within your garden building. If left this moisture is likely to cause mould and mildew. To prevent the build-up of moisture, we recommend leaving the door or windows of your building open from time to time, to allow the fresh air to circulate. We also advise against storing wet or damp items in your garden building as this will also increase the level of moisture in the building. If mould or mildew does start to form within your building we recommend using an anti-mould cleaner to remove it and to prevent it spreading, which if left untreated could permanently damage your garden building.

Splits, cracks and knots - You may notice small splits and cracks in some components or holes may appear where knots shrink and fall out. This will not affect the structure of your Garden building however if you wish to fill them this can be easily done using any good quality wood filler.

Sap - is naturally occurring in wood and may appear in some boards of your garden building. If you wish to remove the sap, we advise waiting until it is dry and then using a sharp knife to carefully remove it. If the removal of the sap causes a hole in the timber, we recommend using a good quality wood filler to fill it.

For more handy hints and tips on how to care and maintain your garden building please refer to the MGP Customer Portal at www.mgplogistics.co.uk

Any further questions?

Contact our
Customer Service
Team on:
01636 821215

1 Manufacturer's Warranty

All Mercia Garden Products are supplied with a 1 year warranty on all parts against manufacturing defects.
This warranty does not cover movement, warping or splitting of timber products over time.

This warranty will be voided if any of the following occur:

1. The building has been customised or modified/adapted in any way.
2. The person claiming is not the original purchaser of the building.
3. Any damage has been caused by or as a result of misuse.
4. The building has not been maintained and cared for in accordance to our advisories and manufacturer's recommendations.
5. The building has not been treated annually or as per the manufacturer's recommendations, please ensure receipts are kept to validate this claim.
6. The building has not been erected, fitted or installed as per the supplier instructions.
7. The building has not been erected on a suitable sized firm flat, solid level concrete/slab base or placed on pressure treated bearers.
8. The building is or has been placed with 2 feet (60cm) of any obstructions (walls, trees, plants, fences etc.) which can allow moisture to penetrate the timber.
9. The roofing felt has been incorrectly fitted or damaged allowing water ingress, or not properly maintained.
10. Any windows and joints have not been sealed, inside and out, with silicone or other watertight sealant.
11. Any timber has been cut, pierced or drilled without subsequent application of approved cut-end treatment.



REGISTER FOR YOUR
ANTI-ROT
GUARANTEE TODAY

PLEASE SCAN HERE:



2 Anti-rot Guarantee

Mercia Garden Products offer a 10 year anti-rot guarantee on all dip treated (a preparatory treatment) and 15 years on all pressure treated products. This guarantee covers solid timber against rot, decay, blue stain and insect attack.

To validate the guarantee the building must be treated with a recognised wood preserver/water proof top coat (as detailed within manufacturer's recommendations) as soon as possible after assembly and annually thereafter.

This guarantee does not cover movement, warping or splitting of timber products over time.

This guarantee will be voided if any of the following occur:

1. The building has been customised or modified/adapted in any way.
2. The person claiming is not the original purchaser of the building.
3. Any damage is caused by or as a result of misuse.
4. The building has not been maintained and cared for in accordance to our advisories and manufacturer's recommendations.
5. The building has not been treated annually or as per the manufacturer's recommendations, please ensure receipts are kept to validate this claim.
6. The building has not been erected, fitted or installed as per the supplier instructions.
7. The building has not been erected on a suitable sized firm flat, solid level concrete/slab base or placed on pressure treated bearers.
8. The building is or has been placed with 2 feet (60cm) of any obstructions (walls, trees, plants, fences etc.) which can allow moisture to penetrate the timber.
9. The roofing felt has been incorrectly fitted or damaged allowing water ingress, or not properly maintained.
10. Any windows and joints have not been sealed, inside and out, with silicone or other watertight sealant.
11. Any timber has been cut, pierced or drilled without subsequent application of approved cut-end treatment.