

05DTMBAX0307DD-V1

DIP TREATED MATCHBOARD APEX 3X7 DOUBLE DOOR BIKE STORAGE

BEFORE YOU START PLEASE READ INSTRUCTIONS CAREFULLY

- Check the pack and make sure you have all the parts listed.
- When you are ready to start, make sure you have the right tools at hand (not supplied) including a Phillips screwdriver, Stanley knife, Wood saw, Step ladder, Hammer and a Drill with 2mm bit.
- Ensure there is plenty of space and a clean dry area for assembly.

LOCATION FOR YOUR GARDEN BUILDING

A minimum of 60cm should be left around the perimeter of your garden building to allow access for maintenance, annual treatment and to allow air flow around the building.

Where possible you should avoid placing your garden building underneath large trees to prevent the tree causing damage to the building.

TIMBER

As with all natural materials, timber can be affected during various weather conditions. For the duration of heavy or extended periods of rain, swelling of the wood panels may occur. Warping of the wood may also occur during excessive dry spells due to an interior moisture loss. Unfortunately, these processes cannot be avoided but can be helped. It is suggested that the outdoor building is sprayed with water during extended periods of warm sunshine and sheltered as much as possible during rain or snow.

Once your garden building has been installed it will need to be treated as soon as possible and annually to prevent the timber from deteriorating and to waterproof it. This is required to maintain the anti-rot guarantee.

Dip Treated buildings - Require a preservative treatment to protect against rot and decay and a waterproof treatment to prevent water ingress

Pressure Treated buildings - Require a waterproof treatment to prevent water ingress

Log Cabins - Are supplied untreated and require a preservative and waterproofing treatment.

BUILDING A BASE

When thinking about where the building and base is going to be constructed: Ensure that there will be access to all sides for maintenance work and annual treatment.

Ensure the base is level and is built on firm ground, to prevent distortion. Refer to diagrams for the base dimensions, The base should be slightly smaller than the external measurement of the building, i.e. The cladding should overlap the base, creating a run off for water. It is also recommended that the floor be at least 25mm above the surrounding ground level to avoid flooding.

TYPES OF BASE

- Concrete 75mm laid on top of 75mm hard-core.
- Slabs laid on 50mm of sharp sand.

Whilst all products manufactured are made to the highest standards of Safety and in the case of childrens products independently tested to EN71 level, we cannot accept responsibility for your safety whilst erecting or using this product.



x2

All buildings should be erected by two adults



Winter = High Moisture = Expansion
Summer = Low Moisture = Contraction



2mm Drill bit

For ease of assembly, you **MUST** pilot drill all screw holes and ensure all screw heads are countersunk.



CAUTION

Every effort has been made during the manufacturing process to eliminate the prospect of splinters on rough surfaces of the timber. You are strongly advised to wear gloves when working with or handling rough sawn timber.



For ease of assembly, you will need a tape measure to check dimensions of components.

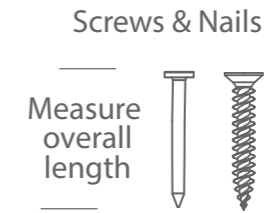

Measure overall length

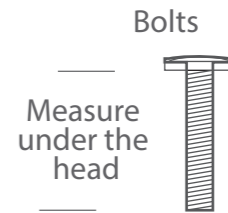

Measure under the head

To identify the fixings required for each step use a measuring tape.

****Protim Aquatan T5 (621)****

Your building has been dip treated with **Aquatan**.

Aquatan is a water-based concentrate which is diluted with water, the building as been treated by the correct application of Aquatan solution and then allowed to dry.

Aquatan is a decorative finish to colour the wood, which is applied industrially to timber fence panels and garden buildings.

Aquatan undiluted contains: boric acid, sodium hydroxide 32% solution, aqueous mixture of sodium dioctyl sulphosuccinat and alcohols: 2, 4, 6-trichlorophenol.



REGISTER FOR YOUR
ANTI-ROT
GUARANTEE TODAY

PLEASE SCAN HERE:



For assistance please contact customer care on: 01636 821215

**Mercia Garden Products Limited,
Sutton On Trent,
Newark,
Nottinghamshire,
NG23 6QN**

www.merciagardenproducts.co.uk



Overall Dimensions:

Width = 2096mm
Depth = 873mm
Height = 1798mm

Base Dimensions:

Width = 1976mm
Depth = 795mm

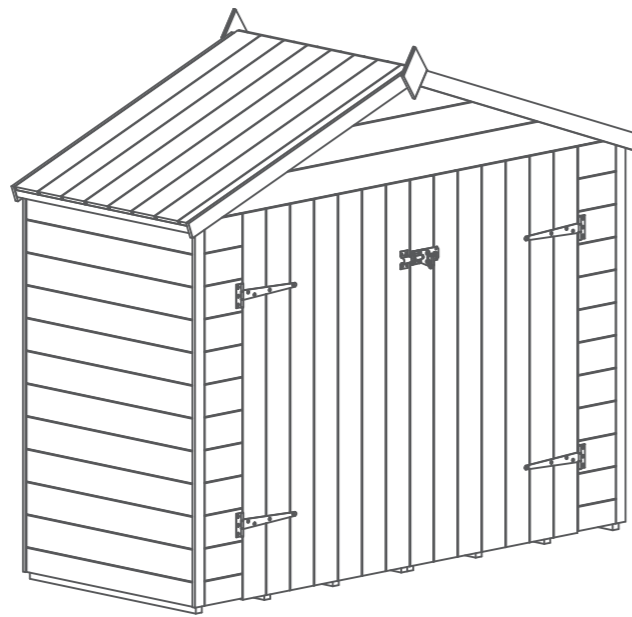

Before assembly
please make sure you have a
suitable base ready to erect your
building

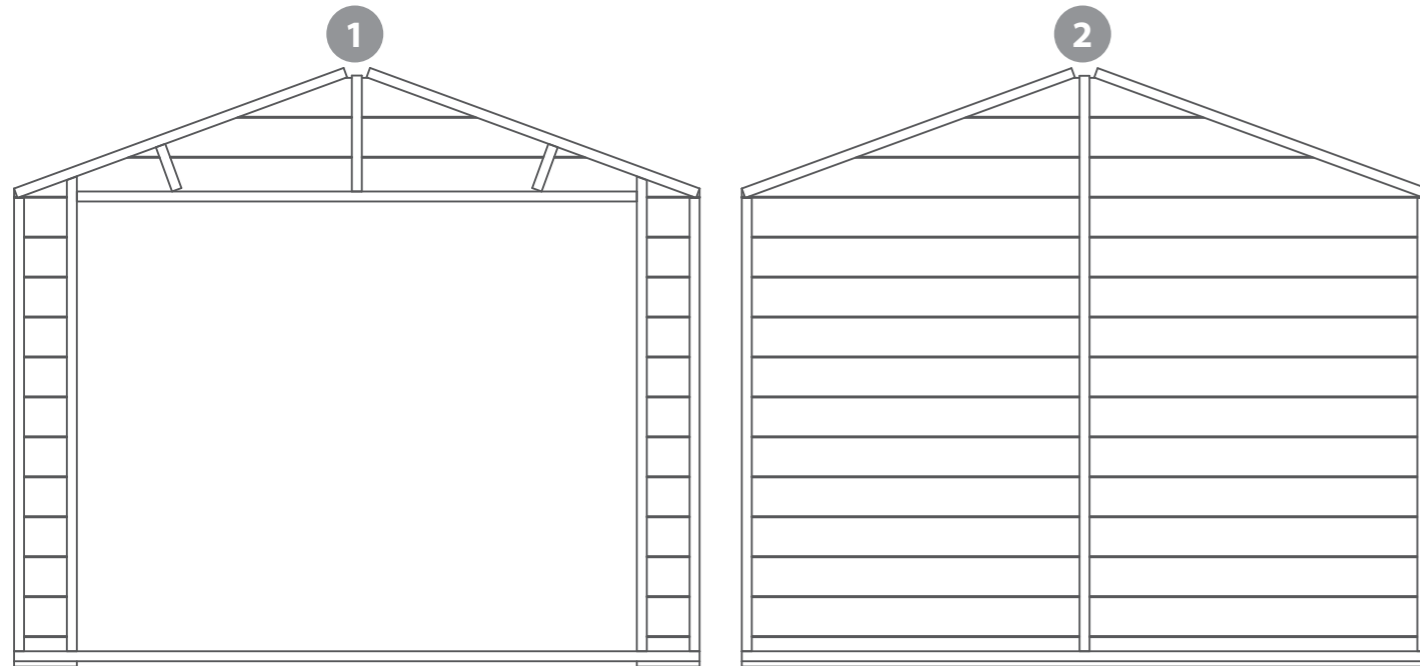

Door Gable Qty 1
AI-05S11MBAGDD1922X1678-V1

Plain Gable Qty 1
AI-05S11MBAGP1922X1678-V1

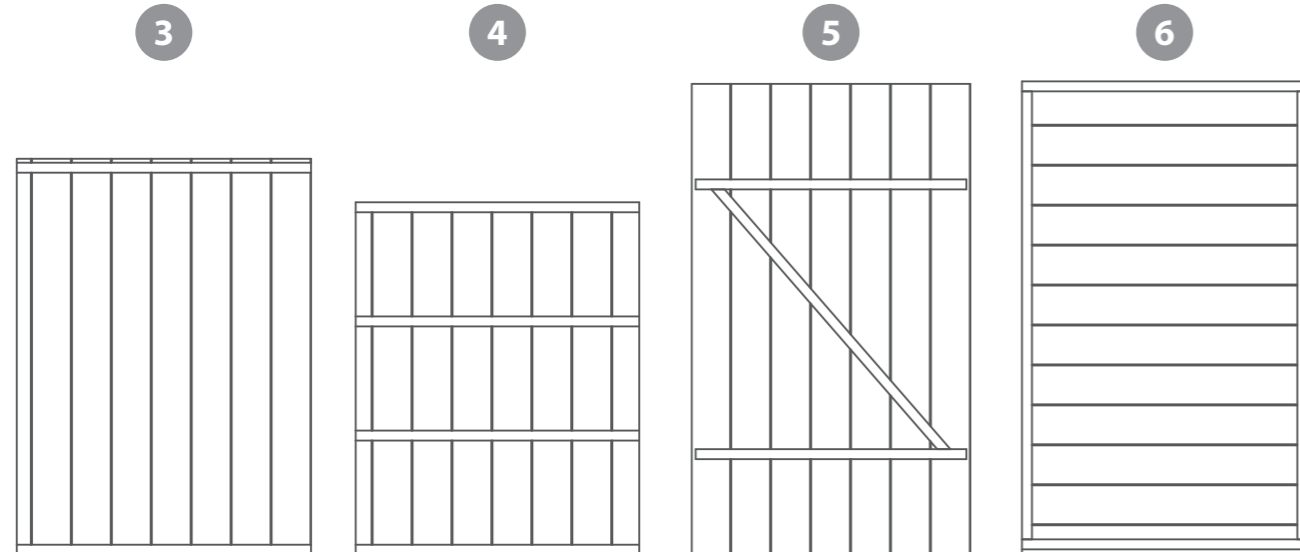

Roof Qty 2
AI-S11MBOHAR1110X825-V1

Floor Qty 2
AI-R11MBF795X988-V1

Door Qty 2
AI-S11FBMBZBD781X1320-V1

Plain Side Qty 2
AI-S11MBPP800X1327-V1



Bolt Block 28x28x132mm Qty 4
FS2828-132mm



Fascia 12x56x1095mm Qty 4
s1256-1095mm

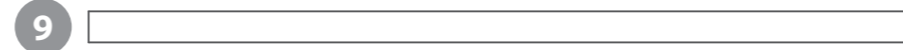

Ridge Bar 28x28x744mm Qty 1
FS2828-744mm



Cover Trim 12x45x1324mm Qty 4
S1245-1324mm



Door Trim 12x27x1261mm Qty 2
S1227-1261mm

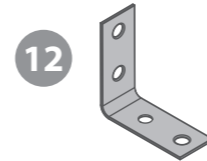

Corner Brace Qty 2
PI-07-0012

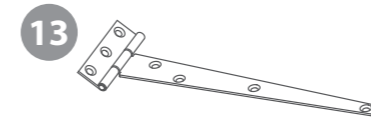

T-Hinge Qty 4
PI-02-1043

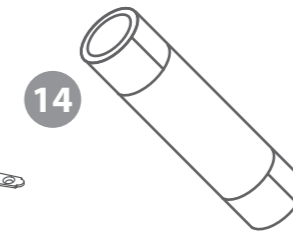

Felt
PI-01-0025

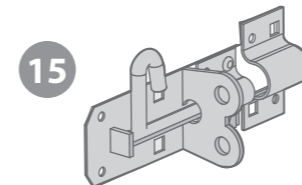

Pad Bolt Qty 1
PI-07-0035



Finial Qty 2
SHED DIAMOND FINIAL



Turn Button Qty 2
PI-07-0034

Nail Bag

There may be extra screws present in the nail bag



Pre Assembly

Before assembling remove the transportation blocks from the bottom of each panel.

Take care removing the blocks as to not damage the panels. Tap with a flat headed screwdriver and hammer.

Dispose of the blocks once removed.

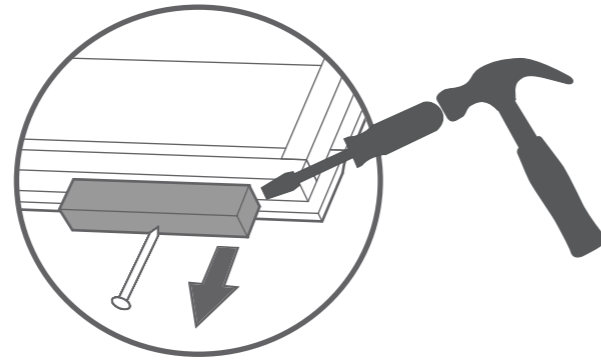

Step 2

Parts Needed - No. 4 Qty 2

Place the floors (No. 4) on a firm and level base, ensure the base has suitable drainage, free from areas where water can collect (see front page for base requirements).

Position the floors side by side as shown in the diagram. Fix together using 4 x 50mm screws alternating the fixing position along the length of the floor.

5 x 50mm Screws

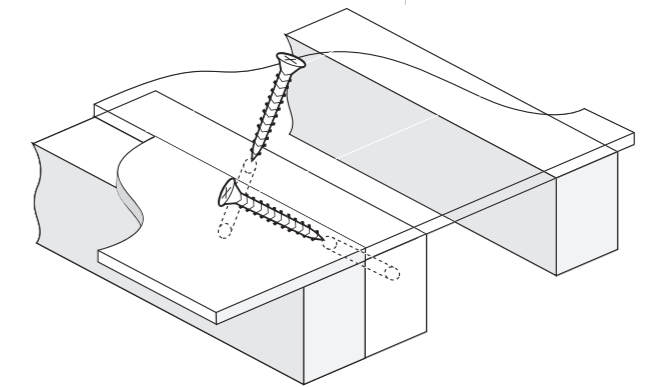
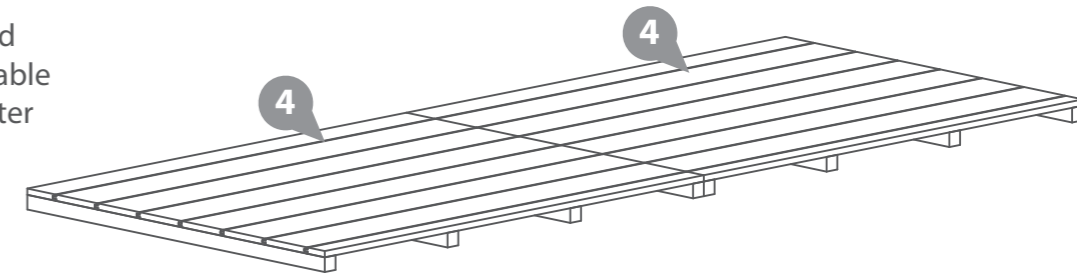

IMPORTANT: Pre-drill before fixing screws.

Step 1

Parts Needed - No. 1 Qty 1
No. 5 Qty 2
No. 13 Qty 4

Place the door gable (No. 1) on to a flat surface and place both doors (No. 5) into the door aperture.

Locate the four hinges (No. 13) onto the doors and door gable ensuring they sit over the door framing. Fix the hinges to the door and door gable using 7x30mm screws per hinge.

28 x 30mm Screws

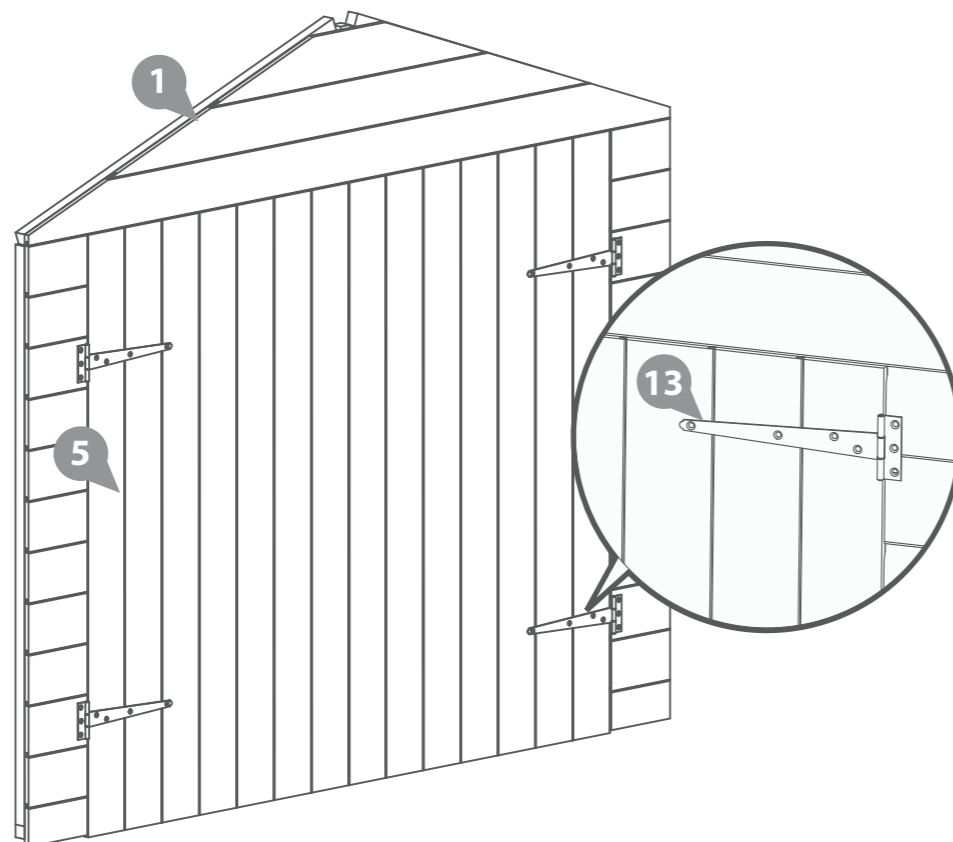
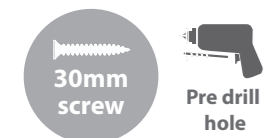

IMPORTANT: Pre-drill before fixing screws.

Step 3

Parts Needed - No. 2 Qty 1
No. 6 Qty 1

Fix the corner with 3x 50mm screw as shown in diagram.

Do not secure the building to the floor until the roof is fitted.

3 x 50mm Screws

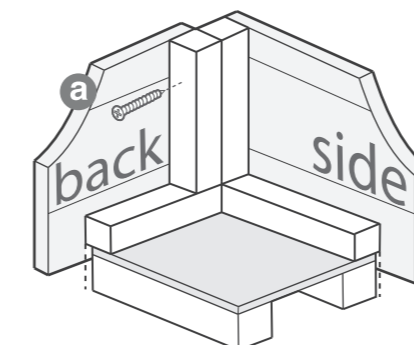

IMPORTANT: Pre-drill before fixing screws.

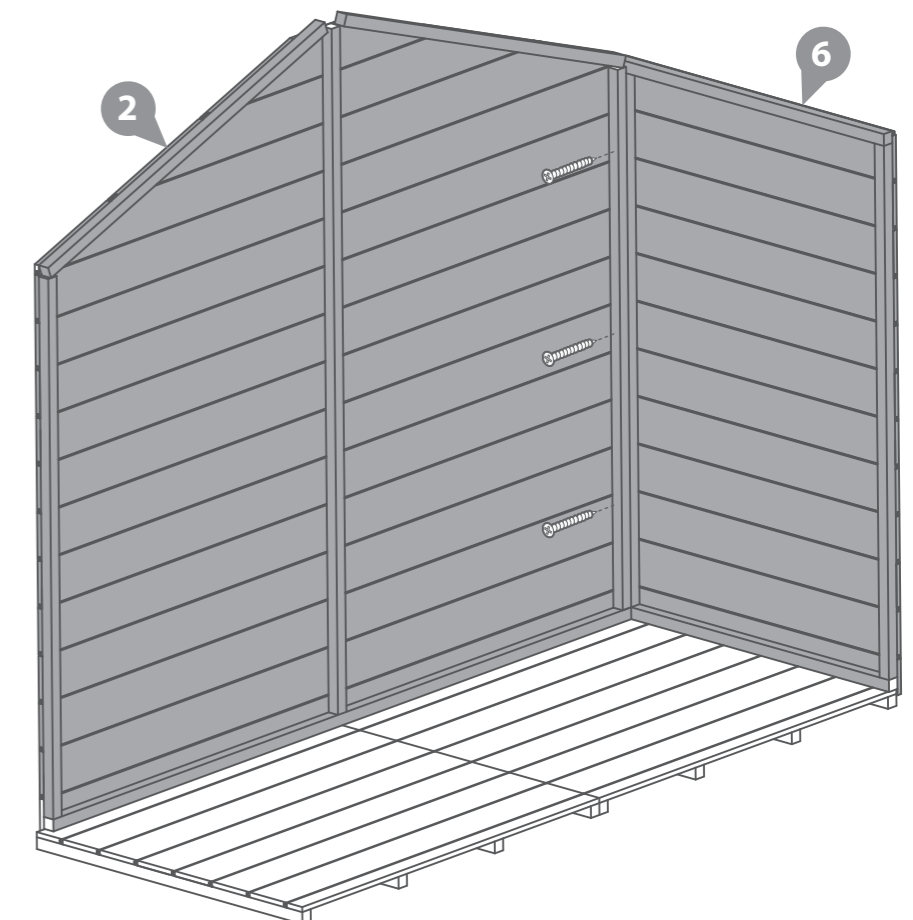

Step 4

Parts Needed - No. 1 Qty 1
No. 6 Qty 1

- a** Fix the corners of the Door Gable (No.1) and the Plain Panels (No.6) with 3x 50mm screw as shown in diagram. Do not secure the building to the floor until the roof is fitted.

9 x 50mm Screws

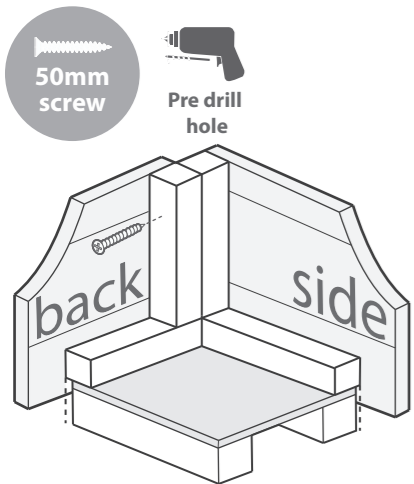

IMPORTANT: Pre-drill before fixing screws.

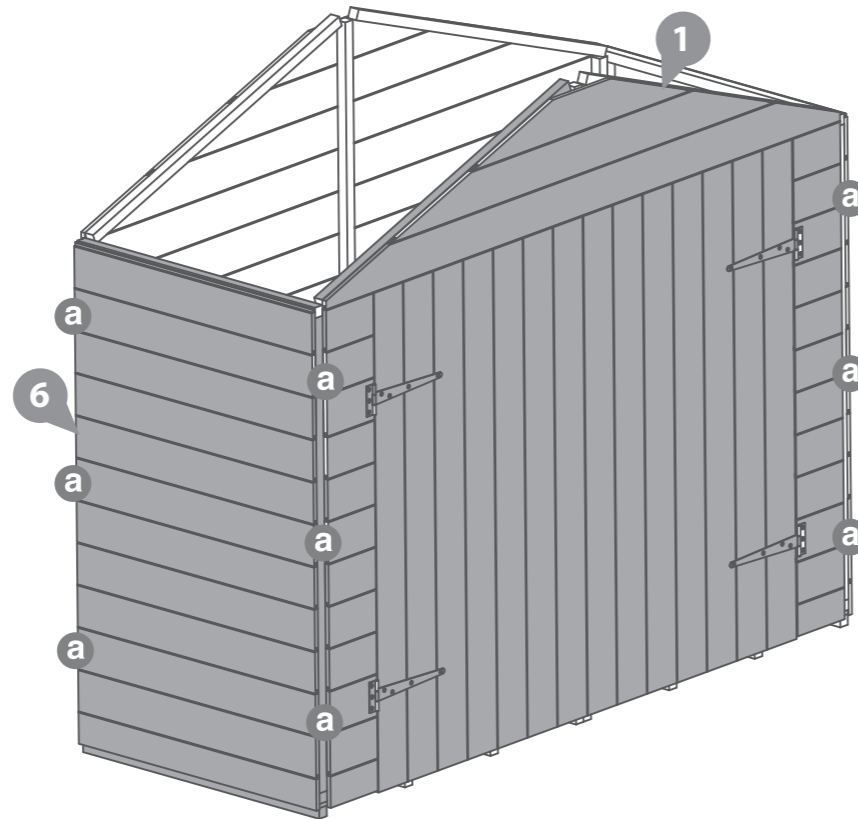

Step 6

Parts Needed - No. 3 Qty 2

Attach the roof (No.3) using 7 x 30mm screws on each side.

Secure the roofs (No.3) into place using 7 x 30mm screws, ensure the roof sits square over the building and the screws go through the roof (No.3) into the panel framing below.

14 x 30mm Screws

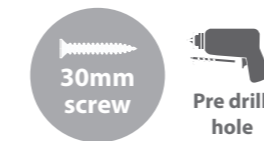

IMPORTANT: Pre-drill before fixing screws.

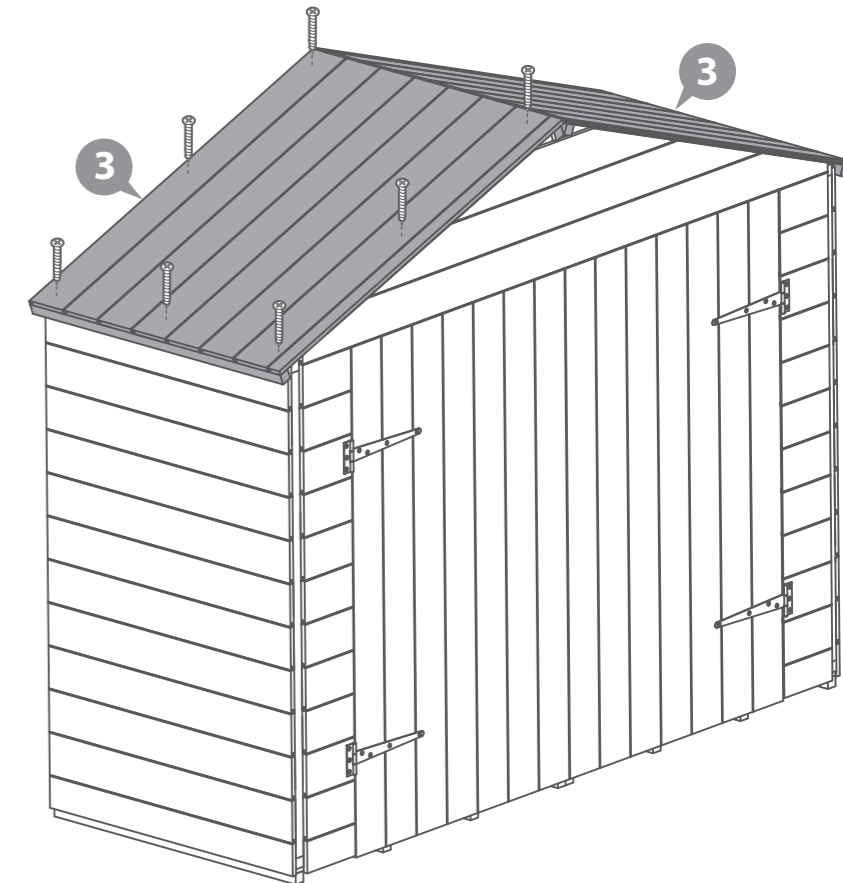

Step 5

Parts Needed - No. 9 Qty 1
No. 12 Qty 2

Locate the Ridge Bar (No.9) in line with the central framing of the gable tops (No.1 & 2).

Fix in place with one Corner Brace (No.12) at each end, using 4x30mm screws per brace.

8 x 30mm Screws

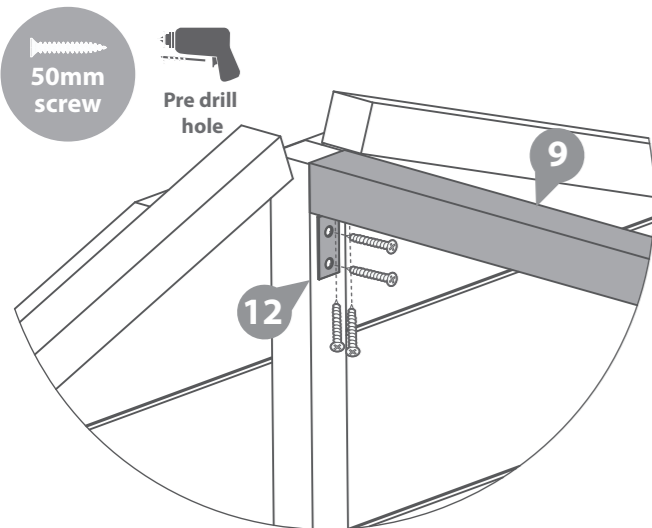

IMPORTANT: Pre-drill before fixing screws.

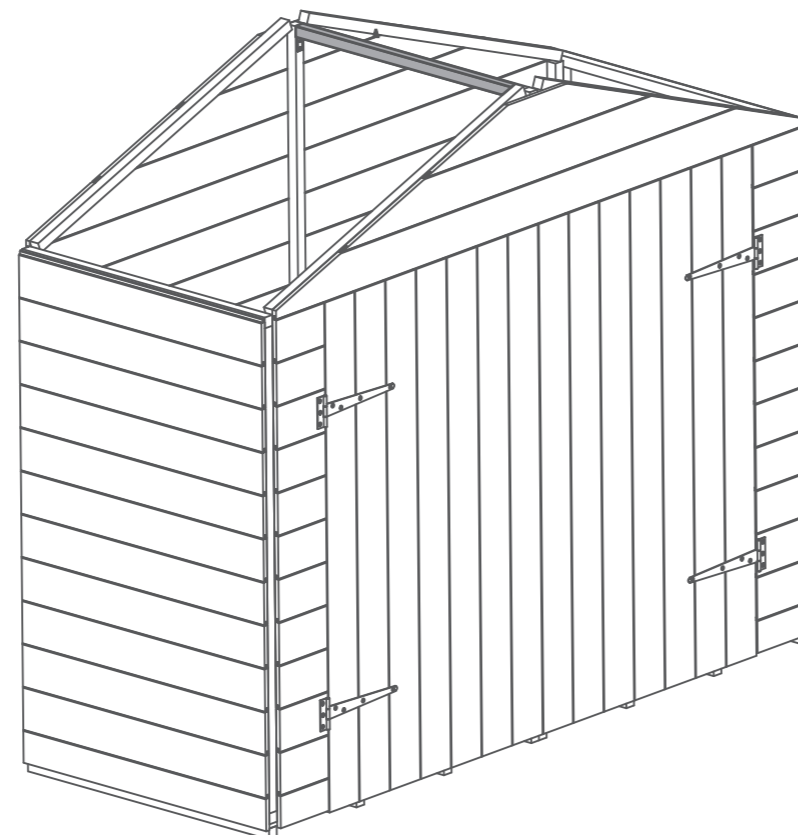

Step 7

- b** Secure the building to the floor using 12 x 50mm screws.

12 x 50mm Screws

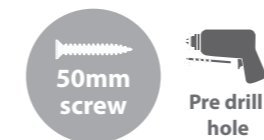

IMPORTANT: Pre-drill before fixing screws.

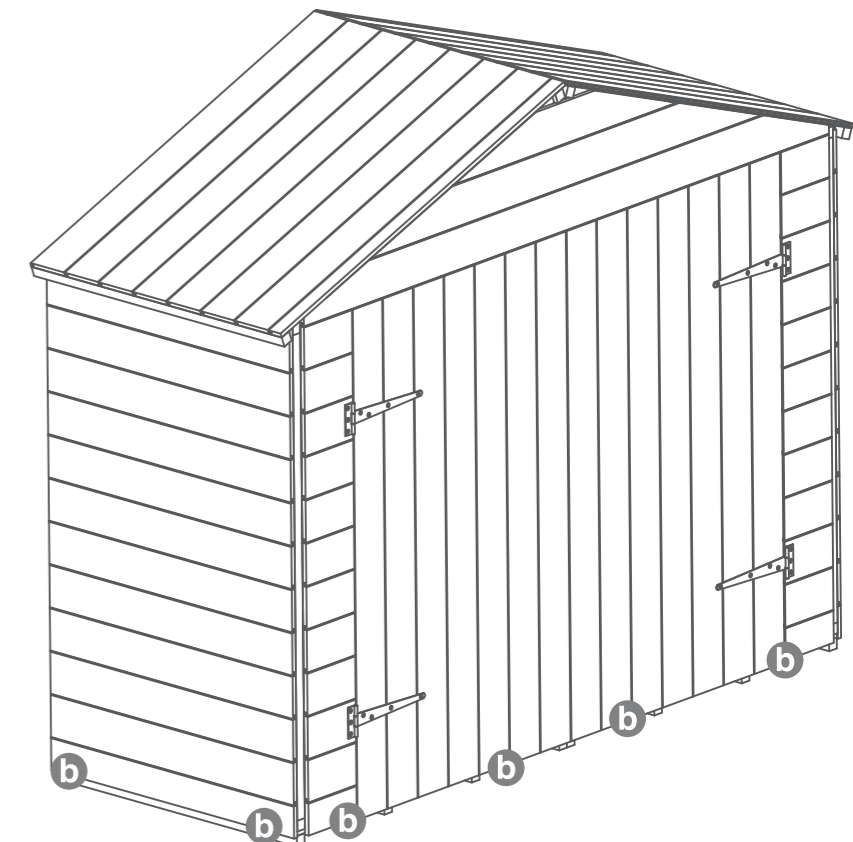

Step 8

Parts Needed - No. 14 Qty 1

Cut one strip of felt (No. 14) to 2320mm length and place it over the roof. Fix the felt in place with felt tacks spaced 100mm apart.

30 x Felt Tacks

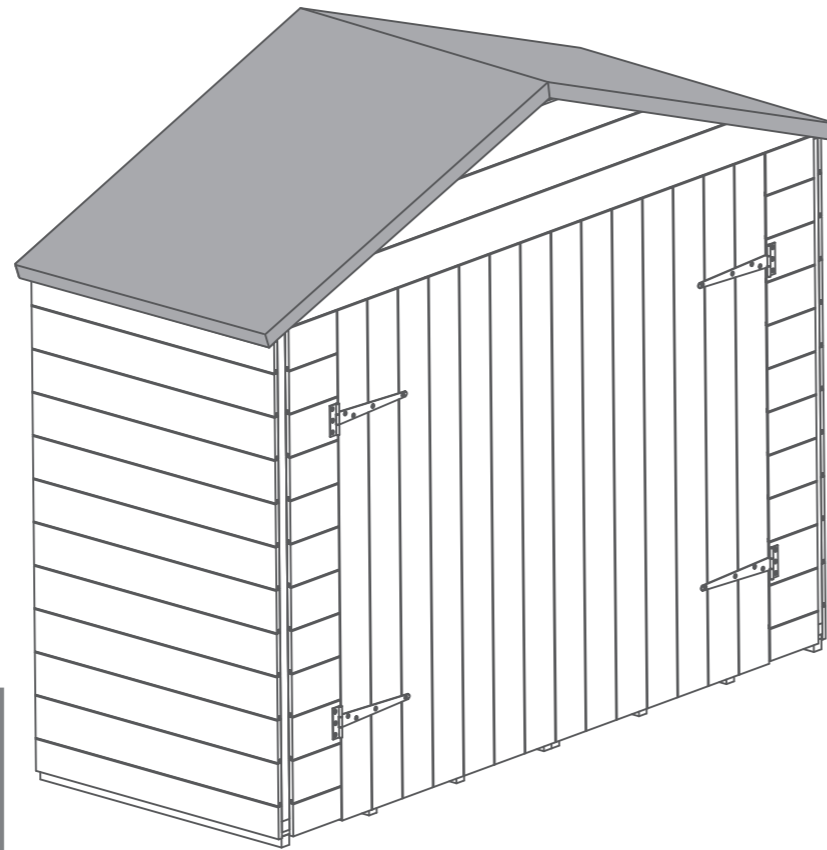
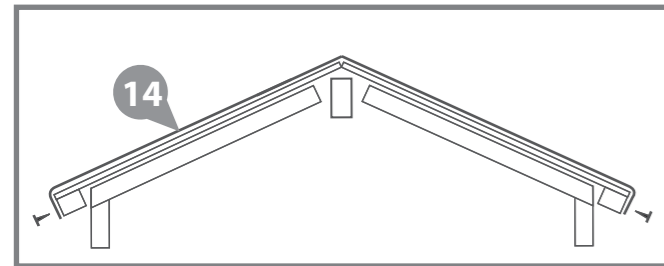

Step 9

Parts Needed - No. 8 Qty 4
No. 16 Qty 2

Fit the fascias (No.8) to the roof over the felt and secure in place with 40mm screws as shown. Pre drill to avoid splitting.

Attach the finial (No.16) to the fascias at the front and the back of the building using 2 x 30mm screws per finial.

16 x 30mm Screws

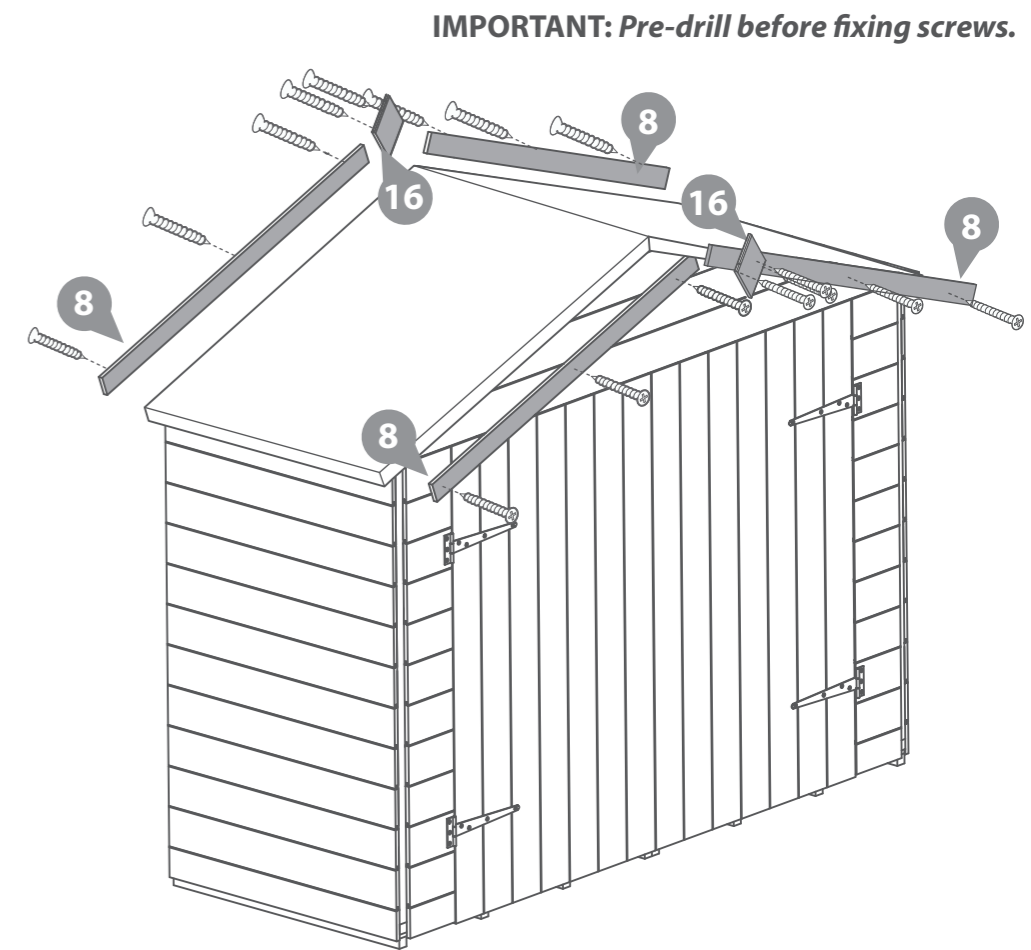

IMPORTANT: Pre-drill before fixing screws.

Step 10

Parts Needed - No. 10 Qty 1

Fit the Cover Trims (No.10) to the front and back of the building as shown in the illustration using 30mm screws. Trim the length of the cover trims to the required size before fitting if necessary. Pre drill to avoid splitting.

12x30mm Screws

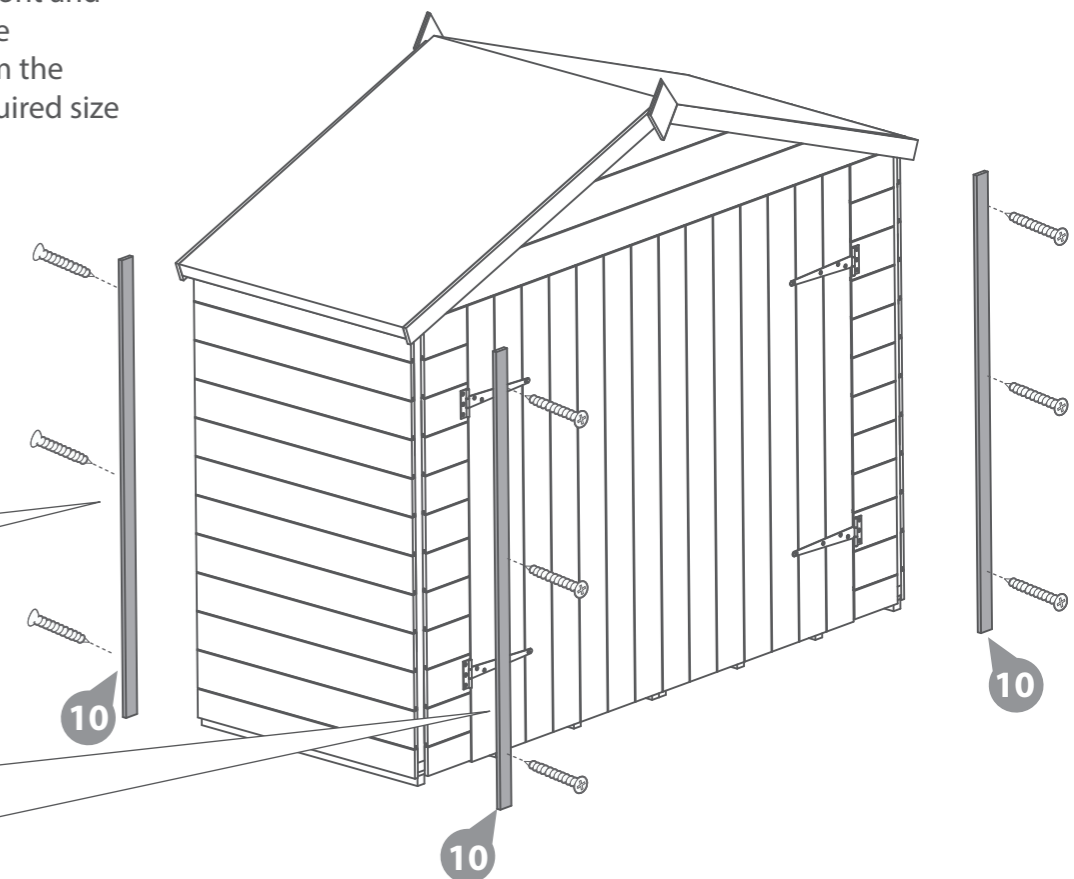
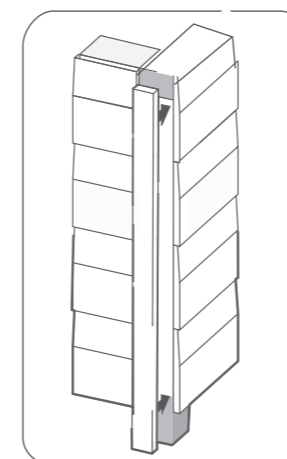
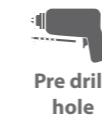

IMPORTANT: Pre-drill before fixing screws.

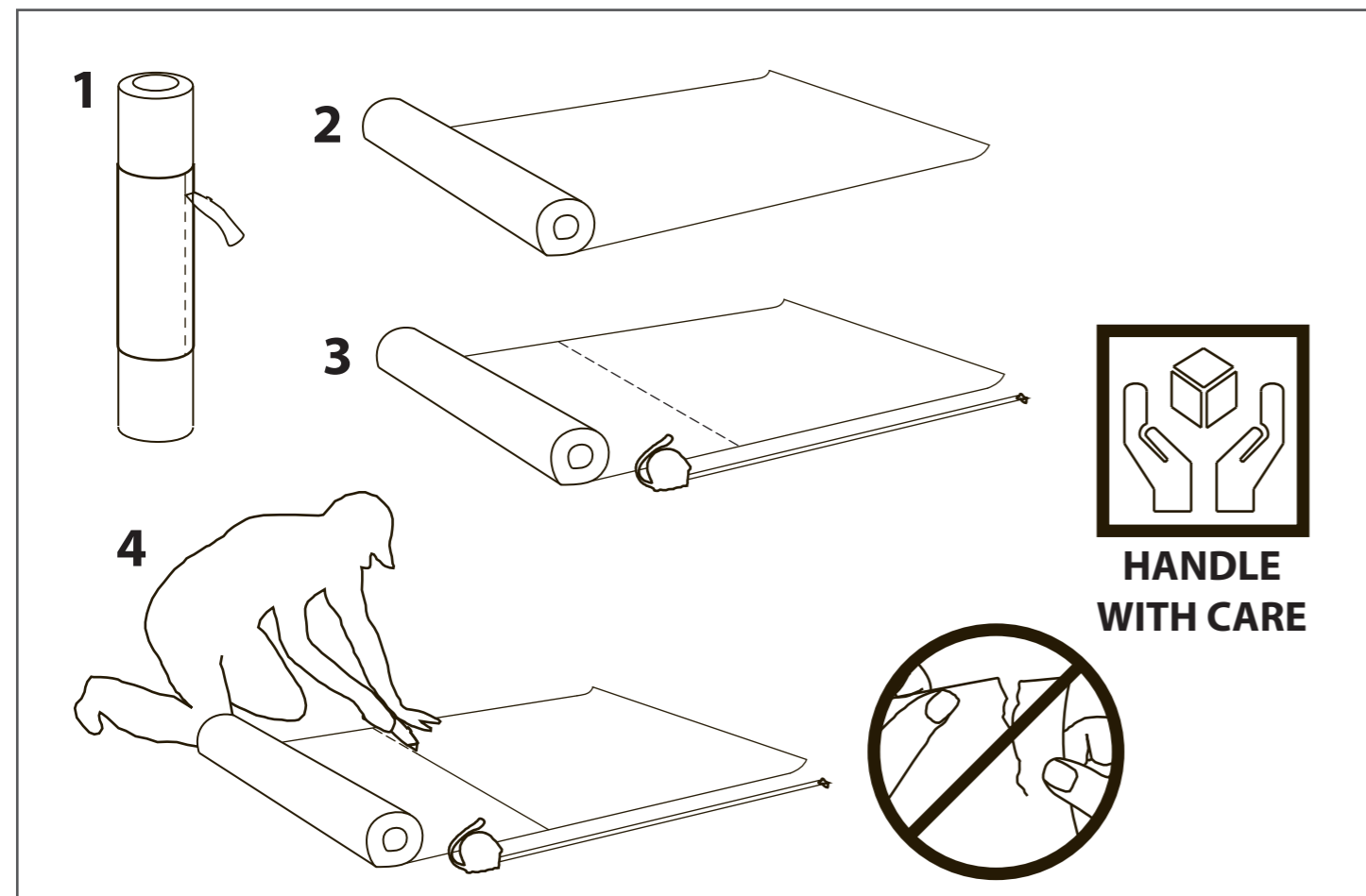

Step 11

IMPORTANT: Pre-drill before fixing screws.

Parts Needed - No. 7 Qty 4

Attach the bolt blocks (**No. 7**) to the doors using 2 x 30mm screws, in the positions illustrated. Screw through the door cladding into the blocks using 30mm screws.

8 x 30mm Screws

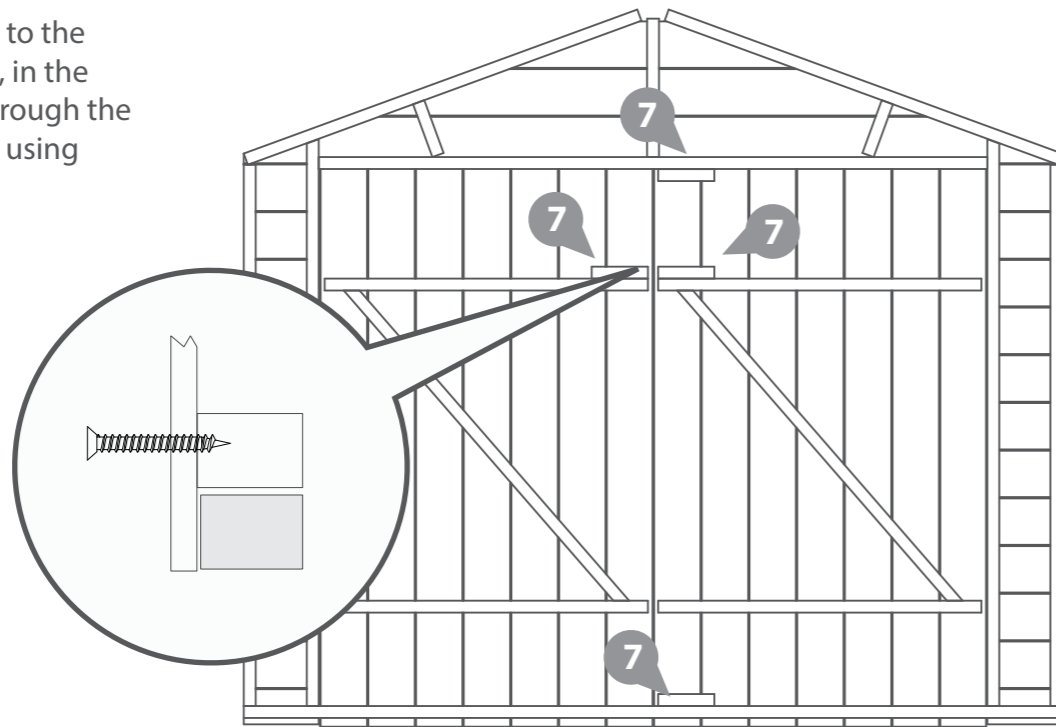

Step 13

IMPORTANT: Pre-drill before fixing screws.

Parts Needed - No. 11 Qty 2

Locate the Door strips (**No.11**) onto the door gable and fix into place using 3x30mm screws. Ensure that the screw is parallel with the door frame when fixing, as shown in the close up view.

6 x 30mm Screws

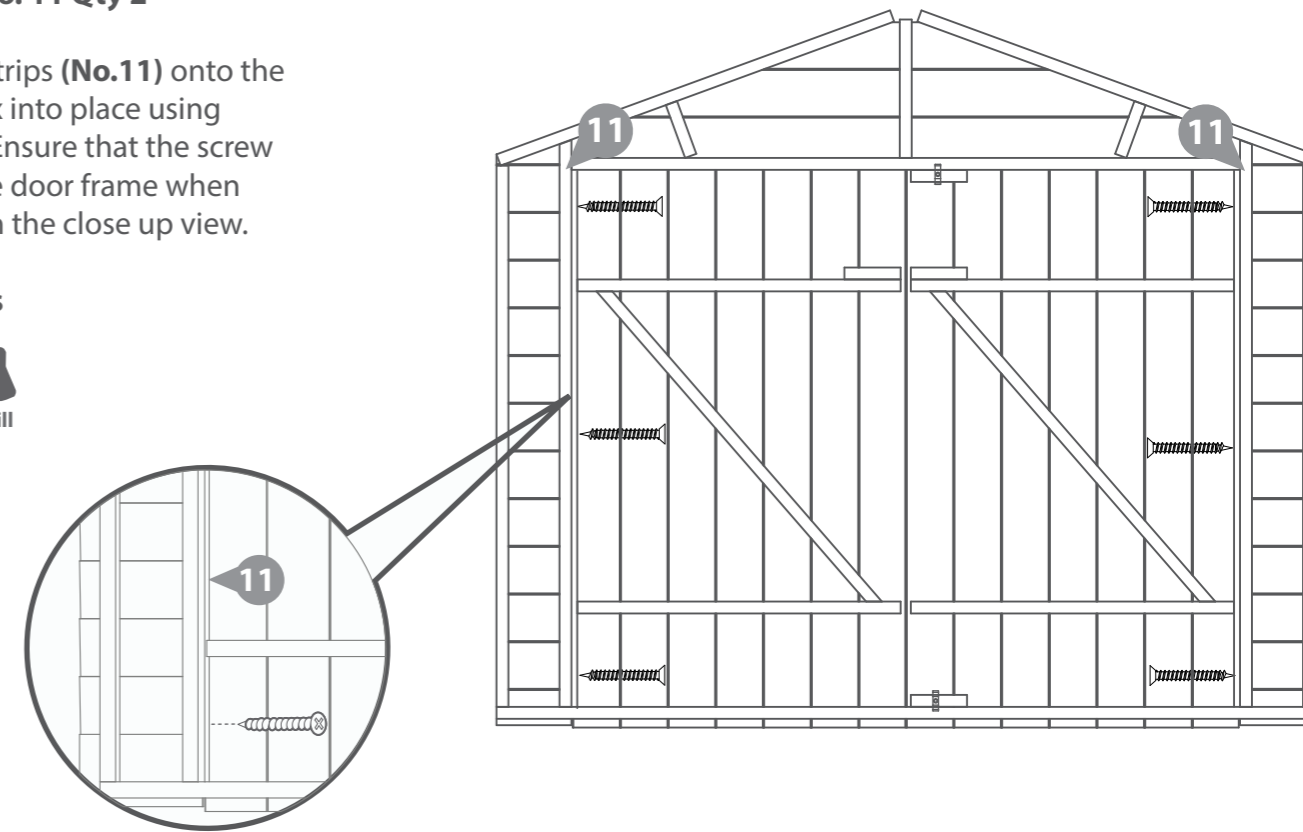
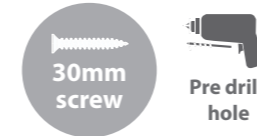

Step 12

IMPORTANT: Pre-drill before fixing screws.

Parts Needed - No. 17 Qty 4

Fix the turn buttons (**No. 17**) to the bolt blocks at the top and bottom of the door using a 30mm screw per turn button.

2 x 30mm Screws

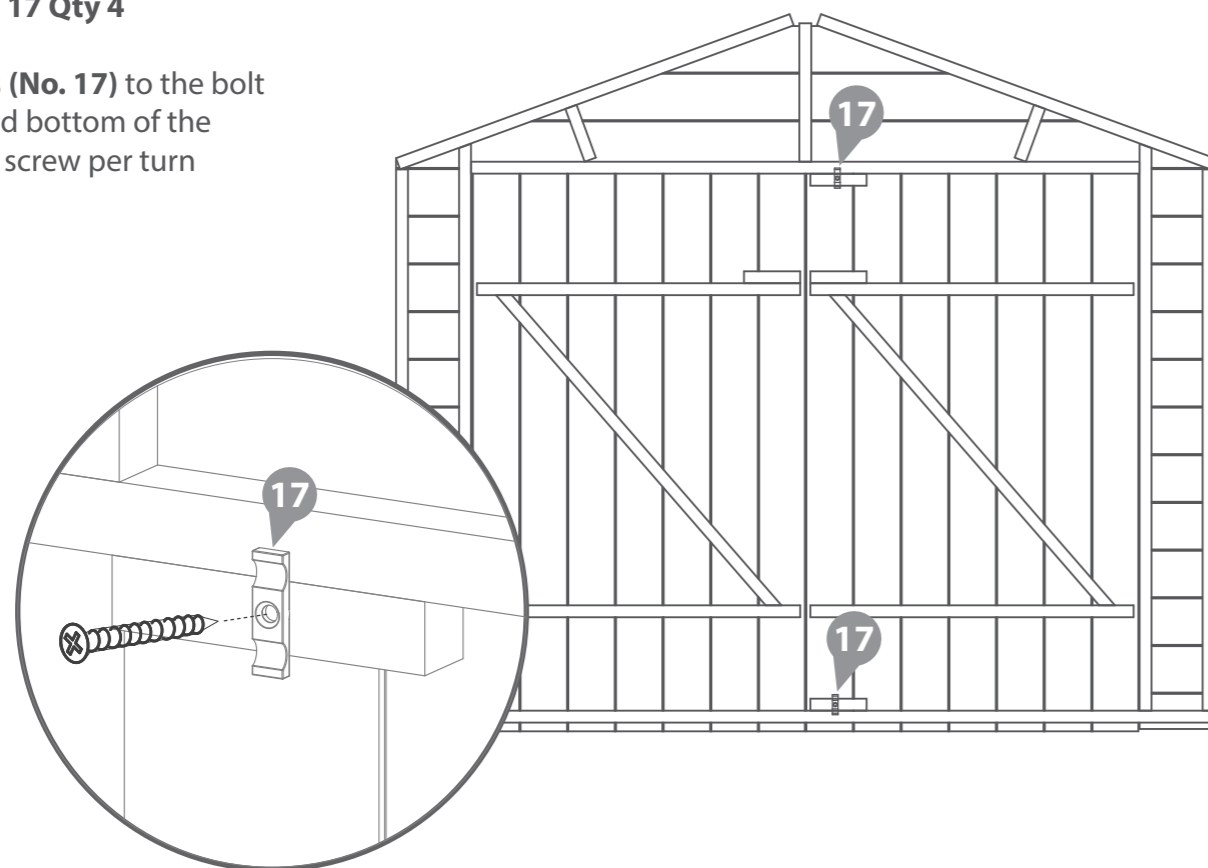

Step 14

Parts Needed - No. 15 Qty 4

Fix the pad bolt (**No. 15**) to the door using 8 x 30mm screws. Ensure the pad bolt lines up with the block on the back.

Attach the retainer to the opposite door in-line with the bolt block (**No.15**) using 4 x 30mm screws.

12x 30mm Screws

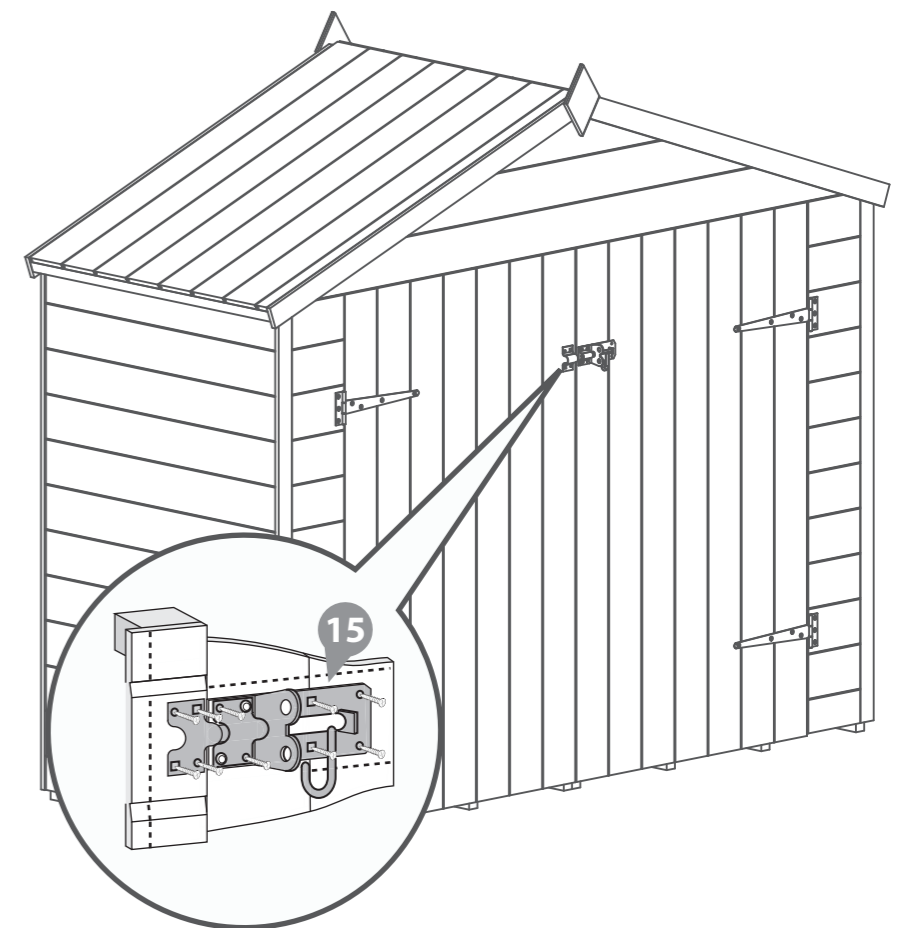

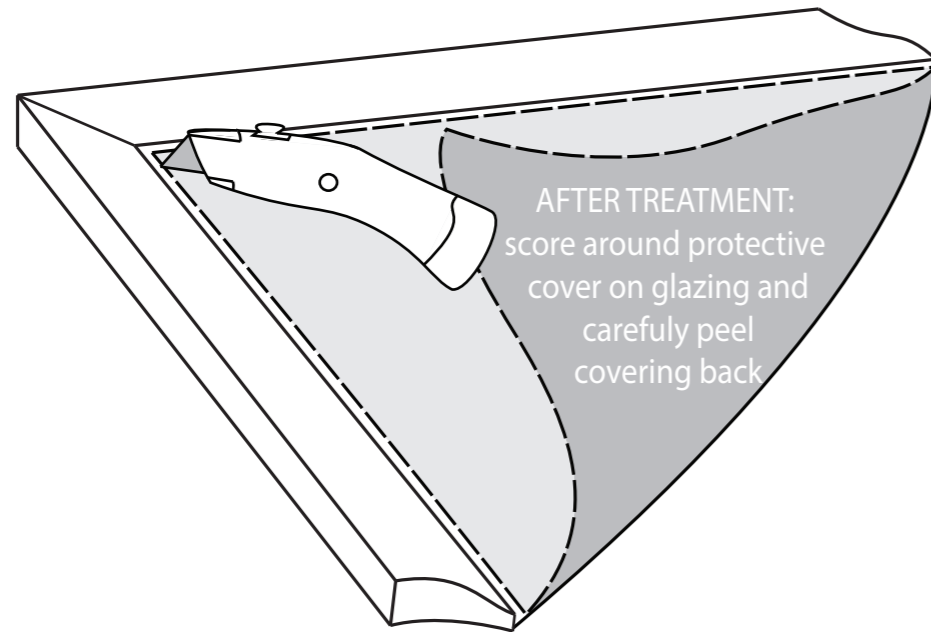

All our garden buildings have been designed and manufactured with care and attention to be the perfect addition to your outdoor space. To ensure you do get the best out of your new garden building and to increase the longevity we advise that you follow the product instructions and our manufacturer's recommendations as detailed below. Thank you for choosing a Mercia Garden product!

1 Choosing the most suitable location for your garden building...

A minimum of 60cm should be left around the perimeter of your garden building to allow access for maintenance, annual treatment and to allow air flow around the building.

Where possible you should avoid placing your garden building underneath large trees to prevent the tree causing damage to the building.

2 Preparing the base for your garden building...

All our buildings must be built on a firm, level base to ensure the longevity of the building and prevent the wood from distorting. We recommend either concrete, concrete slabs or a wooden base, such as our 'Portabase'.

The base should be slightly smaller than the external measurement of the building, i.e. the cladding should overlap the base, creating a run off for water and preventing water from pooling underneath the building.

We also recommend that the floor of the garden building is a minimum of 25mm above the surrounding ground level to avoid flooding.

3 After installation...

Once your garden building has been installed it will need to be treated as soon as possible and annually to prevent the timber from deteriorating and to waterproof it. This is required to maintain the anti-rot guarantee.

Dip Treated buildings - Require a preservative treatment to protect against rot and decay and a waterproof treatment to prevent water ingress

Pressure Treated buildings - Require a waterproof treatment to prevent water ingress

Log Cabins/Insulated Garden Rooms - Are supplied untreated and require a preservative and waterproofing treatment

We also recommend using a silicon sealant on the inside and outside of the windows as soon as possible after assembly and treatment to fully seal the windows.

Roofing felt/covering should be checked annually and replaced or fixed accordingly.

4 General maintenance and wood characteristics

As wood is a natural material it may be affected by the following:

Shrinkage and warping - The timber used in the construction of your garden building will have retained some of its natural moisture content. The moisture content of the timber will vary, depending upon prevailing environmental conditions, which will result in the components either naturally expanding or contracting. As the components dry out shrinkage may occur. A good waterproofing treatment from the start is the best protection to minimise the effect of moisture loss/intake.

In extended periods of very warm weather getting some moisture to the building will help the overall balance. You can do this by spraying it down lightly with a garden hose. In contrast after snow fall try to remove the snow as best as possible from the roof to prevent moisture intake and to remove the extra weight.

Top tip - using a garden brush will help you to reach the highest part of the building to remove snow and any debris left from bad weather.

Damp and mould - During the winter months, cold and damp conditions can result in an increased amount of moisture within your garden building, especially when used infrequently. Condensation can form on the timber and other items stored within your garden building. If left this moisture is likely to cause mould and mildew. To prevent the build-up of moisture, we recommend leaving the door or windows of your building open from time to time, to allow the fresh air to circulate. We also advise against storing wet or damp items in your garden building as this will also increase the level of moisture in the building. If mould or mildew does start to form within your building we recommend using an anti-mould cleaner to remove it and to prevent it spreading, which if left untreated could permanently damage your garden building.

Splits, cracks and knots - You may notice small splits and cracks in some components or holes may appear where knots shrink and fall out. This will not affect the structure of your Garden building however if you wish to fill them this can be easily done using any good quality wood filler.

Sap - is naturally occurring in wood and may appear in some boards of your garden building. If you wish to remove the sap, we advise waiting until it is dry and then using a sharp knife to carefully remove it. If the removal of the sap causes a hole in the timber, we recommend using a good quality wood filler to fill it.

For more handy hints and tips on how to care and maintain your garden building please refer to the MGP Customer Portal at www.mgplogistics.co.uk

Any further questions?

Contact our
Customer Service
Team on:
01636 821215

1 Manufacturer's Warranty

All Mercia Garden Products are supplied with a 1 year warranty on all parts against manufacturing defects.

This warranty does not cover movement, warping or splitting of timber products over time.

This warranty will be voided if any of the following occur:

1. The building has been customised or modified/adapted in any way.
2. The person claiming is not the original purchaser of the building.
3. Any damage has been caused by or as a result of misuse.
4. The building has not been maintained and cared for in accordance to our advisories and manufacturer's recommendations.
5. The building has not been treated annually or as per the manufacturer's recommendations, please ensure receipts are kept to validate this claim.
6. The building has not been erected, fitted or installed as per the supplier instructions.
7. The building has not been erected on a suitable sized firm flat, solid level concrete/slab base or placed on pressure treated bearers.
8. The building is or has been placed with 2 feet (60cm) of any obstructions (walls, trees, plants, fences etc.) which can allow moisture to penetrate the timber.
9. The roofing felt has been incorrectly fitted or damaged allowing water ingress, or not properly maintained.
10. Any windows and joints have not been sealed, inside and out, with silicone or other watertight sealant.
11. Any timber has been cut, pierced or drilled without subsequent application of approved cut-end treatment.

2 Anti-rot Guarantee

Mercia Garden Products offer a 10 year anti-rot guarantee on all dip treated (a preparatory treatment) and 15 years on all pressure treated products. This guarantee covers solid timber against rot, decay, blue stain and insect attack.

To validate the guarantee the building must be treated with a recognised wood preserver/water proof top coat (as detailed within manufacturer's recommendations) as soon as possible after assembly and annually thereafter.

This guarantee does not cover movement, warping or splitting of timber products over time.

This guarantee will be voided if any of the following occur:

1. The building has been customised or modified/adapted in any way.
2. The person claiming is not the original purchaser of the building.
3. Any damage is caused by or as a result of misuse.
4. The building has not been maintained and cared for in accordance to our advisories and manufacturer's recommendations.
5. The building has not been treated annually or as per the manufacturer's recommendations, please ensure receipts are kept to validate this claim.
6. The building has not been erected, fitted or installed as per the supplier instructions.
7. The building has not been erected on a suitable sized firm flat, solid level concrete/slab base or placed on pressure treated bearers.
8. The building is or has been placed with 2 feet (60cm) of any obstructions (walls, trees, plants, fences etc.) which can allow moisture to penetrate the timber.
9. The roofing felt has been incorrectly fitted or damaged allowing water ingress, or not properly maintained.
10. Any windows and joints have not been sealed, inside and out, with silicone or other watertight sealant.
11. Any timber has been cut, pierced or drilled without subsequent application of approved cut-end treatment.