

GLOBEL®

Skillion Roof GARDEN SHED Assembly Instructions

Suitable for Models:

5'w x 3'd

6'w x 3'd

6'w x 4'd

8'w x 3'd

8'w x 4'd

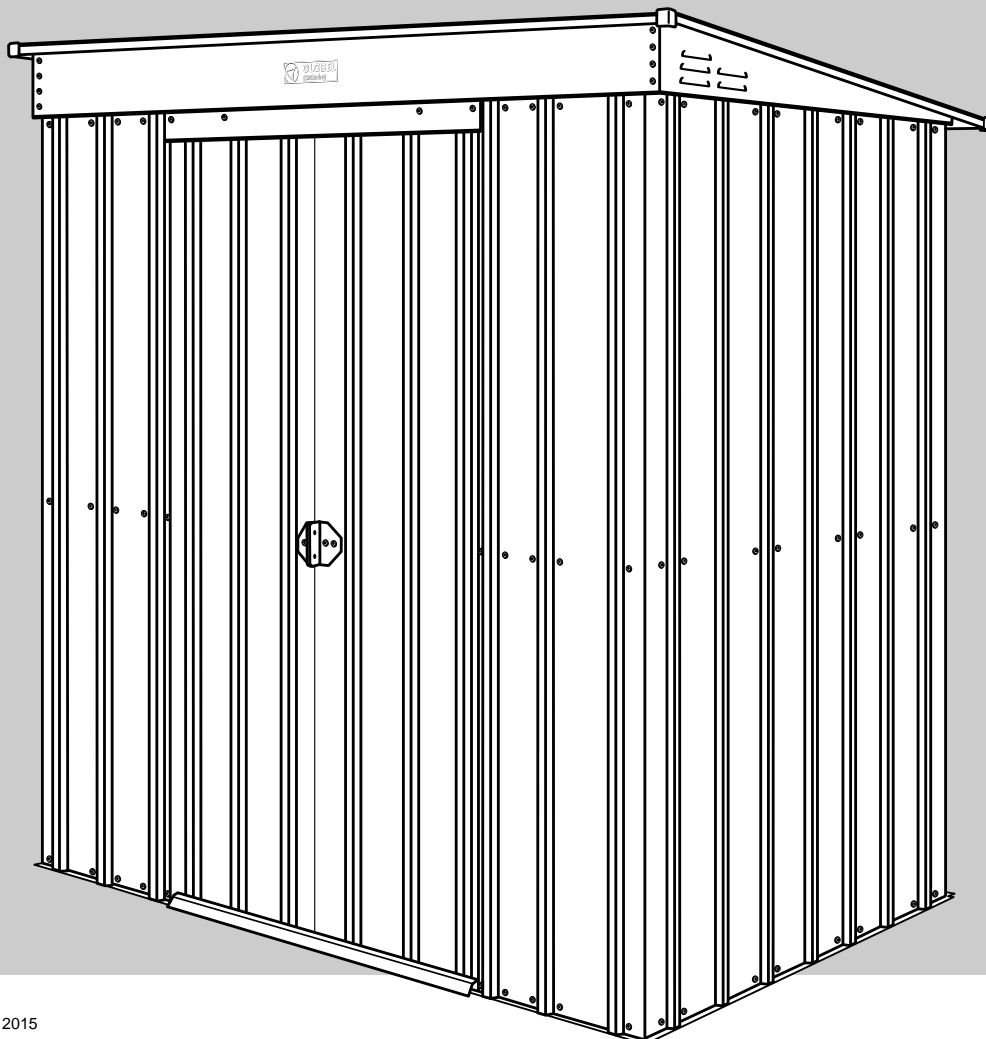

INSTALLATION ADVICE

It's Not That Difficult!

The construction of your shed isn't as complicated as it may first appear.

Our step by step, illustrated instructions are easy to follow, and we provide hints to make the assembly even easier. Simply follow our recommendations and carefully study our illustrations, then your garden shed will be assembled quickly and accurately.

Garden Shed Specifications								
SHED TYPE / SIZE		BASE DIMENSIONS (Front x Sides mm)	ROOF DIMENSIONS (Front x Sides mm)	WALL SHEET HEIGHT mm	OVERALL HEIGHT mm		DOOR OPENING (Height x Width mm)	No. CARTONS (Weight Kg)
Type	Size (Feet)				Front	Back		
Double Sliding Doors	5 x 3	1400 x 820	1480 x 930	1780	1935	1785	1700 x 590	1 (40)
Double Sliding Doors	6 x 3	1710 x 820	1800 x 930	1780	1935	1785	1700 x 625	1 (43)
Double Sliding Doors	6 x 4	1710 x 1130	1800 x 1240	1780	1975	1785	1700 x 625	1(50)
Double Sliding Doors	8 x 3	2340 x 820	2420 x 930	1780	1935	1785	1700 x 1050	2 (55)
Double Sliding Doors	8 x 4	2340 x 1130	2420 x 1240	1780	1975	1785	1700 x 1050	2 (60)

IMPORTANT! Read These Instructions FIRST.

CHECK THE PARTS:

Before you start, separate and identify all the parts and hardware. (Refer to Parts List diagrams in the following pages).

WARNING: Edges are sharp - Handle with care - Using gloves is highly recommended.
Choking Hazard - This product contains small parts.



WE RECOMMEND you get a second pair of hands to assist you with the assembly.

For simplicity, in most part, this manual illustrates the construction of a 6' wide x 4' deep garden shed, with additional instructions for 5' and 8' wide garden sheds inserted where applicable.

Make sure the site you choose for your garden shed is firm and level, and water drains away from the site.

Do not install the garden shed in areas subject to high winds.

Do not assemble the garden shed on a windy day.

Your garden shed should be assembled on a specifically prepared base, ie concrete slab or pavers (or a suitable Garden Shed Foundation Kit) and then secured using the recommended dyna bolts as listed in the "Tools Required" page. A heavy duty polythene sheet should be placed under the foundation to assist in reducing rising dampness from the soil, thus reducing condensation build up in your garden shed.

Once secured, we highly recommend applying silicone along the inside of the base rail to prevent water from seeping under the base frame and into your shed.

Do not backfill against the shed's walls or base, as this will cause corrosion and void the warranty.

Check the labelling on the Parts Cartons to ensure you have the shed model you ordered, and the correct number of Parts Cartons.

TOOLS INFORMATION:

The tools you need are shown in the "TOOLS REQUIRED" section as all holes for screws and nuts and bolts are pre-drilled (excluding one hole only, which will require a 3mm drill bit) you will only need a power screw driver or a cordless drill with a magnetic Phillips-head tip to make the assembly quicker and easier.

Do not over-tighten self-tapping screws.

Nuts can be tightened by holding your finger on them as you tighten the bolt with the power screw driver - no spanner needed.

TOOLS REQUIRED

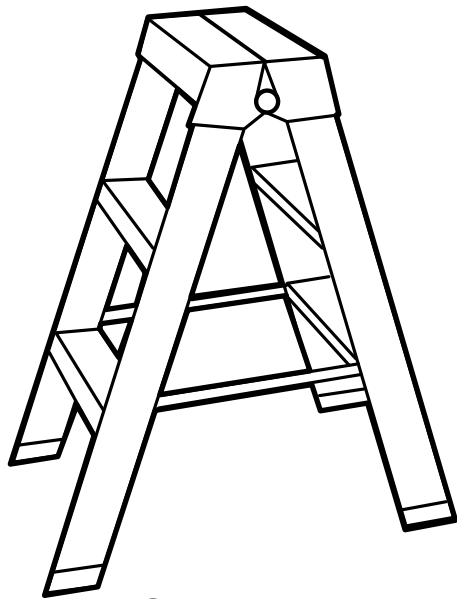

Step Ladder

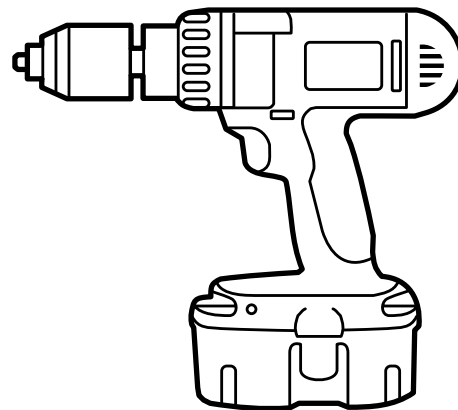

Battery Power Drill

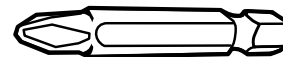

**Phillips-Head
Screw Driver Bit
(P2)**

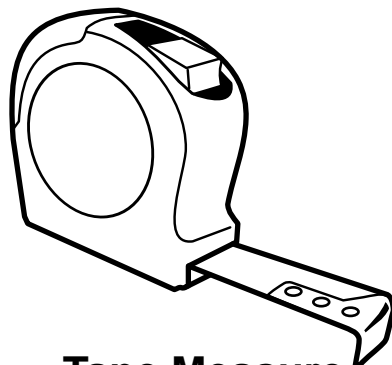

Tape Measure



Dyna Bolts
(not supplied)
6.5mm x 36mm
recommended



**Masonry
Drill Bit**
6.5mm



**Steel
Drill Bit**
3mm

PARTS LIST

SPECIFIC TO MODEL SIZES LISTED

	5' x 3'	6' x 3'	6' x 4'	8' x 3'	8' x 4'
CARTON '1'	QTY	QTY	QTY	QTY	QTY
Corner Panel	4	4	4	4	4
Wall Sheet (Full)	3	4	4	5	5
Wall Sheet (Half)	1	-	2	2	4
Door Jamb	2	2	2	2	2
Roof Sheet (Full)	2	2	2	3	3
Roof Sheet (Half)	-	1	1	1	1
Door	2	2	2	2	2
Roof Starter (Left)	1	1	1	1	1
Roof Starter (Right)	1	1	1	1	1
Front Fascia Panel	1	1	1	1 x Left & 1 x Right	1 x Left & 1 x Right
Above Door Fascia	1	1	1	1	1
Door Brace (Top & Bottom)	2 of each	2 of each	2 of each	2 of each	2 of each
Gable (Left)	1	1	1	1	1
Gable (Right)	1	1	1	1	1
HARDWARE KIT					
NOTE: Hardware Kit is packed in Carton '1' for all models					
Roof Corner Cap	4	4	4	4	4
Corner Brace	6	6	6	6	6
Left Top-Wall Rail Bracket	2	2	2	2	2
Right Top-Wall Rail Bracket	2	2	2	2	2
Door Glide	4	4	4	4	4
Door Glide Roller	16	16	16	16	16
Door Spacer	4	4	4	4	4
Door Handle	2	2	2	2	2
Screws	1 x bag	1 x bag	1 x bag	1 x bag	1 x bag
Nuts	1 x bag	1 x bag	1 x bag	1 x bag	1 x bag
Bolts	1 x bag	1 x bag	1 x bag	1 x bag	1 x bag
Washers	YES	YES	YES	YES	YES
NOTE:					
CARTON '2' - (8' wide wide models only) Carton '2' parts as listed below for 5' wide and 6' wide models are packed in Carton '1'.					
Base Rail (Front)	1	1	1	1	1
Base Rail (Back)	1	1	1	1	1
Side Base Rail (Left)	1	1	1	1	1
Side Base Rail (Right)	1	1	1	1	1
Front Mid-Wall Brace (Left)	1	1	1	1	1
Front Mid-Wall Brace (Right)	1	1	1	1	1
Side Mid-Wall Brace	2	2	2	2	2
Back Mid-Wall Brace	1	1	1	1	1
Right Side Top-Wall Rail	1	1	1	1	1
Left Side Top-Wall Rail	1	1	1	1	1
Front Top Rail	1	1	1	1	1
Back Top Rail	1	1	1	1	1
Front Roof Trim	1	1	1	1	1
Back Roof Trim	1	1	1	1	1
Entry/Exit Ramp	1	1	1	1	1

PARTS LIST - Hardware Kit

WARNING
• **CHOKING HAZARD** - This product contains small parts.

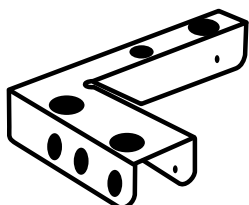

LEFT FRONT & BACK
TOP-WALL RAIL
BRACKET

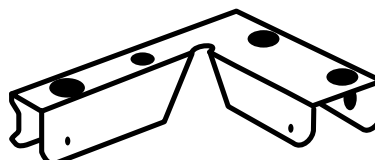

RIGHT FRONT & BACK
TOP-WALL RAIL
BRACKET



DOOR GLIDE



DOOR ROLLER



DOOR SPACER

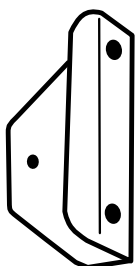

DOOR HANDLE

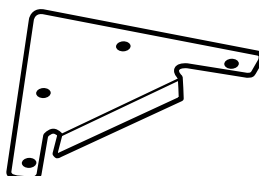

CORNER BRACE



ROOF
CORNER CAP



SCREW



BOLT



NUT

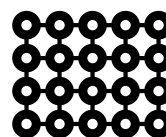

WASHERS

PARTS LIST - Carton '1'

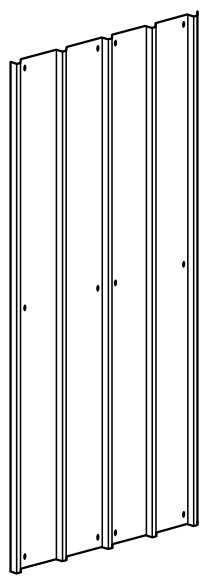

FULL WALL SHEET

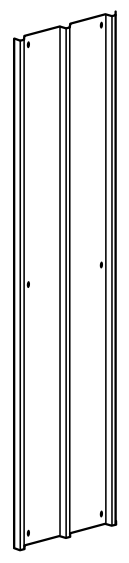

HALF WALL SHEET

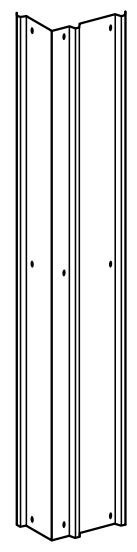

CORNER PANEL

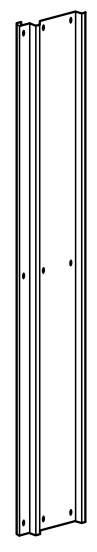

DOOR JAMB (5' & 6' WIDE SHEDS ONLY)

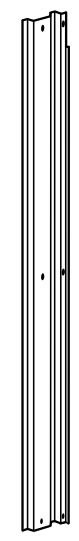

DOOR JAMB (8' WIDE SHEDS ONLY)

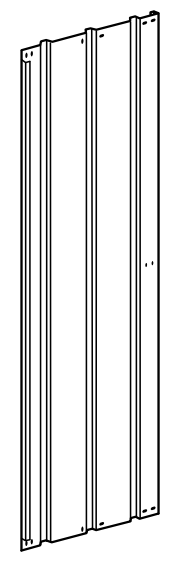

DOOR

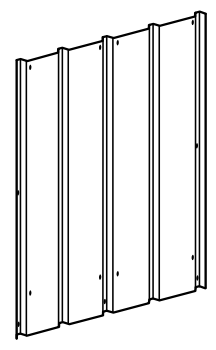

FULL ROOF SHEET

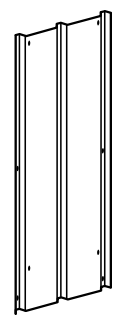

HALF ROOF SHEET

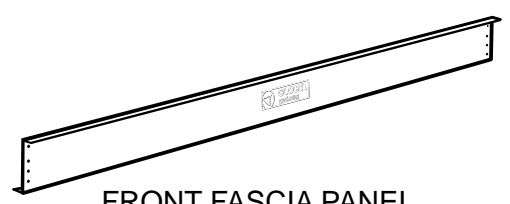

FRONT FASCIA PANEL (5' & 6' WIDE SHEDS ONLY)



LEFT FRONT FASCIA PANEL (8' WIDE SHEDS ONLY)

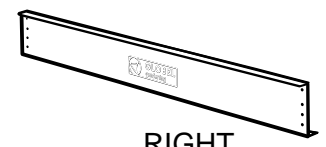

RIGHT FRONT FASCIA PANEL (8' WIDE SHEDS ONLY)

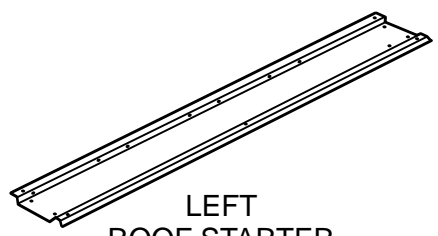

LEFT ROOF STARTER

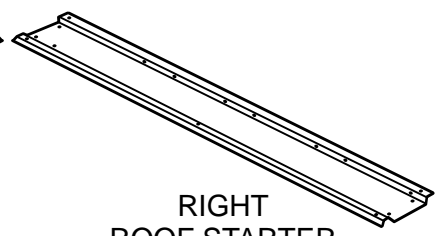

RIGHT ROOF STARTER

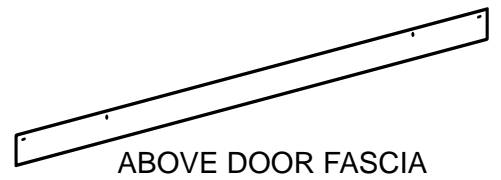

ABOVE DOOR FASCIA

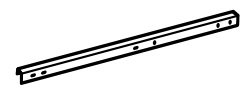

DOOR BRACE

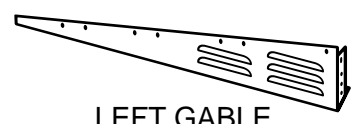

LEFT GABLE



RIGHT GABLE

PARTS LIST - Carton '2'

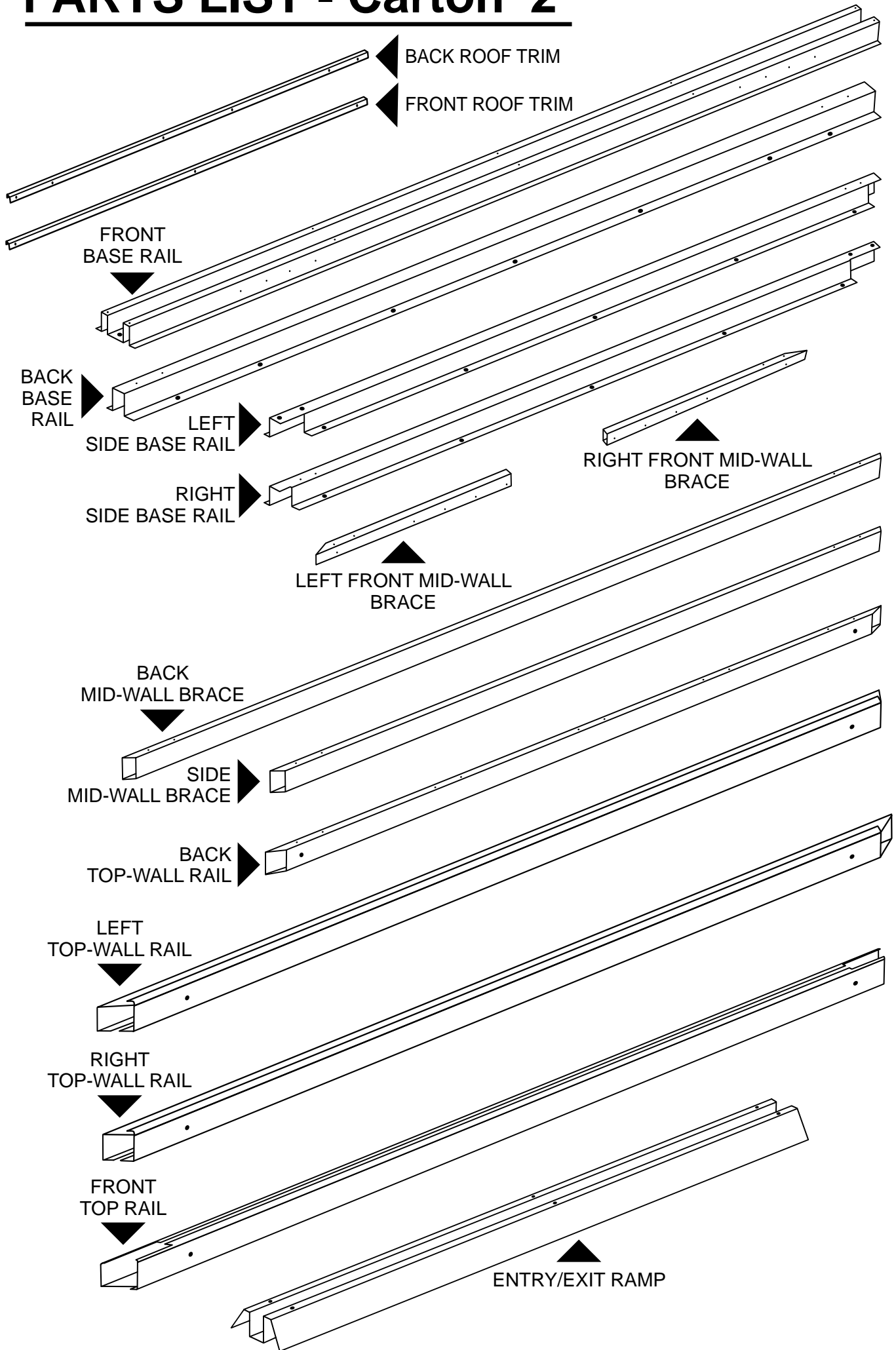

FOUNDATIONS

Your shed requires a solid foundation.

If you need to construct a concrete slab, this page shows the method and dimensions we recommend.

A

Determine the size of the concrete slab

by adding 100mm to the width and 100mm to the depth of the roof size of the shed.

(See Diagram A).

Adding the additional 100mm prevents rainwater from the roof creating a trench, and splashing soil against the walls of the shed, which could cause corrosion.

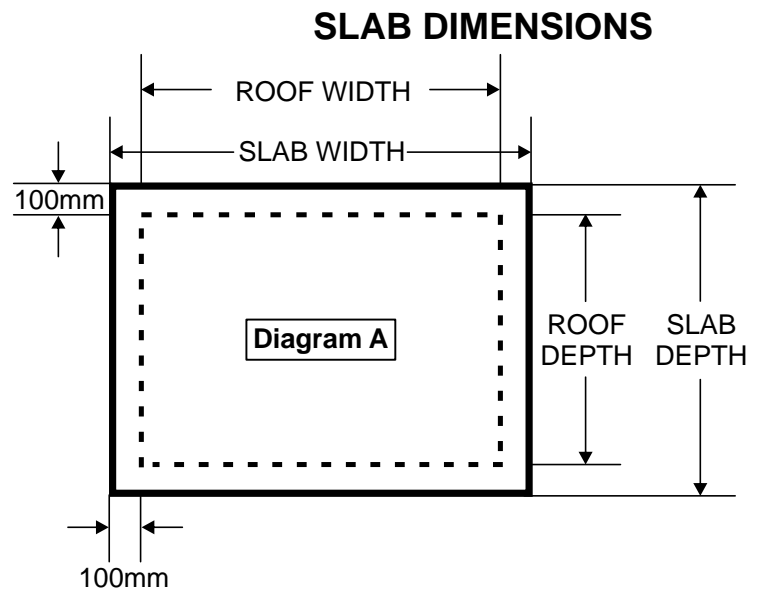

B

Make sure the slab area is square

by ensuring diagonal corner dimensions are equal.

(Diagram B)

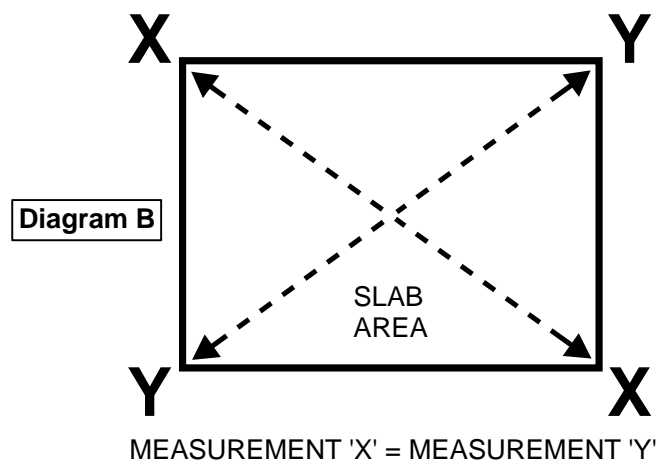

C

Formwork

must be 100mm thick and level. (Diagram C)

First, lay builders plastic on the ground as a barrier to rising moisture. (Diagram D)

Then place F52 reinforcing steel mesh on top of the builders plastic, ensuring the steel mesh is raised off the plastic to a depth of approximately half the thickness of the formwork. (Diagram E)

Then pour the concrete and allow five days to cure.

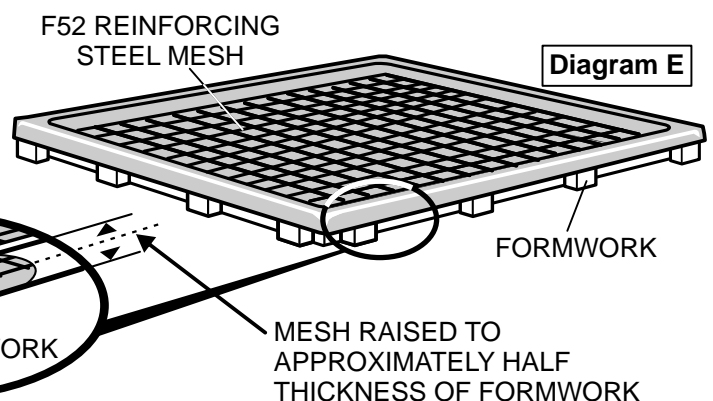
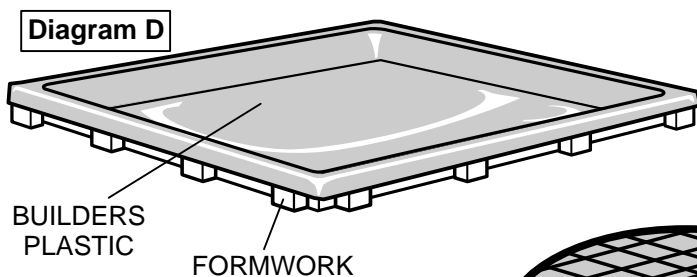
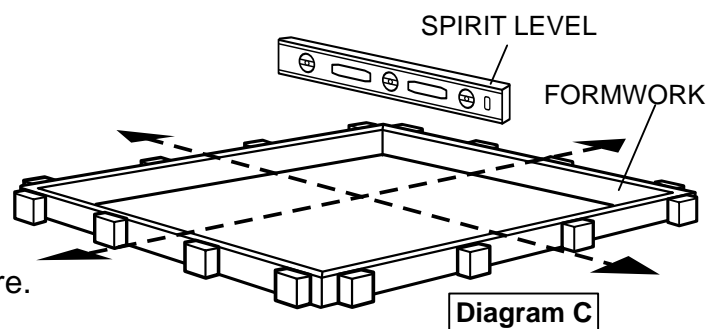

Pre-Assembly

FRONT TOP RAIL AND DOOR GLIDES

- (i) Slip the four rollers onto the four spindles of each of the four door glides as shown in Diagram 1.

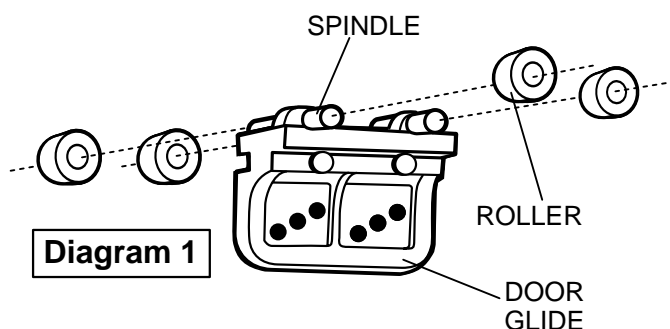

- (ii) Slide the four door glides with rollers attached, into the slot under the front top rail.

Hint: Front top rail is the longest of the three aluminium rails.

IMPORTANT: Make sure rollers don't slip off.

Note: The door glides **MUST** be positioned with the **CURVED** side facing the **FRONT** face of the top rail as shown. See Diagram 2.

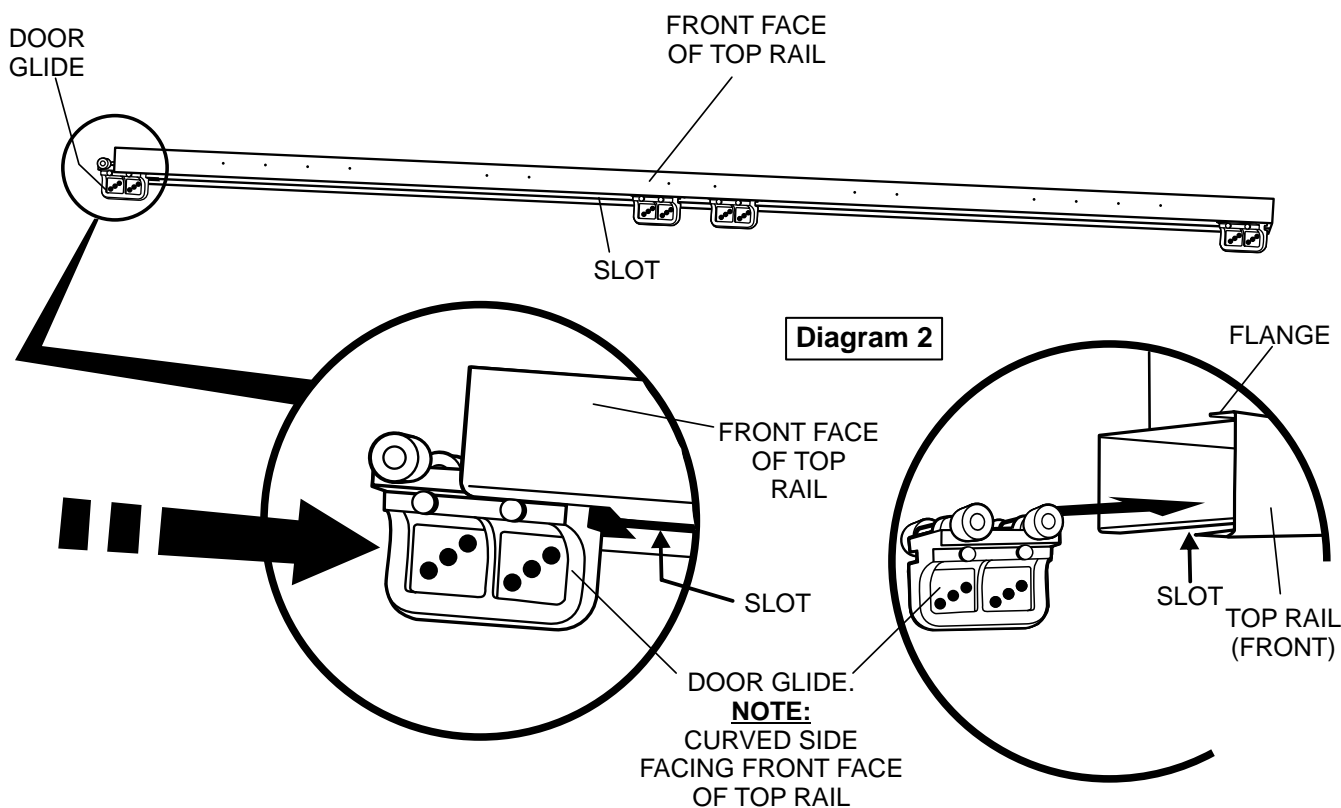

Pre-Assembly

RIGHT AND LEFT SIDE TOP-WALL RAILS

- (i) Using one of the top-wall rails, slide the corresponding top-wall rail brackets into each end as shown in Diagram 3 below. Then secure each end with a screw as shown.
- (ii) Repeat using remaining top-wall rail and the two top-wall rail brackets.

IMPORTANT:

Both side top-wall rails have a sharper angle at one end as shown in Diagram 3A. Each of the top wall-rail brackets has a wide and narrow section and **MUST** be inserted as shown in Diagram 3.

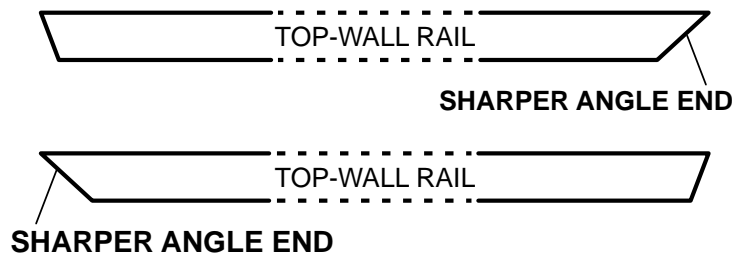
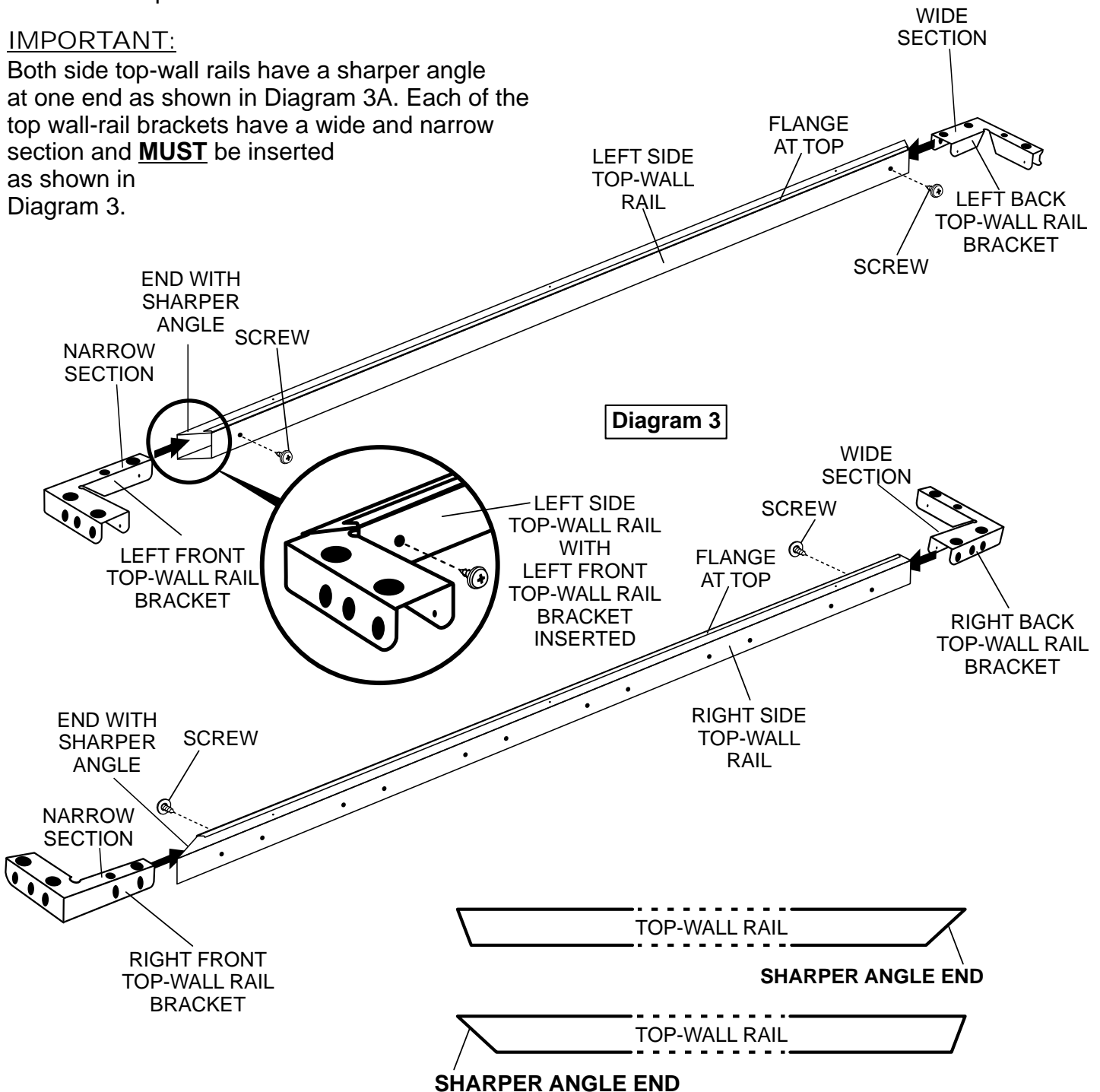

Pre-Assembly

SLIDING DOORS

NOTE: Assemble doors on a clean flat surface.

- (i) Attach door braces as shown in Diagram 4, by sliding the underside of the brace under the door edge, so the underside of the front face of the door brace is seated onto the front face of the door panel. Secure using nuts and bolts ONLY IN HOLES AS SHOWN.

IMPORTANT: Ensure elongated holes in braces match elongated holes in doors.

- (ii) Attach two door spacers to the bottom of each door as shown below.
- (iii) Attach one door handle to each door as shown.

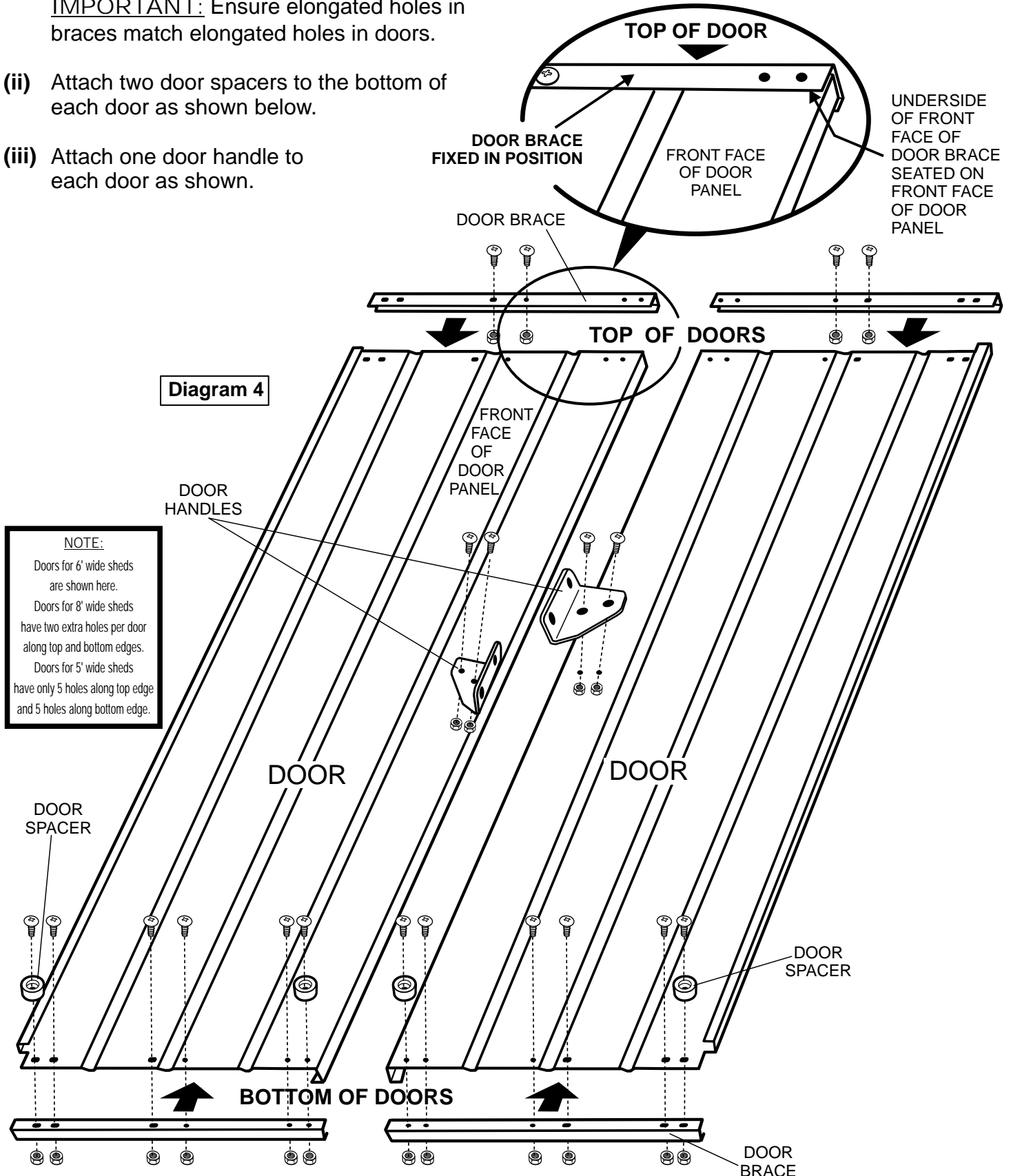

NOTE:
 Doors for 6' wide sheds are shown here.
 Doors for 8' wide sheds have two extra holes per door along top and bottom edges.
 Doors for 5' wide sheds have only 5 holes along top edge and 5 holes along bottom edge.

Garden Shed Construction

Step 1 Refer to Diagram 1

Note: Familiarise yourself with the profile of each base rail.

IMPORTANT: The small holes on the vertical (side) faces of each base rail MUST face outwards.

Fix two side base rails to the front base rail using two screws at each end.

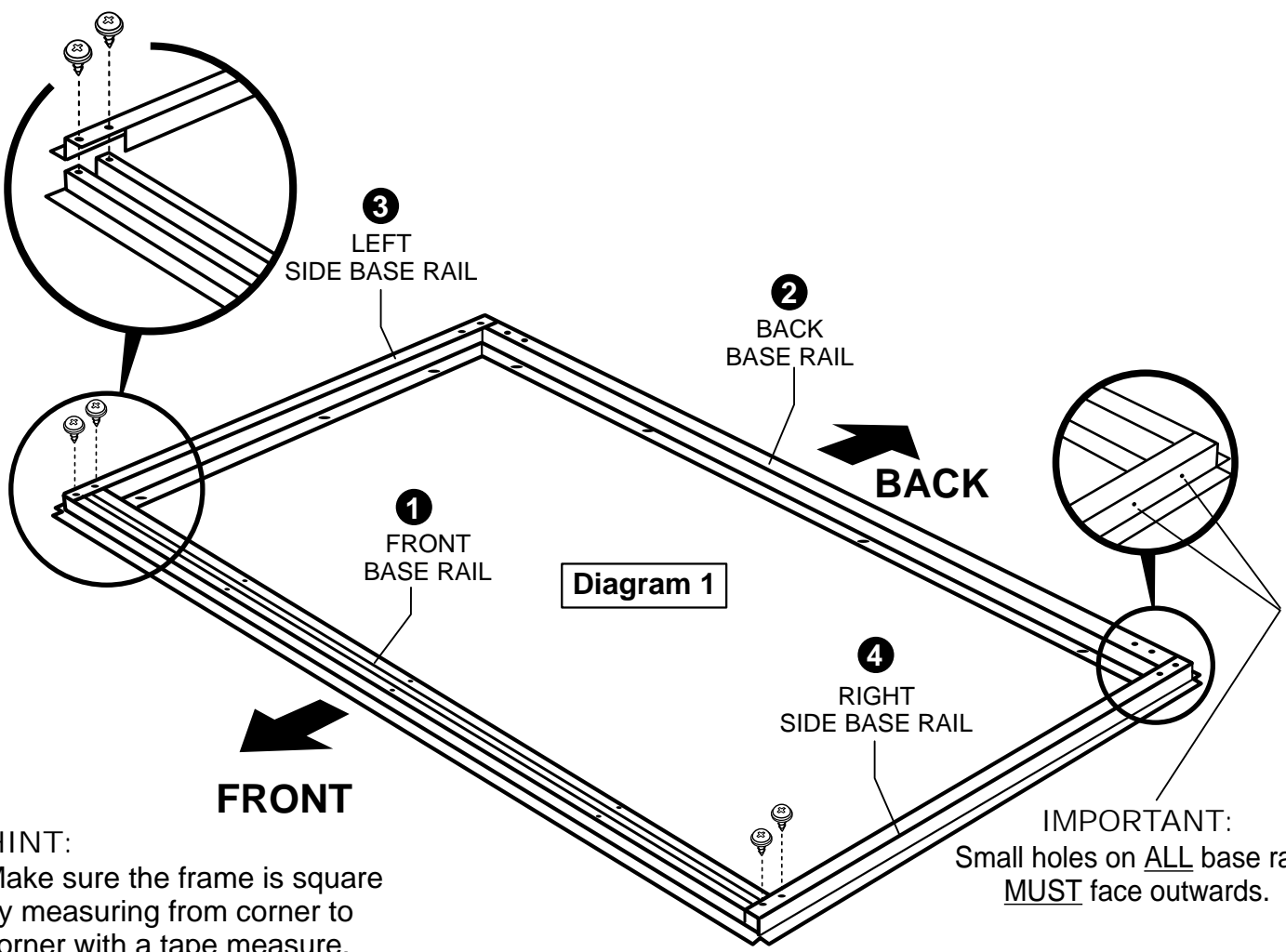

HINT:
Make sure the frame is square by measuring from corner to corner with a tape measure.

IMPORTANT:
Small holes on ALL base rails MUST face outwards.

Step 2

Attach corner braces to each end of the back base rail, and secure to side base rails as shown in Diagram 1A.

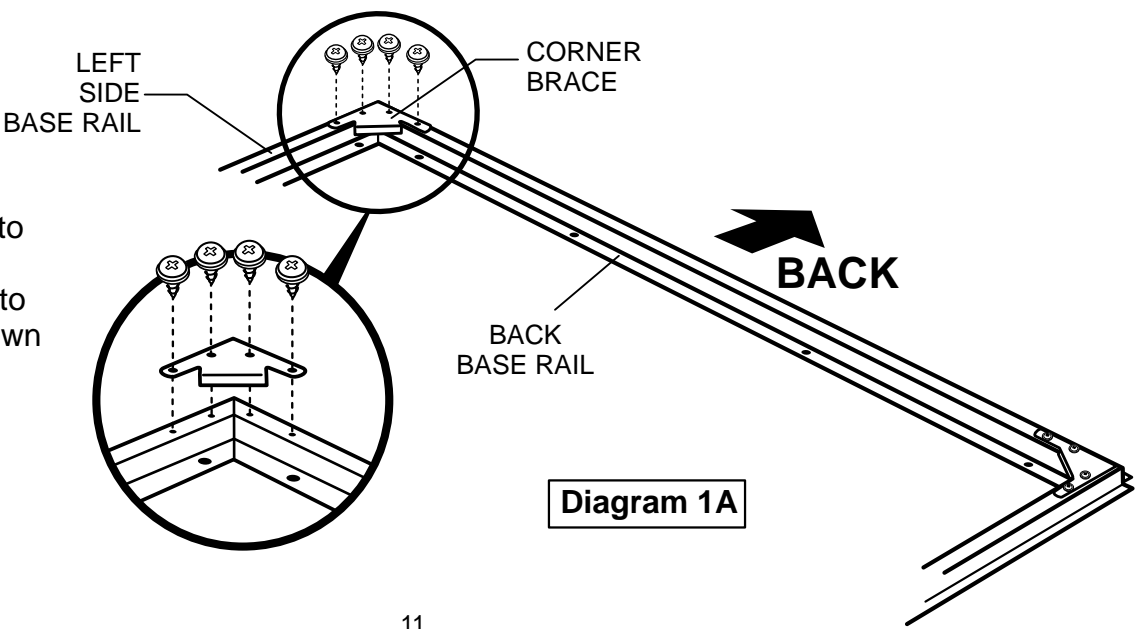

FORMING CORNER PANELS

IMPORTANT: Corner panels are supplied bent to a 135° angle. Bend all four panels to a 90° angle by following the instructions and diagrams to the right.

Lay the panel on a non-scratch surface and carefully form the angle to 90° by slowly working along the panel and bending it as you go. See Diagrams A - D.

IMPORTANT: DO NOT OVER BEND PANEL.

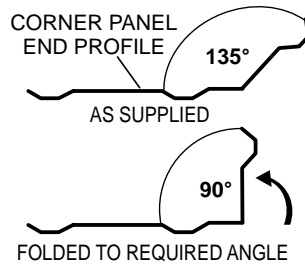

Diagram A

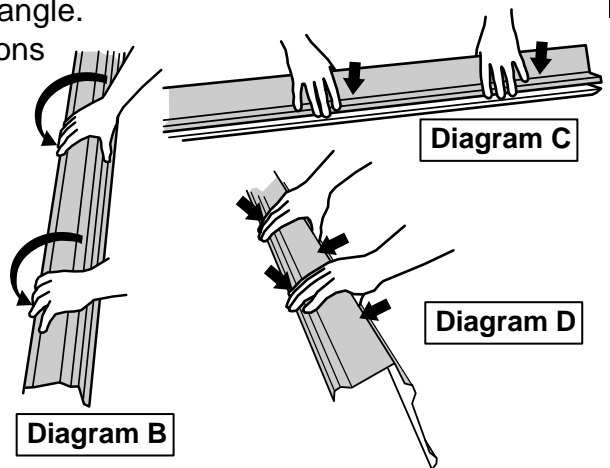

Diagram B

Diagram C

Diagram D

Step 3 FITTING CORNER PANELS

IMPORTANT: Throughout these instructions fit screws in the order shown (where applicable).

Fit one corner panel to the base rail outer edge in the FRONT RIGHT CORNER as shown in Diagram 2.

IMPORTANT: WIDER face of panel **MUST FACE FRONT**.

Secure with three screws in numerical order as shown in Diagram 2.

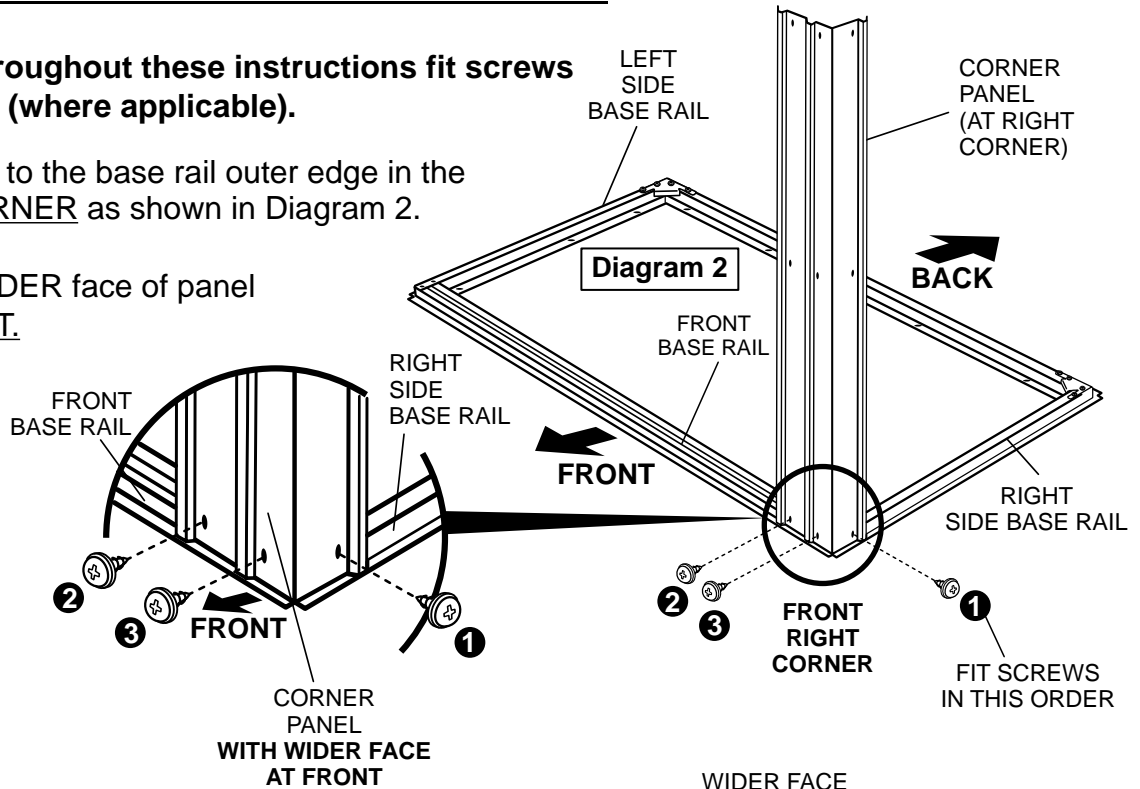

Step 4

Repeat the procedure for the second corner panel at the BACK RIGHT CORNER, ensuring WIDER face of the panel faces the BACK. See Diagram 3.

Then fit one side mid-wall brace to the two corner panels at the centre hole position, and secure using a screw at each end of the mid-wall brace. See Diagram 3.

IMPORTANT:

Holes at each end on the thin face of the side mid-wall brace **MUST** face upward.

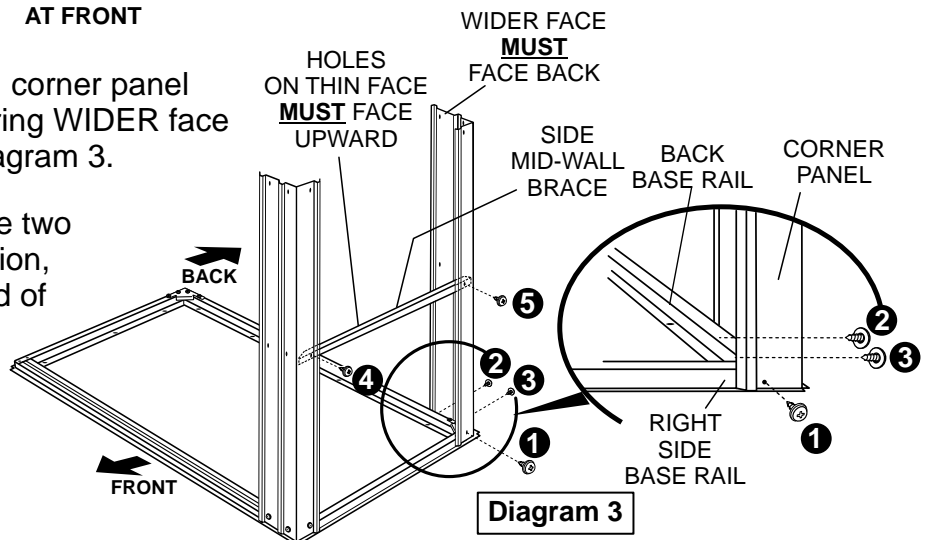
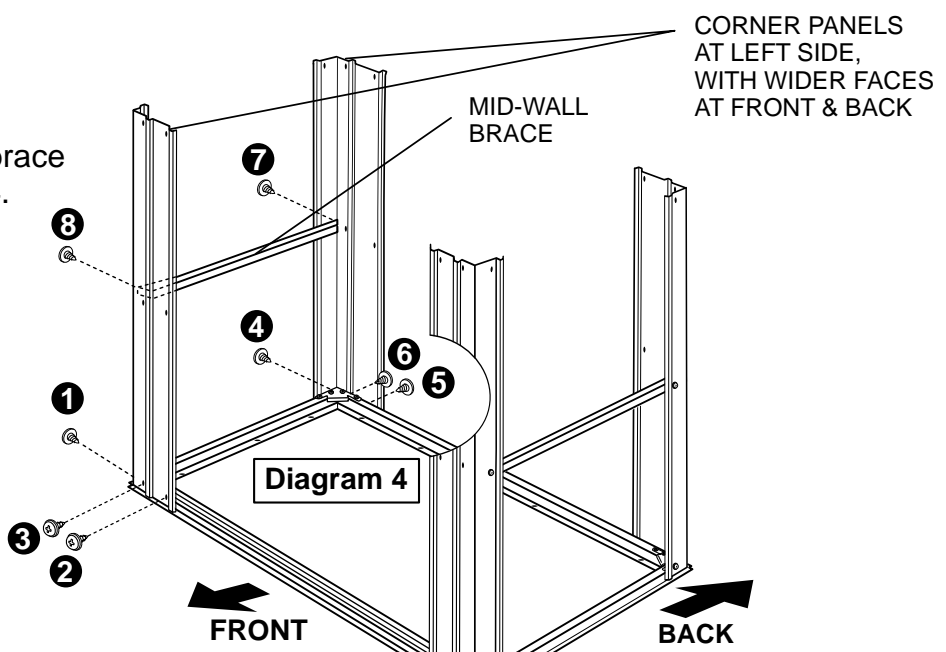

Diagram 3

Step 5

Repeat steps 3 and 4 for the two corner panels and mid-wall brace at the LEFT side. See Diagram 4.

IMPORTANT:
Ensure the wider faces of the corner panels are facing front and back.



Step 6

This step uses pre-assembled components.

Attach and secure both side top-wall (left and right) rail assemblies to the inside of the corner panels as shown, using one screw at each end of rail. See Diagram 5.

IMPORTANT:
The two faces of the side top rails, with multiple holes, **MUST** face outwards and top of shed.

IMPORTANT:
The ends of the side top-wall rail assemblies with the **WIDE** section brackets **MUST** be positioned at the **FRONT** of the shed, and the **NARROW** section brackets positioned at the back of the shed.

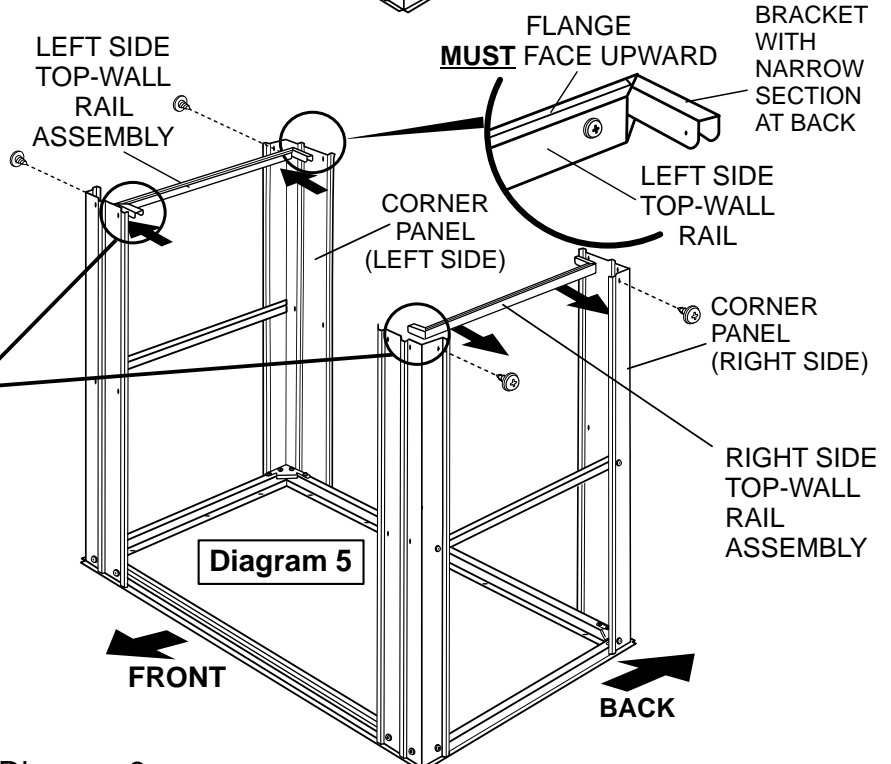

Step 7

Attach the **BACK** top rail as shown in Diagram 6.

IMPORTANT:
The two faces of the back top rail, with multiple holes, **MUST** face back and top of shed.

HINT:
Push the corner panels out slightly, to allow each end of the brackets to be inserted.

Secure using one screw at each end of the top rail, and secure top of both corner panels to back rail using two screws per panel, as shown in Diagram 6.

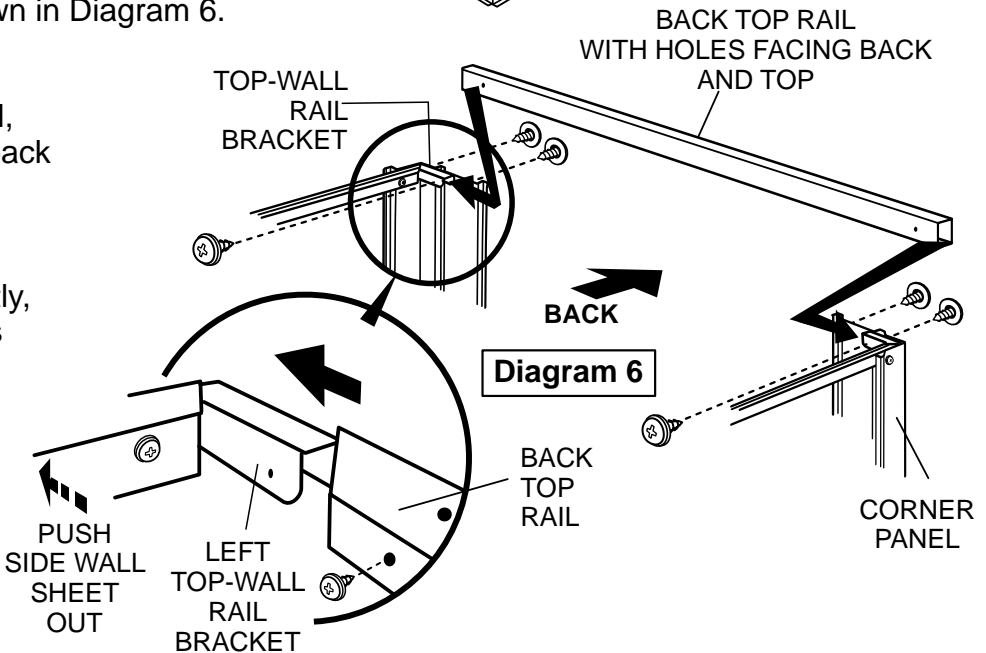

Step 8

This step uses a pre-assembled component.

Attach and secure the front top rail - **THE ONE WITH DOOR GLIDES** **INSERTED**, to the top-wall rail brackets at front, as shown in Diagram 7.

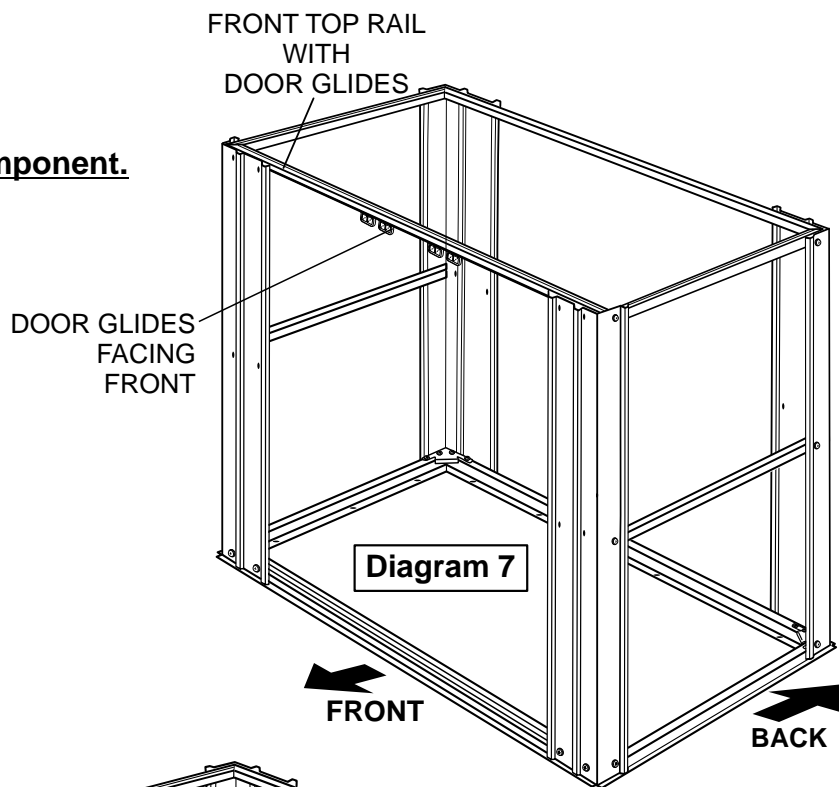

Step 9

Attach the back mid-wall brace to the inside of the **BACK** corner panels, at the centre hole position, using two screws at each end. See Diagram 8.

IMPORTANT:
Holes at each end on the thin face of the back mid-wall brace **MUST** face upward.

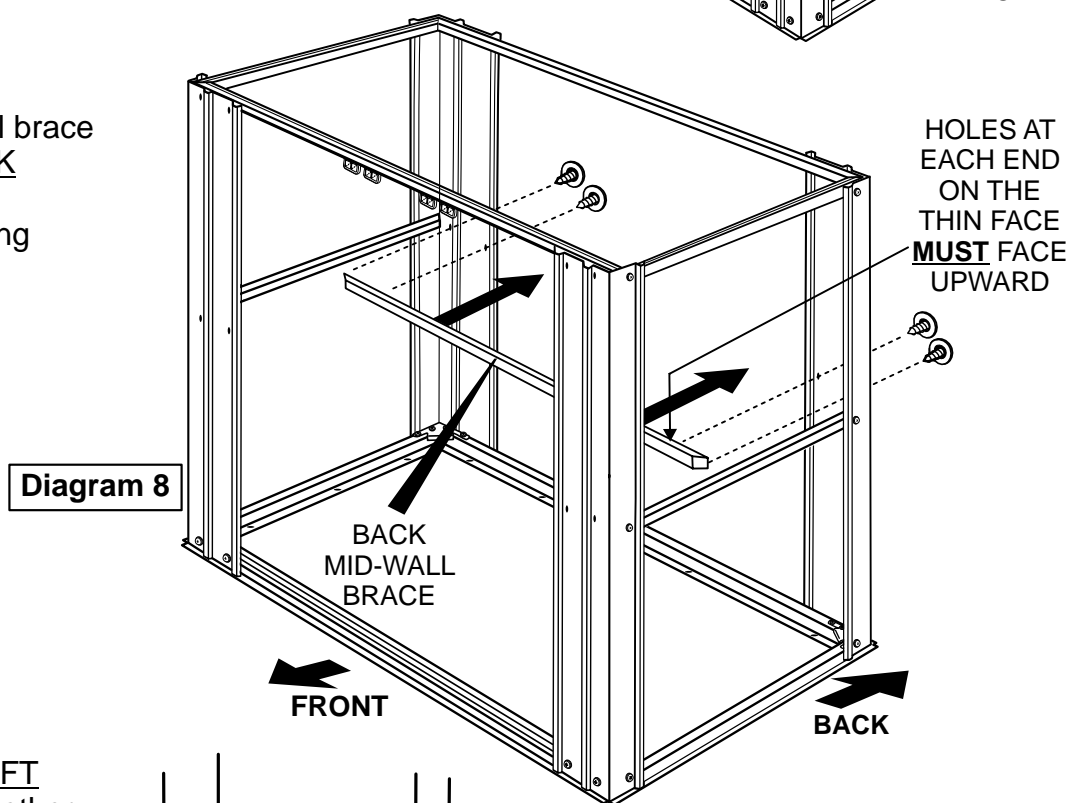

Step 9A

Secure the back and **LEFT** side mid-wall braces together using a corner brace and four screws as shown in Diagram 8A.

Repeat for right side.

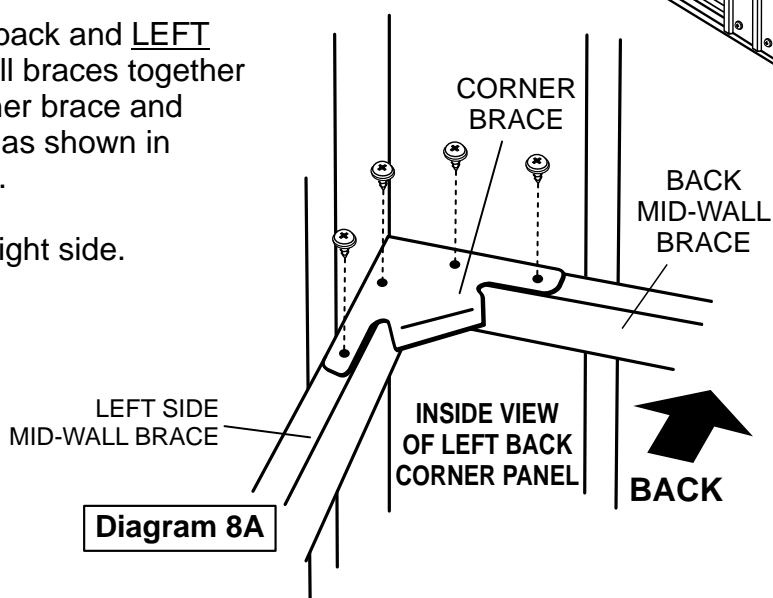

Step 10

ATTACHING THE FRONT FASCIA PANEL

IMPORTANT: If you are constructing an 8' wide shed go directly to Step 10A now.

5' & 6' wide sheds

Fit the front fascia panel to the FRONT top rail by sliding the bottom back edge of the fascia panel into the flange at the top of the front top rail. See Diagram 9.

Secure using six screws. See Diagram 10.

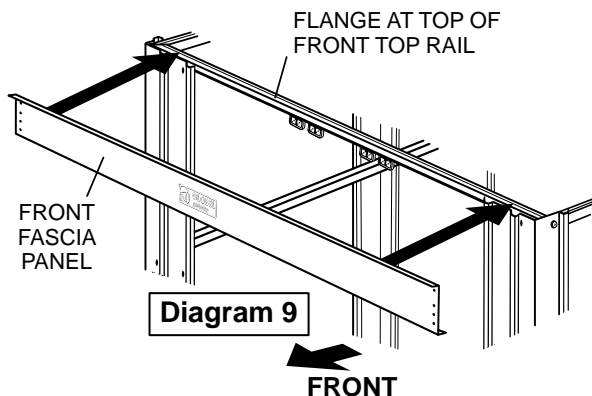

Step 10A

8' wide shed

IMPORTANT:

Ensure LEFT front fascia panel is positioned at LEFT side (when viewing from front of shed) and RIGHT front fascia panel is positioned at RIGHT side. The left and right panels can be identified by having no hole at the outside edge of the bottom flange. See Diagram 11.

Fit the left and right front fascia panels to the FRONT top rail by sliding the bottom back edge of one panel into the flange at the top of the front top rail and aligning it to the left side of the top rail. See Diagram 11.

Then repeat for the other panel, overlapping the holes at the centre. See Diagram 11.

Secure using eight screws into the top beam and four nuts and bolts in the centre overlapping holes of the front fascia panels. See Diagram 11.

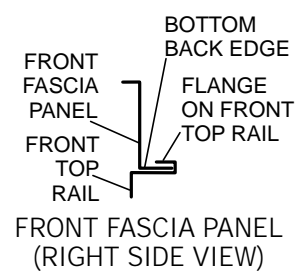
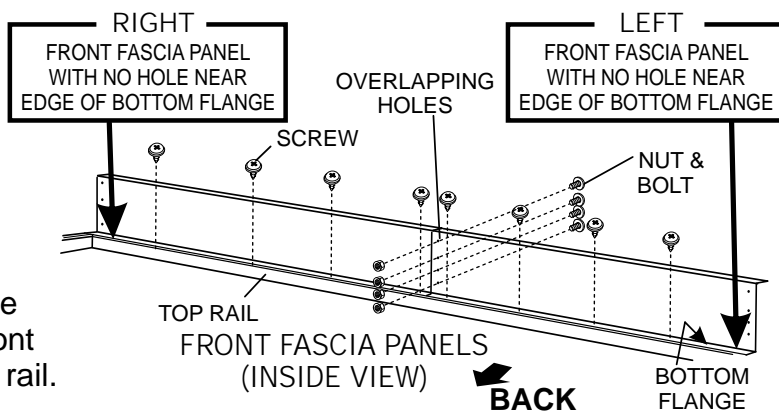
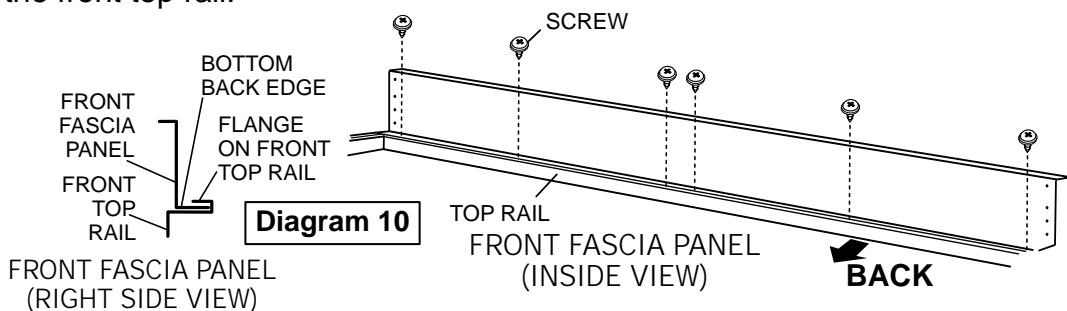

Step 11

ATTACHING THE 2 SIDE GABLES

Fit the left and right side gables to the side top-wall rails by sliding the inside bottom edge of the gable into the flange at the top of the side top-wall rail and secure using screws. See Diagram 12.

Secure to the front fascia panel using four nuts and bolts as shown.

NOTE FOR 3' DEEP SHEDS ONLY:

Only three nuts and bolts are required to join the gables to the front fascia panel in the corresponding far right and left corners. See Diagram 12.

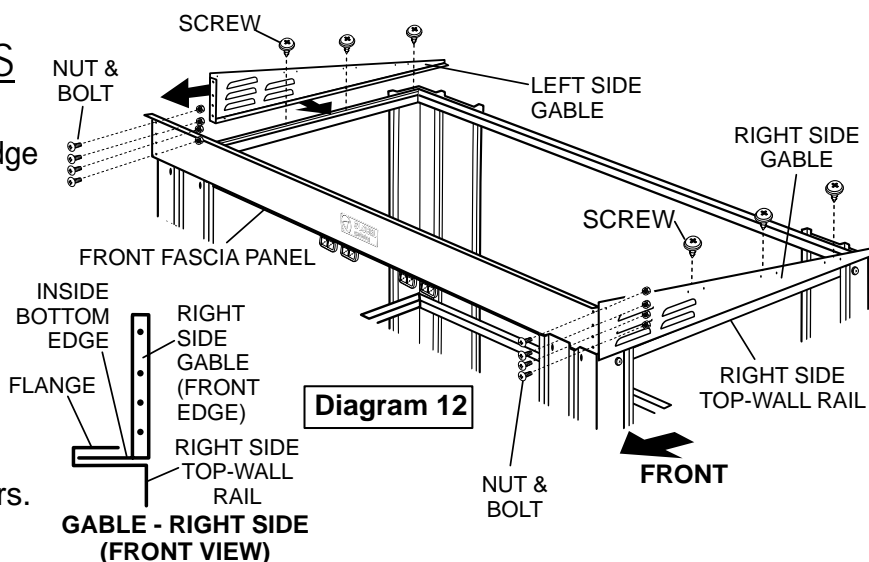

Step 12 FITTING WALL SHEETS

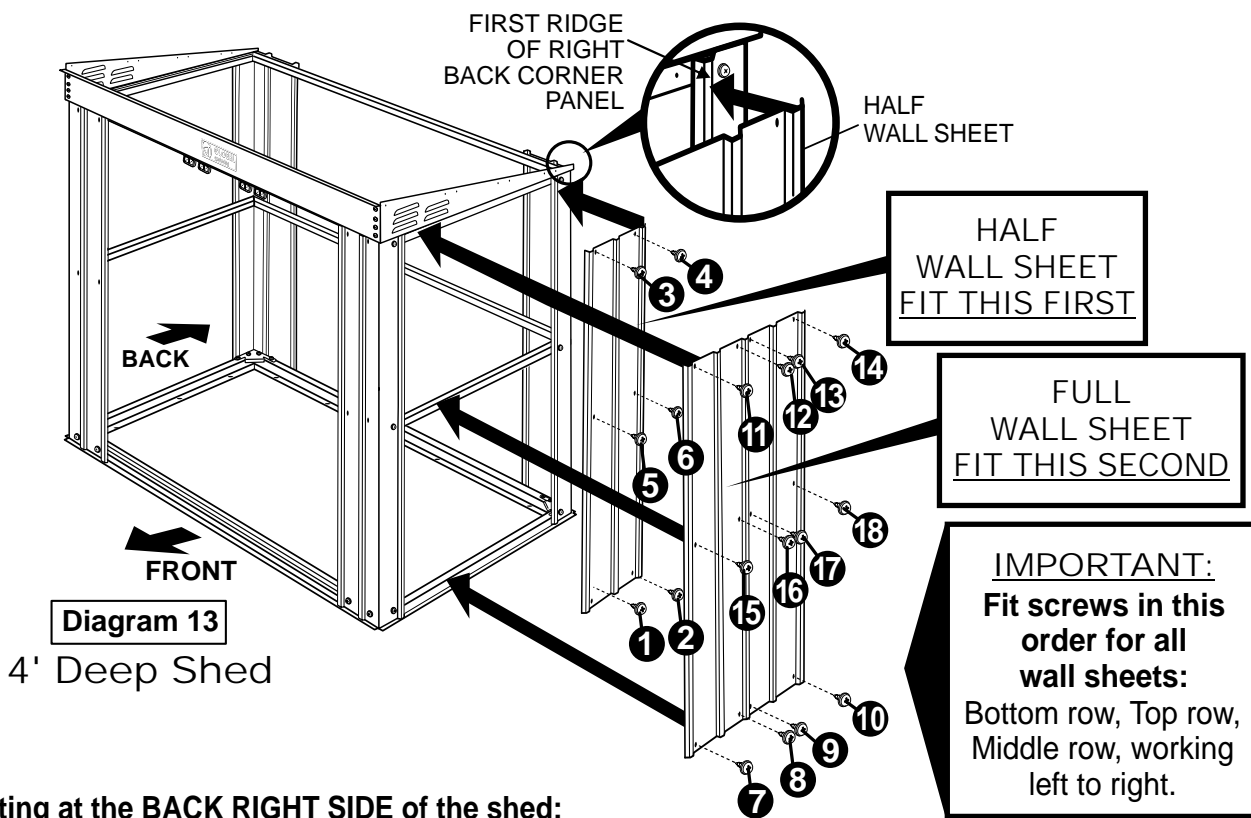

Diagram 13

4' Deep Shed

Starting at the BACK RIGHT SIDE of the shed:
 Refer to Diagrams 13 (4' deep shed) and 13A (3' deep shed).
 Fit one half wall sheet (or one full wall sheet, depending on the depth of your shed) overlapping the first ridge of the RIGHT BACK corner panel and secure to the bottom, top and middle rails/brace, using screws, and following the numerical order shown in both diagrams.

IMPORTANT:
READ BEFORE ATTACHING WALL SHEETS
FOLLOW STEP 12A and DIAGRAM 15 (SEE NEXT PAGE) for fitting the last wall sheet at the right side to the RIGHT FRONT CORNER PANEL.

Diagram 13A
 3' Deep Shed

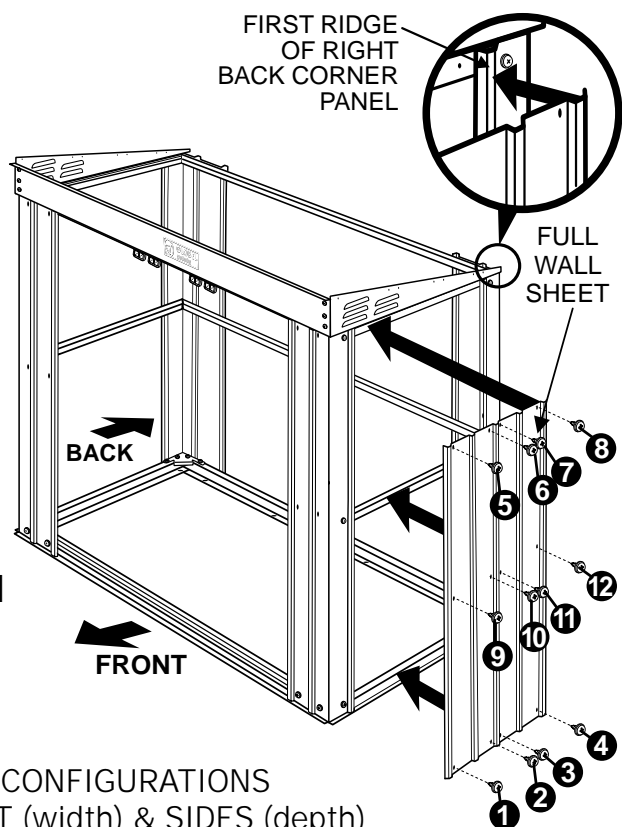

EXAMPLES OF WALL SHEET CONFIGURATIONS FOR 3 SHED SIZES - BACK & FRONT (width) & SIDES (depth)

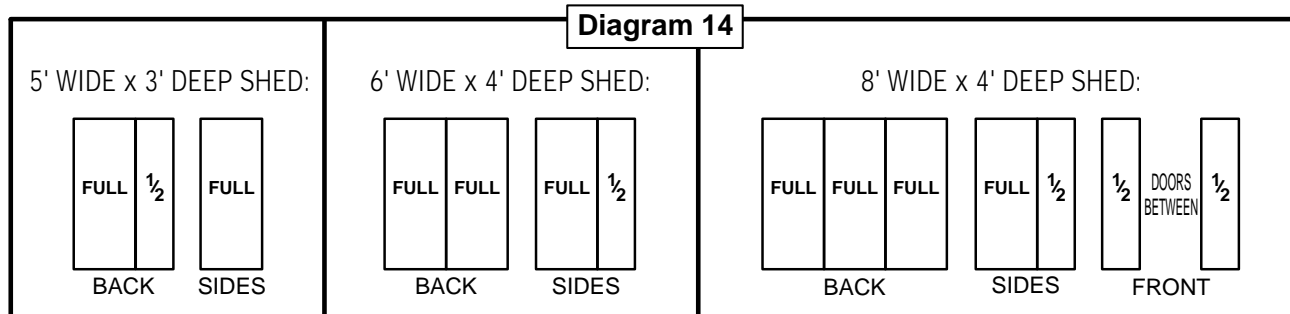

Diagram 14

Step 12A

FITTING SIDE WALL SHEETS TO FRONT RIGHT & LEFT CORNER PANELS.

NOTE: For aesthetics we recommend the full wall sheets underlap the sides of the front corner panels. This 'underlapping' creates the appearance of the shed wall being one continuous sheet.

Loosen off (but do not remove) the three screws along the side edge of the corner panels.
Then, by slightly prising the back edge of the corner panels away from the frame with your hand, slide the front edge of the wall sheets in behind.
See diagram 15.

Re-tighten the three screws in the corner panels and secure the wall sheets, using screws, in the numerical order shown in Diagram 13.

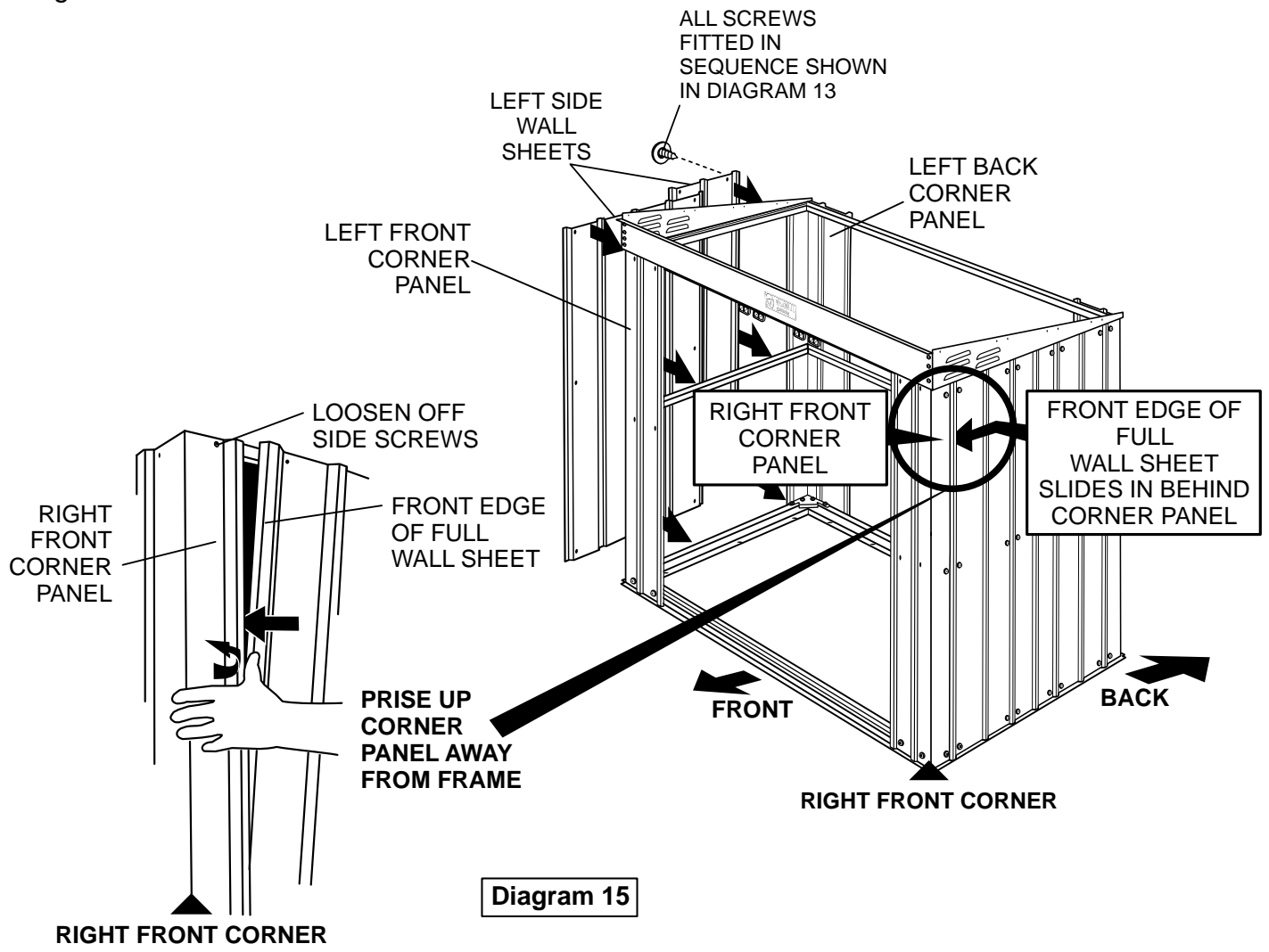

Step 12B

WALL SHEETS - BACK

Attach full wall sheets to the back of shed, starting at the RIGHT BACK corner panel and overlapping each sheet. Secure them with screws to the back bottom, top and middle rails/brace, in the same sequence as shown in Diagram 13. See Diagram 16.

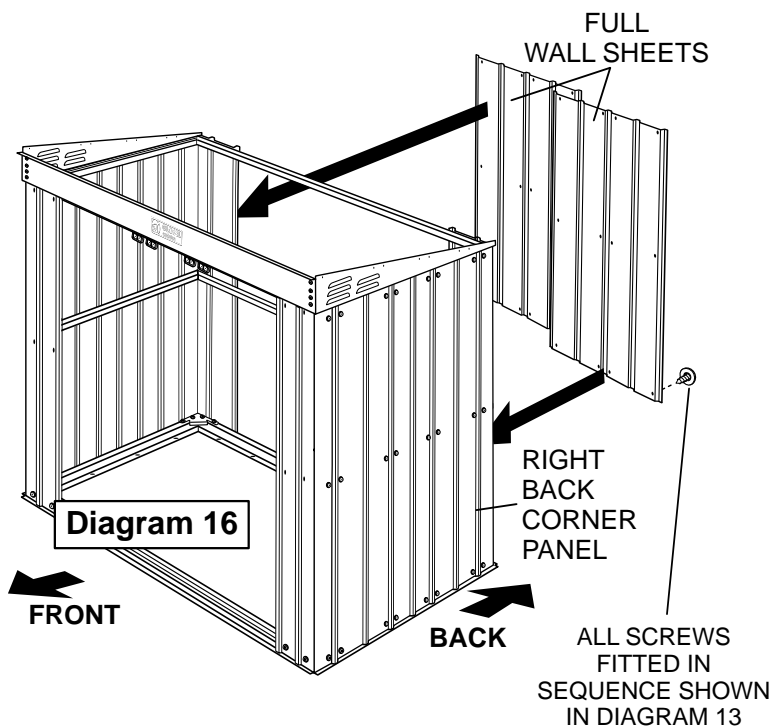

Step 13

Attach the left and right front mid-wall braces to the inside corner panels, securing with two screws in each side as shown in Diagram 17.

HINT: The left and right front mid-wall braces can be distinguished by the position of the holes on the vertical and top faces.

See Diagram 17.

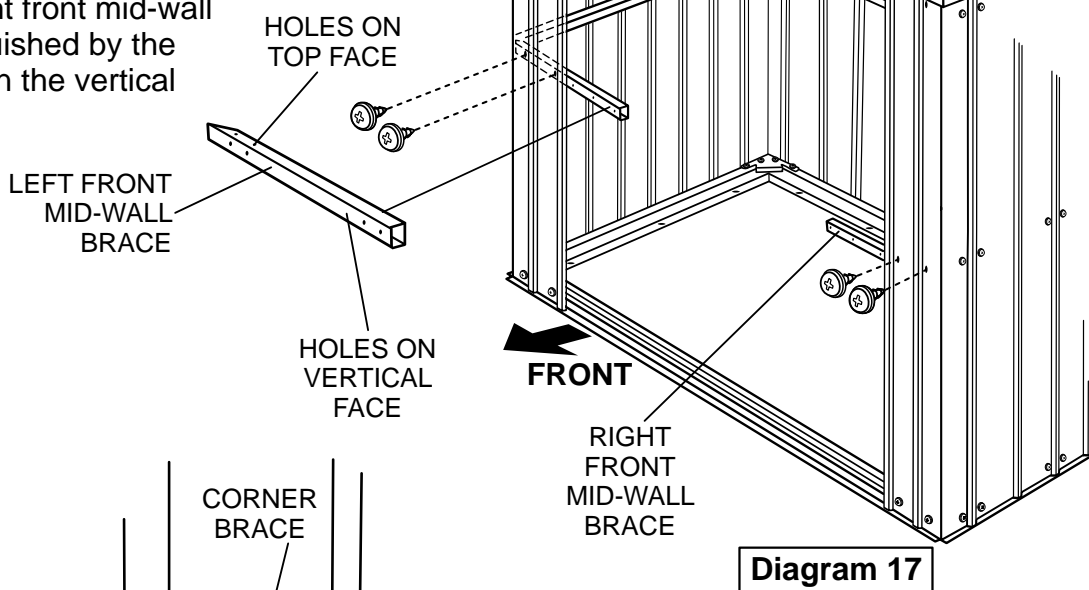

Step 14

Secure the right front and side mid-wall braces together using a corner brace and four screws as shown in Diagram 18.

Repeat for left side.

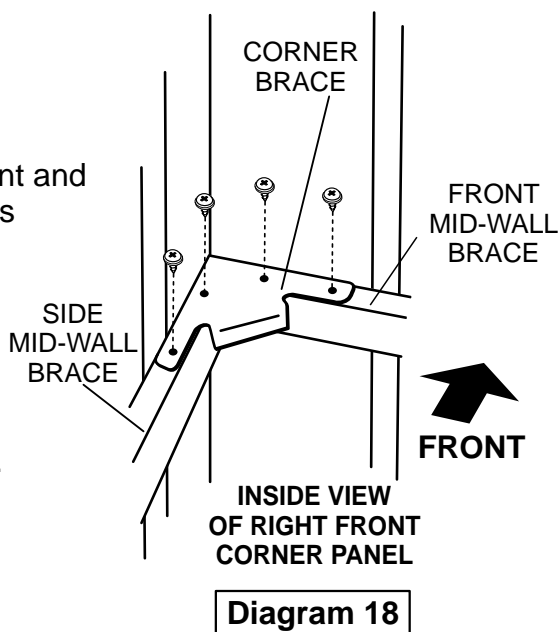

Step 15 FITTING DOOR JAMBS (AND FRONT WALL SHEETS WHERE APPLICABLE)

NOTE: FRONT WALL SHEETS are **ONLY** relevant to **8' wide sheds** and **MUST** be attached prior to the door jambs. Refer to Page 16, Diagram 14 to see which size wall sheet applies to the shed size you are assembling.

IMPORTANT: If you are **NOT** assembling an **8' wide shed**, go directly to Step 15A now.

WALL SHEETS - FRONT

Fit the front left and right wall sheets to the corner panels by slightly prising up the edges of the corner panels and sliding the wall sheets under, as shown in Step 12A, Diagram 15, Page 17. Secure using screws and follow the numerical order shown in Diagram 13, page 16. See Diagram 19.

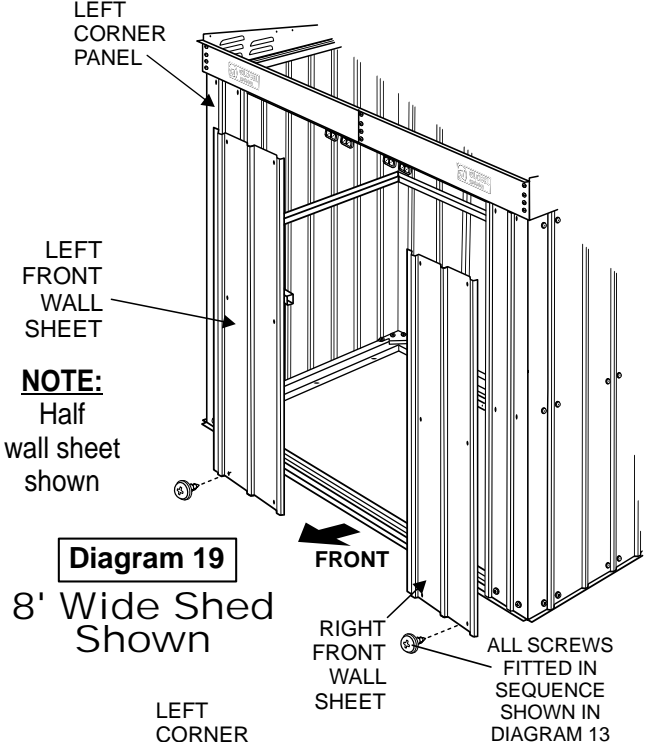

Step 15A DOOR JAMBS

Attach one of the door jambs to the front corner panels (for 6' wide sheds) or the front sheet (for 8' wide sheds) by slightly prising up the edges of the corner panels or front wall sheets and sliding the door jambs under, as shown in Step 12A, Diagram 15, Page 17.

NOTE: Door jambs for 8' wide sheds are different in shape to those shown in Diagram 19A.

FOR 6' WIDE SHED:

Secure with three screws in the bottom of the door jamb, two screws (**ONLY**) in the top of the door jamb and three screws in the front mid-rail. See Diagram 19A.

FOR 8' WIDE SHEDS:

Secure with two screws in the bottom of the door jamb, one screw (**ONLY**) in the top of the door jamb and two screws in the front mid-rail.

IMPORTANT - ALL Shed Sizes:

Leave top inside hole empty, as shown in Diagram 19A

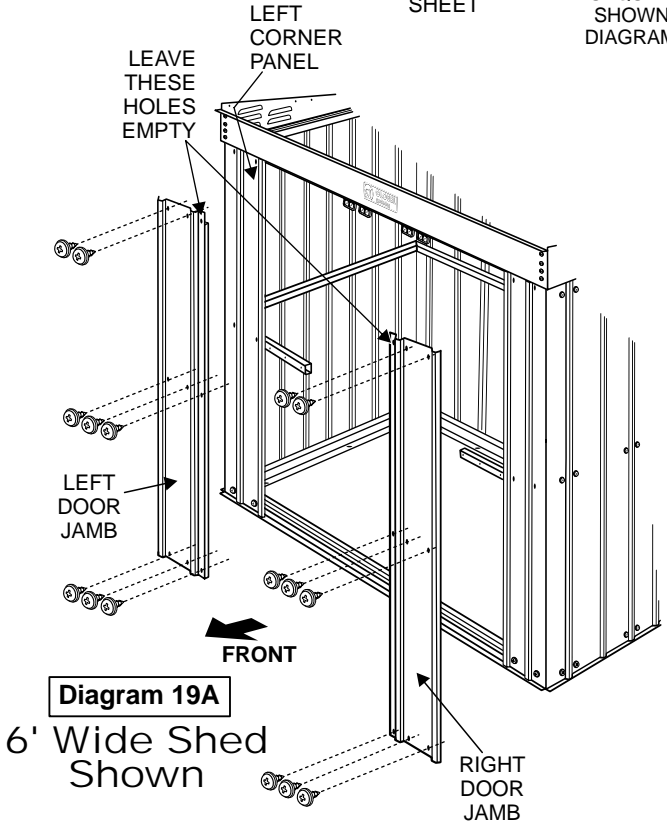

Step 16

Attach the entry/exit ramp to the front base rail, and secure using six screws. See Diagram 20.

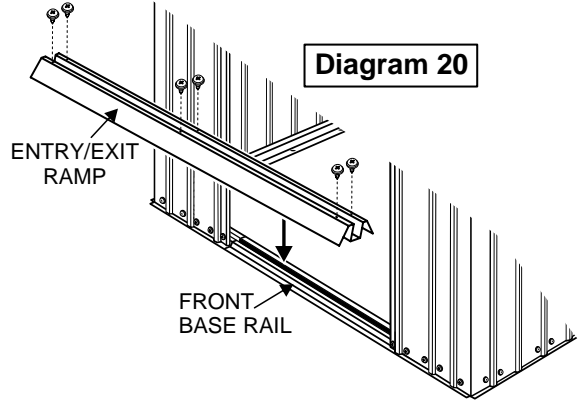

Step 17

ROOF STARTERS & SHEETING

IMPORTANT:

For the roof starters and sheeting, every screw and bolt must have a washer.

NOTE:

Nuts and bolts fitted upside down along the front top edge of roof starters and roof sheets to front fascia must have the washers placed under the nut.

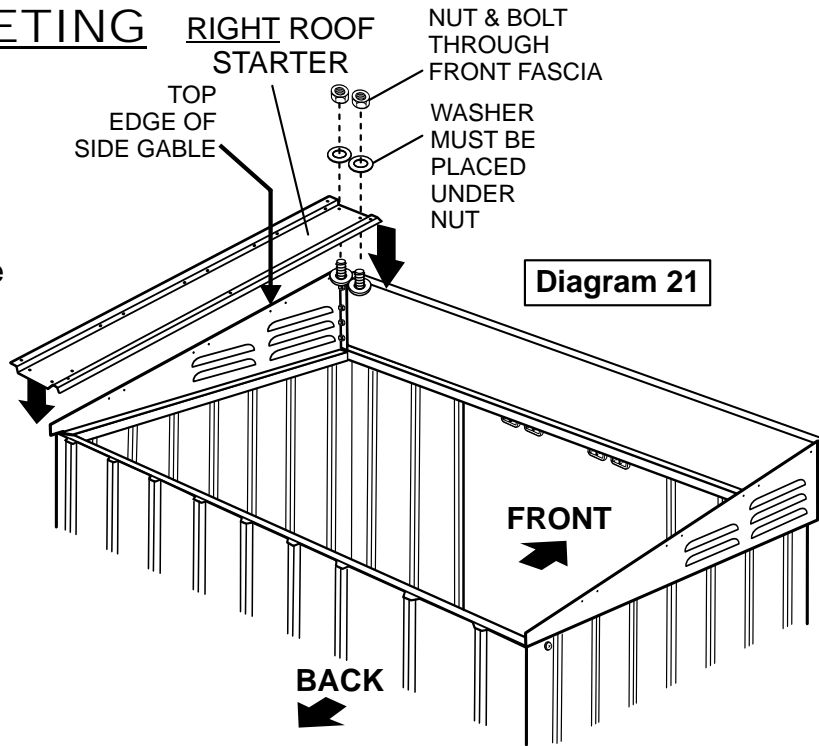

ROOF STARTERS

Fit the RIGHT roof starter to the top edge of the RIGHT side gable and secure to the top of the front fascia using two nuts and bolts in the positions shown in Diagram 21.

IMPORTANT:

Insert bolts from the bottom. Place washers under nuts.

Step 17A

Secure the RIGHT roof starter to the side gable assembly using six nuts and bolts with washers, in the holes along the vertical edge of the roof starter. See Diagram 22.

IMPORTANT:

NUTS AND BOLTS **MUST** BE INSERTED AS SHOWN

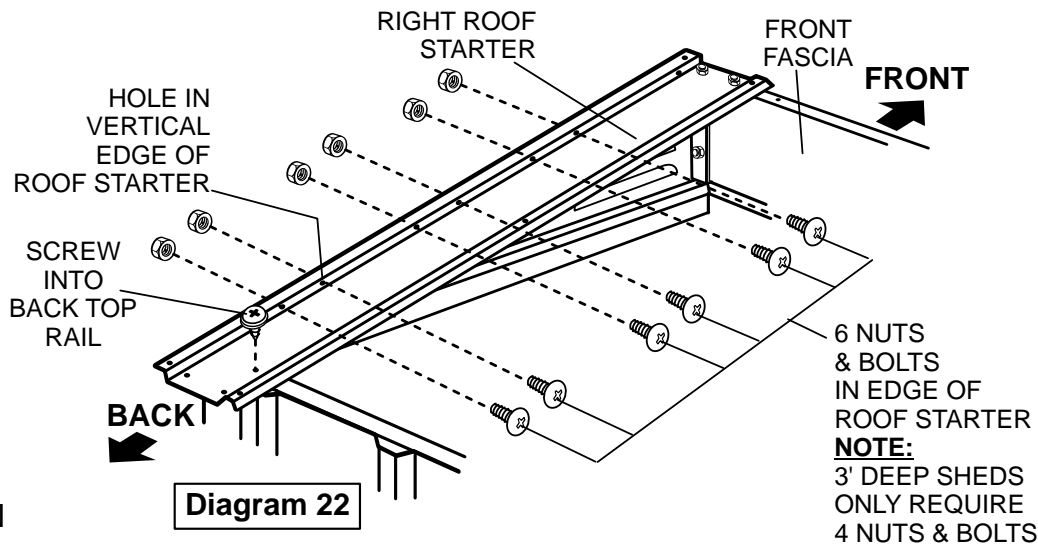

Then fit a screw in the hole near the bottom of the roof starter and into the top edge of the back top rail as shown in Diagram 22.

Repeat procedure for left side roof starter. See Diagram 23.

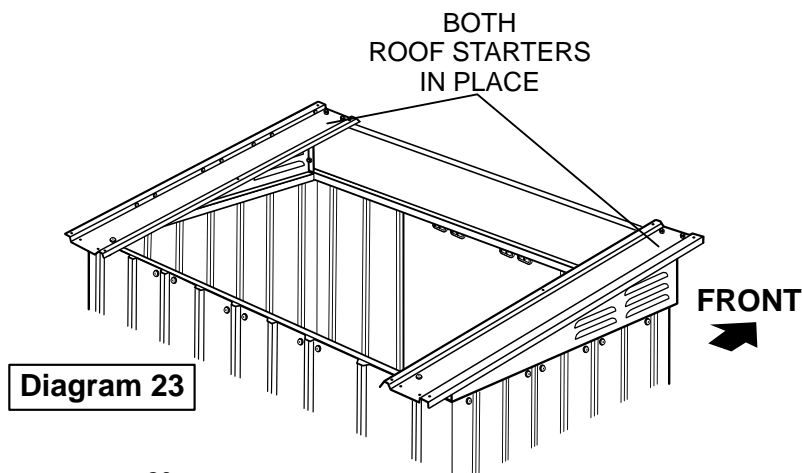

Step 18

Refer to Diagram 24 and fit roof sheets in the sequence shown in the "Roof Sheet Installation Number Sequences" Diagram at the bottom of this page, ensuring they are the correct way up, and the side edges overlap the corresponding roof starters.

First, secure the front edge to the top of the front fascia panel using nuts and bolts as shown in Diagram 24.
NOTE: insert the nuts and bolts from the bottom and place the washers under the nuts.

Then secure the back and side edge using screws, nuts and bolts as shown in Diagram 24.
NOTE FOR 3' DEEP SHEDS ONLY: Nut & bolt into side edge is **NOT** required.

Continue fitting sheets using screws, nuts and bolts, depending on the roof sheets used (full or half). See Diagram 25.

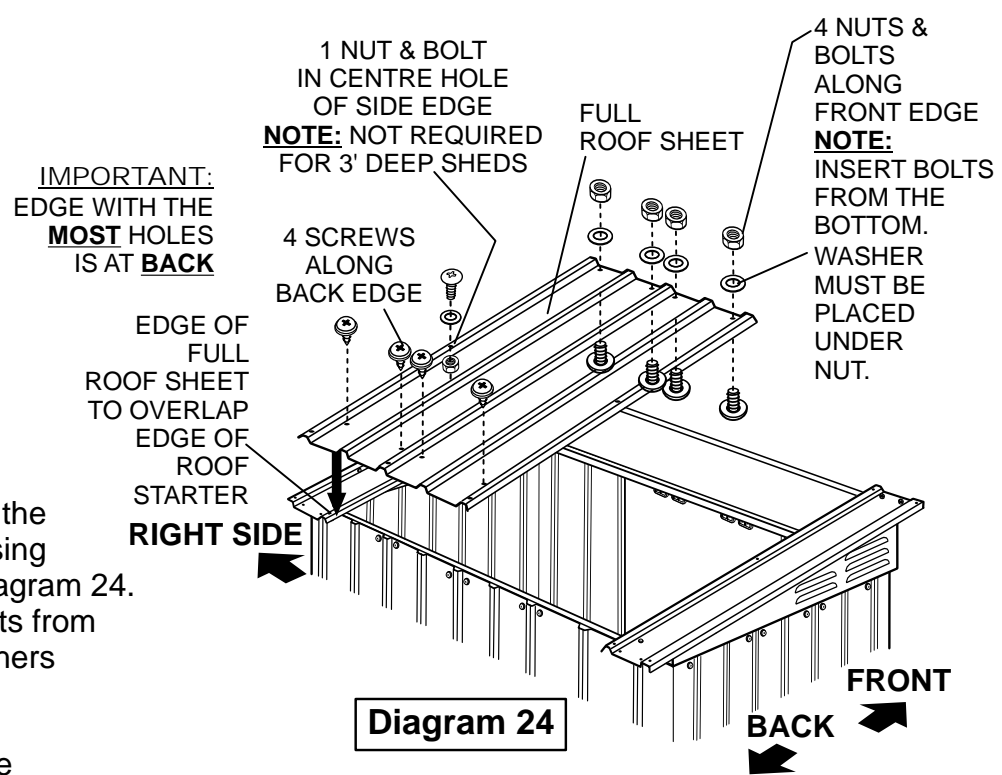

Diagram 24

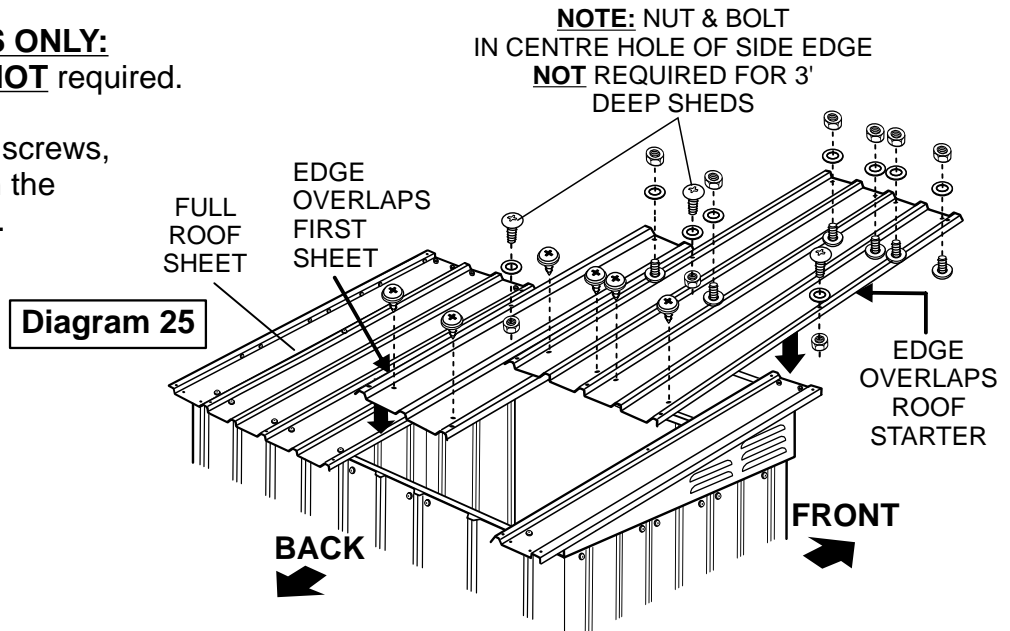
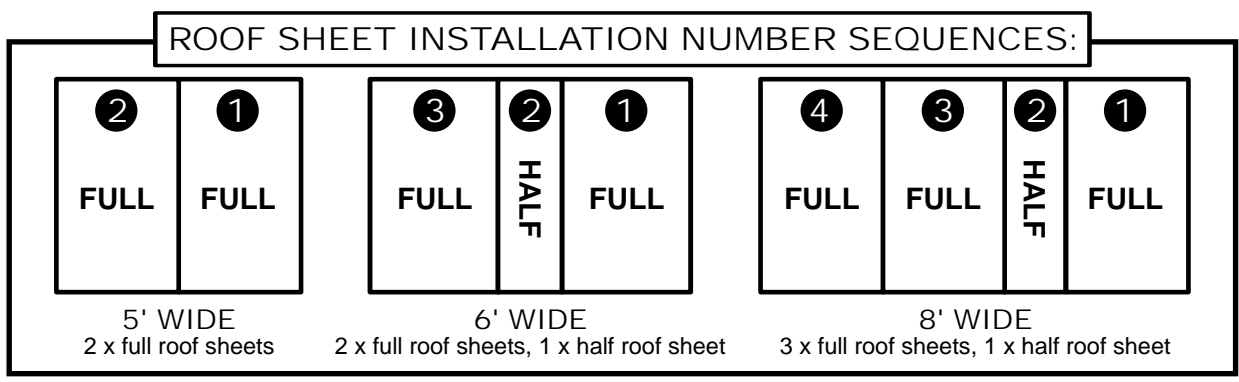

Diagram 25



Step 19

FITTING FRONT AND BACK ROOF TRIMS

IMPORTANT:

Back roof trims for 6' and 8' wide sheds require four nuts and bolts, back roof trim for 5' wide sheds require three nuts and bolts. See Diagram 26 and 26A.

Attach the roof trims to the front and back edges of the roof sheets as shown in Diagram 26, by sliding the bottom edge of the roof trims under the edge of the roof sheets so the underside of the top edge of the roof trims are seated on the top face of the roof sheets. Secure using one screw, and nuts and bolts ONLY IN HOLES AS SHOWN.

IMPORTANT:

FRONT ROOF TRIM - ALL SIZES:

Using a 3mm steel drill bit, drill a pilot hole at the centre hole of the FRONT roof trim and into the roof sheet. Then fit a screw.

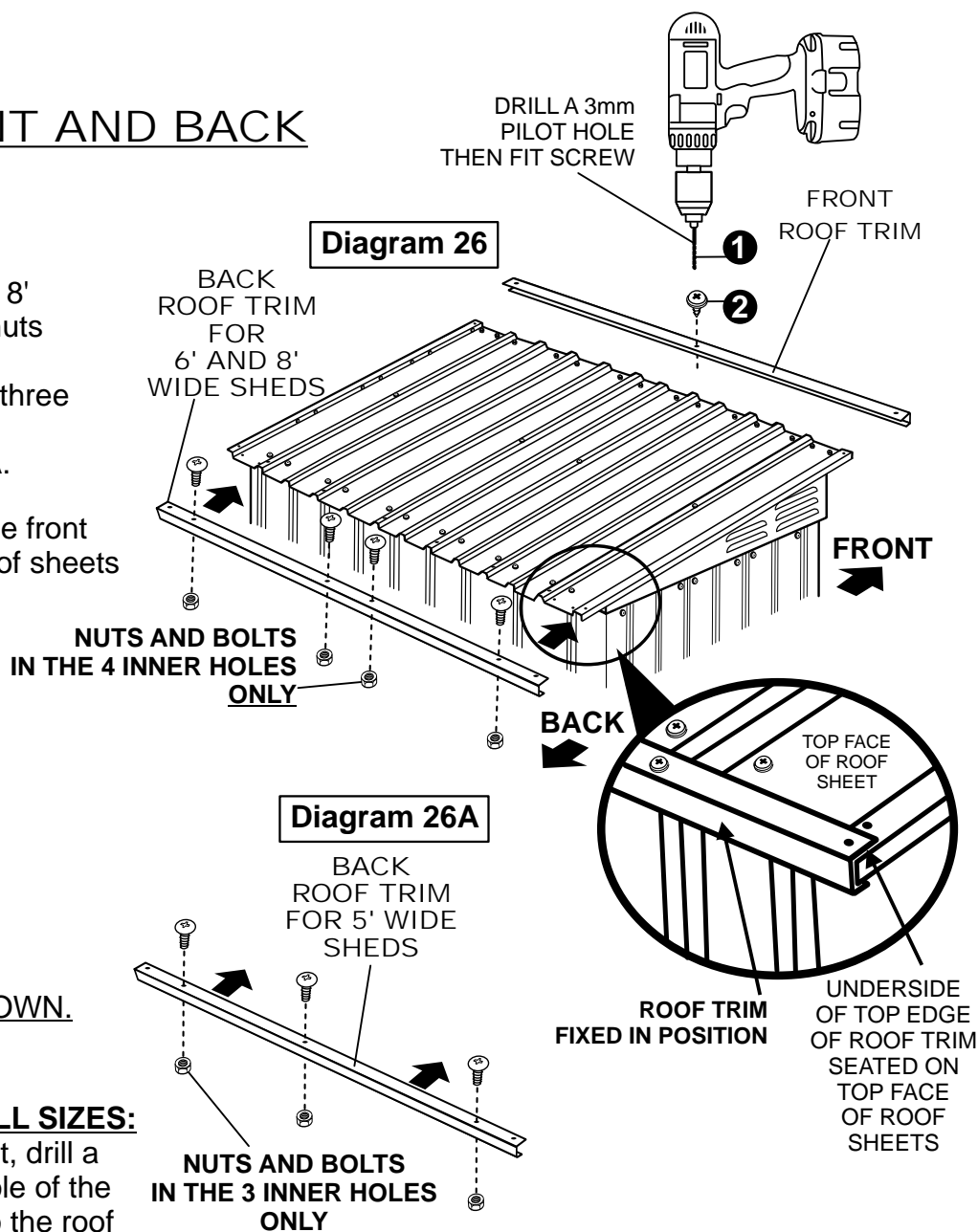

4 ROOF CORNER CAPS IN PLACE

Step 20

Fit the four roof corner caps to the left and right ends of both roof trims and secure with nuts and bolts as shown in Diagram 27.

NOTE:

Roof corner cap fits OVER roof trim. Washers are not required for this step.

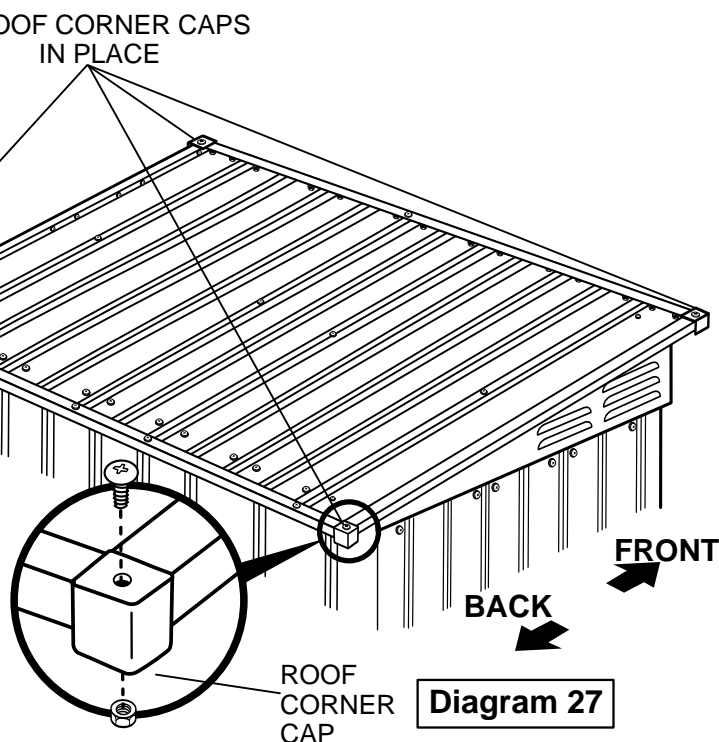

Step 21

FITTING SLIDING DOORS

This step uses pre-assembled components.

Start by fitting **LEFT** side door:

IMPORTANT:

Work from the outside of the shed with the front face of the door facing you and the door handle at the right side.

Taking the left door panel, tilt the top edge into the shed and under the door glides, as shown in Diagram 28. Then slot the bottom of the door into the groove in the entry/exit ramp as shown in Diagram 28A.

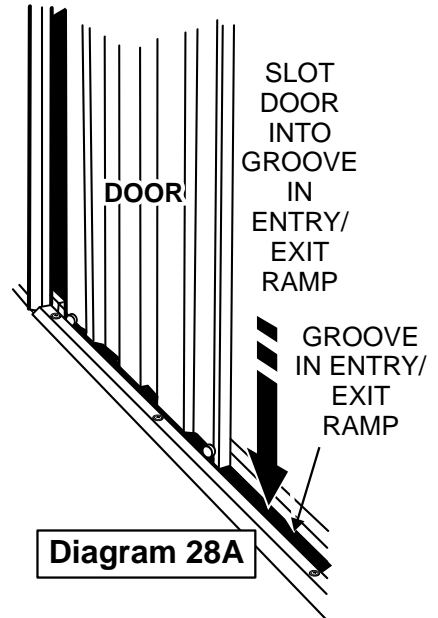
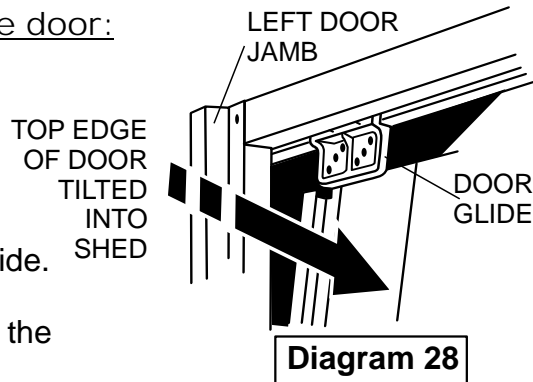

Step 22

(i) Attach the top of the door to the **FAR LEFT** door glide by securing with one nut and bolt in each of the **CENTRE** holes of the door glide and through the holes at the top **LEFT** of the door, as shown in Diagram 29.

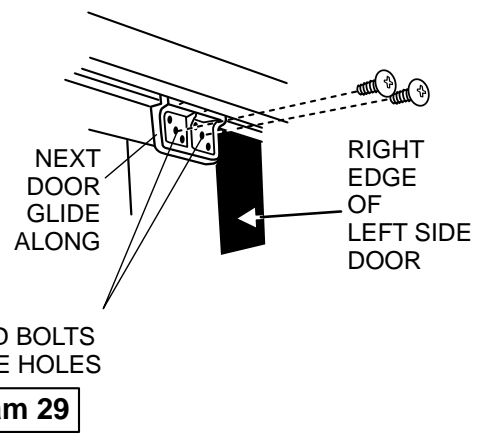
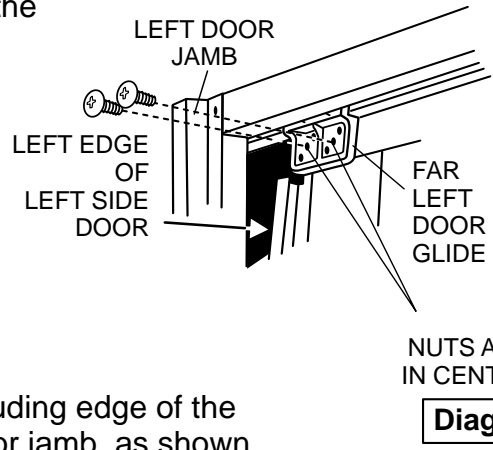

(ii) Repeat the procedure for the next door glide along, and secure it to two holes in the top right of the door.

(iii) Gently push the left protruding edge of the door in behind the left door jamb, as shown in Diagram 30.

(iv) Repeat the procedure (i to iii) for the right side door.

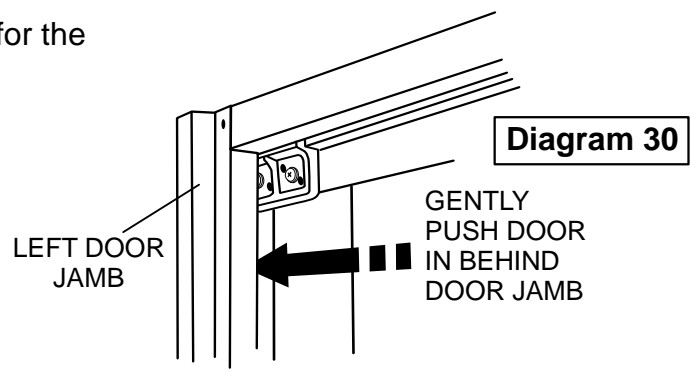

Step 23

DOOR ADJUSTMENT

When both doors are closed, they should be parallel at the centre. If not, adjust the position of one of the bolts in the relevant door glide to either raise or lower the edge of the door to make it parallel with the edge of the other door.

HINT: Extra holes are provided to align door if required. See Diagram 31.

RECOMMENDATION

In most cases, only a small adjustment is required by lifting or lowering the door slightly, which can be achieved without moving the bolt to another hole, but by simply loosening the bolts in the door glide and adjusting to suit, then re-tightening.

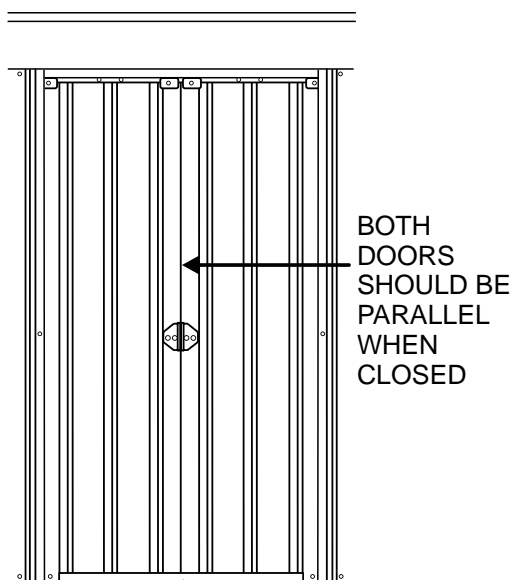
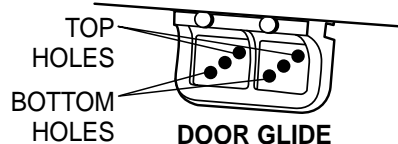

Diagram 31



Step 24

Fit the door fascia panel to the front top rail, using four screws as shown in Diagram 32.

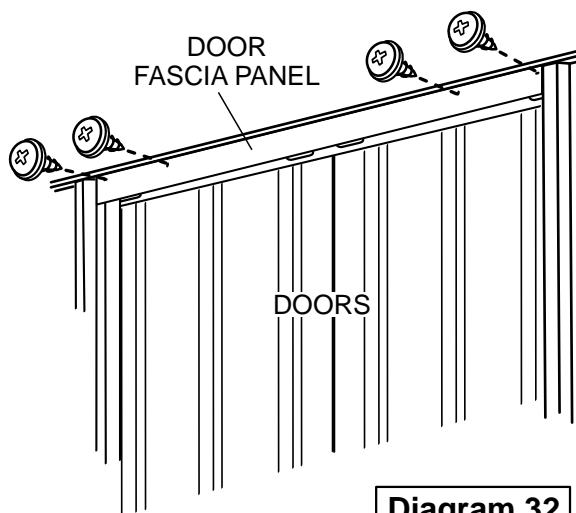

Diagram 32

Additional Notes

SLIDING DOORS:

SUGGESTION - Lubrication of Doors:

Spraying a silicone spray into the slot under the front top rail and along the inside face of the internal front mid-wall brace, will assist in a smoother and quieter operation of sliding doors.

REPLACEMENT OF DOOR GLIDES:

Remove nuts and bolts from door glide(s) to be removed, and slide in direction away from handle side of door. Door glide will drop out from far end of slot under front top rail. Replace door glide by inserting into slot under front top rail, slide into position and secure with nuts and bolts. See diagram shown.

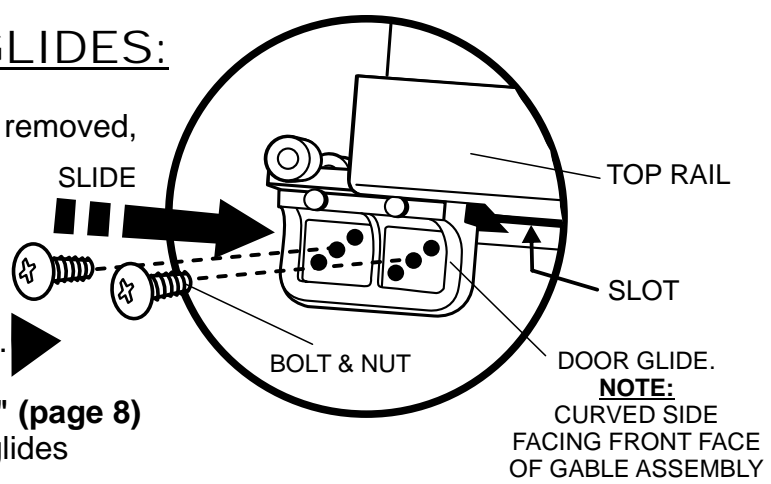

Refer to **Pre-Assembly Section "Door Glides" (page 8)** and Steps **21 - 23** for full details on fitting door glides and adjustment of doors.

SECURING & SEALING SHED BASE RAILS:

We recommend the following procedure for securing and sealing shed base rails to concrete floor:

SECURE -

Secure shed base rails to concrete floor using dyna-bolts as shown in diagram.

SEAL -

Ensure floor is free of dust and debris and apply silicone on inside of shed, along the edge of the base rail and to the floor.

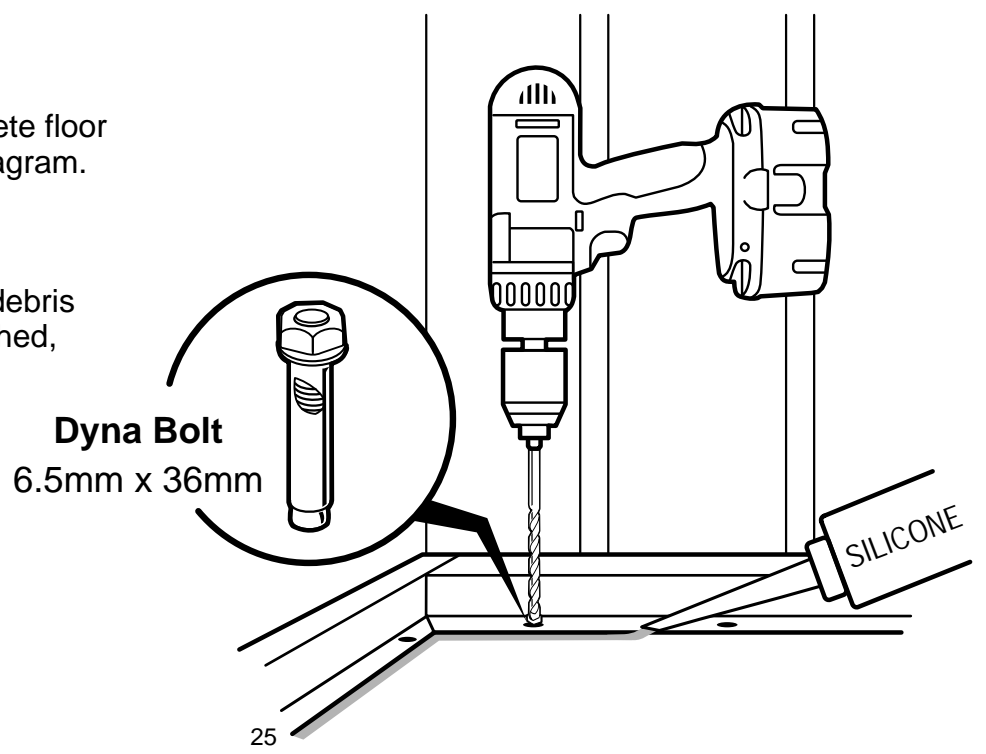

Warranty Clause

10 Year (Limited)

1. You must have a copy of your original purchase receipt if warranty is required.
2. Globel Garden Sheds are built for the purpose of domestic use only and must be installed according to the steps and procedures in the assembly instructions booklet herewith.
3. Installation of shed in ocean locations, heavy industrial or unusually corrosive environments voids the warranty.
4. Warranty does not apply if proven that a third party contaminate contributed to the fault.
5. Warranty is not transferable.
6. Fasteners, door glides and other plastic parts are not covered by the warranty.
7. Missing components must be claimed within 14 days of purchase.
8. For any warranty claim you must contact the original place of purchase.
9. Any expenses incurred by the claimant in conducting their claim will be at the expense of the claimant.
10. Any expenses and/or labour incurred costs by the claimant for the purpose of the replacement and/or fixing any parts to the shed will be at the claimants expense.

Purchase details:

Date of Purchase

Model / Product Code

Place of Purchase

Receipt Number

FOR YOUR RECORDS
PLEASE STAPLE ORIGINAL
PURCHASE RECEIPT HERE

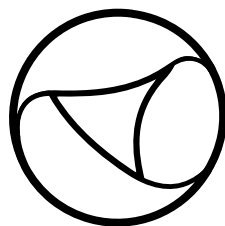

GLOBEL[®]

www.globelindustries.com