



Eden

Greenhouses

Blockley

(8'5" WIDE)

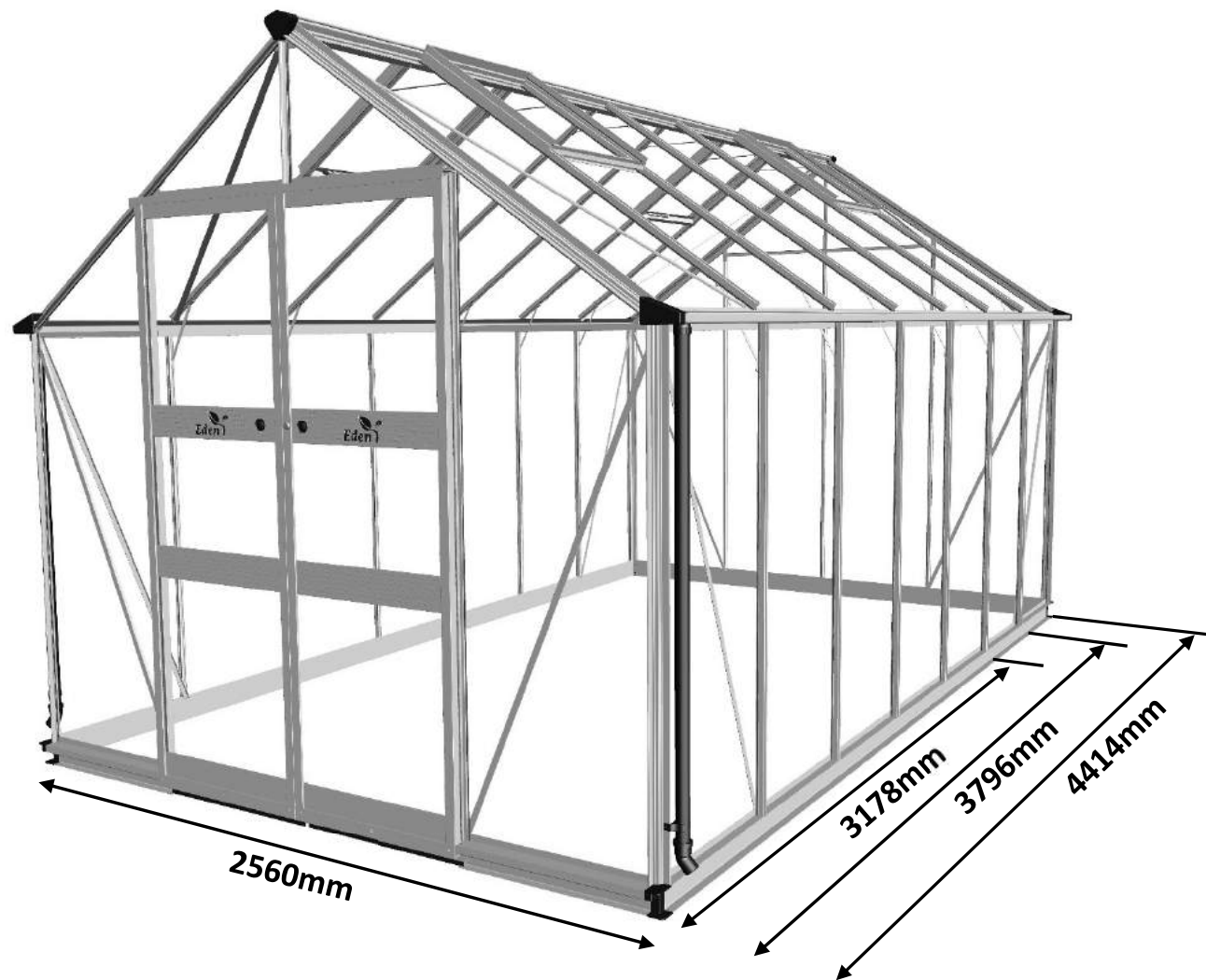

www.edengreenhouses.com

Customer Helpline: +44 (0)1242 676625

Mon – Fri 9:00am – 5:00pm

mail@eden-greenhouses.com

RN00300819

EM 1.01

Dear Customer,

Congratulations on purchasing your new Eden greenhouse.

Before you start, please read this instruction booklet carefully. The components for your greenhouse are in numbered bundles corresponding to the sections in this booklet. There may be more than 1 bundle per section. Build one section at a time. **IF YOUR GREENHOUSE IS POWDERCOATED, TAKE CARE WHEN OPENING PACKAGES NOT TO SCRATCH PAINTWORK.**

NOTE: These instructions are for more than one length of greenhouse.

Precautions

- Please allow plenty of time for construction.
- Assembly must be carried out in dry and calm weather.
- A minimum of two people are required to construct the greenhouse.
- We recommend using the tools supplied to tighten bolts. Electric drills can lead to cross threading issues and bolts shearing.
- Place step ladder on level ground.
- Extreme care should be taken when handling glass: always use appropriate gloves and goggles while glazing. Greenhouse glass can have sharp edges, especially if there are any breakages.
- Do not, under any circumstances, climb step ladders whilst carrying glass.
- If there are any breakages, pick up broken glass immediately taking care to keep children and pets away until completely cleared.
- We also recommend using protective gloves and goggles when fitting spring wire clips due to the extreme tension. There is a helpful video clip under the "Help and Advice" tab on our website www.edengreenhouses.com.

Tools supplied

1 x Box spanner

1 x 10mm flat spanner

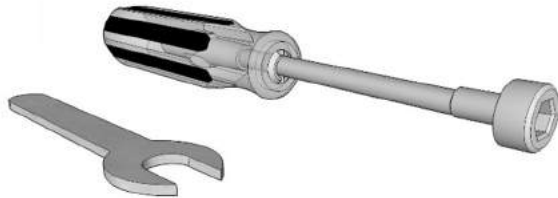

Tools and safety equipment

Recommended

- Step ladder
- Drill (anchoring only)
- Spirit level
- Tape measure
- Utility knife
- Scissors
- 7mm socket
- Screwdrivers – flat, PZ2
- Safety gloves
- Safety goggles



Selecting a site

The location of your greenhouse is very important. The structure needs to get as much sunlight as much as possible but should not be exposed to high winds. Try to avoid locating your greenhouse under trees as this will cast shade, which encourages a build-up of algae and falling branches or leaves could cause damage to the structure or block guttering. Sap from trees can make the glazing sticky and dirty so it lets in less light. Creating a level and square base is the most important step in successfully assembling your greenhouse: selecting a site that is already quite level will make the assembly process much easier.

Site preparation

Please refer to the front cover of this booklet for the **OVERALL dimensions** of your greenhouse. If you are siting the greenhouse on earth, you will need to dig 6 holes for the ground anchors, as shown in **SECTION 0, FOUNDATION, approx. 300mm deep x 200mm in diameter**. You will need post concrete for the ground anchors and, depending on your soil type, you may need plastic pipes to stop the ground crumbling in on itself. If you are siting the greenhouse on slabs/concrete, cut the ground anchors off with a hack-saw so that they are level with the base as shown in **SECTION 8 LOCATING, pic 2**. To secure the base down pour concrete into pre dug holes with ground anchors situated in place. For slab/concrete foundation, using the L-shaped brackets provided, drill into the concrete/slabs using a 7mm masonry drill bit and secure using 8mm plugs and screws as shown in **SECTION 10 FINISHING**.

Base

The integral base must be 100% level and square, the latter can be done by checking the 2 diagonals are equal. If it is not square the glazing will not fit.

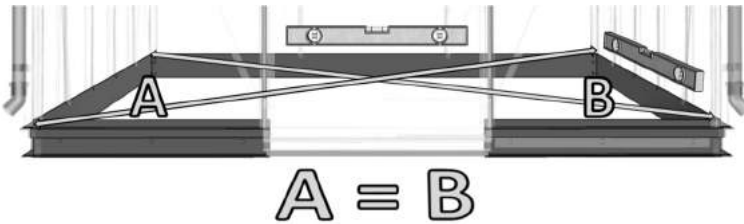

Construction

COMPONENTS LIST
SECTION 0 FOUNDATION
SECTION 1 REAR GABLE
SECTION 2 FRONT GABLE
SECTION 3 SIDES
SECTION 4 ASSEMBLE
SECTION 5 ROOF
SECTION 6 WINDOWS
SECTION 7 DOOR
SECTION 8 LOCATING
SECTION 9 GLAZING
SECTION 10 FINISHING

For each section, lay the profiles out on the ground in the same way as pictured in the main diagram. Assemble in the order of the pictures.

M6 x 10 bolts/nuts (parts 50 and 51) are not listed on individual parts lists as they are used in each section.

The following symbols show whether an illustration is viewed from inside or outside the greenhouse:

Viewed from the inside
(White background)

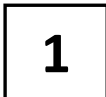

Viewed from the outside
(Black background)



Take note of where you will need to slide **extra bolts** into the channels for fixing horizontal bars, bracing or roof vent sills as per example picture to the right.

Fasten the profiles together by sliding the square headed bolts into the channel of the profile and attach to the hole in the corresponding bar. Do not tighten the nuts completely until the completed frame is square. **NOTE THAT ALL CONNECTING PROFILES MUST BE FLUSH AND TIGHT TOGETHER TO ENSURE THAT LEAKING IS KEPT TO A MINIMUM.**



The door has a zero threshold™. Component 96 at the base of the door on the front gable (**SECTION 2 FRONT GABLE**) is used as a brace to gauge the distance between the two components 18 and to make construction easier. This will then be removed in **SECTION 10 FINISHING**.

Glazing

Glazing must be completed in one operation. Fit the rubber glazing gasket to all the profiles as shown in **SECTION 8, LOCATING** before fitting the glass. Note there are 3 different plans for glazing: horticultural glass, toughened glass or polycarbonate. Glaze the roof first, then sides and gable ends. Glaze roof vents before sliding in from **THE END** of the ridge bar as shown in **SECTION 10 FINISHING**. Glaze the door before hanging as shown in **SECTION 7 DOOR**.

Finishing Touches





Fit all plastic parts, i.e. Ridge Cap, Gutter End Caps and Integral Base Corner Caps by pushing into place as in **SECTION 10, FINISHING**.



















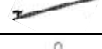

Note: Fit Integral Base Corner Caps before securing down the greenhouse.

Maintenance





















- The door sliders and lock will need to be lubricated approximately every 6 months with an **OUTDOOR** lubricant to ensure smooth operation.
- The gutters will need to be regularly cleared of leaves and debris to ensure efficient drainage.
- Replace all broken panes of glass immediately, failure to do so may cause structural failure.
- Remove snow loads from the roof.

Components List

	POS	Length mm	8x10	8x12	8x14	No.
	1	1492	16	20	24	RP228501492
	2	3118	2			RP2078413118
	2	3736		2		RP2078413736
	2	4354			2	RP2078414354
	3	3118	2			RP137843118
	3	3736		2		RP137843736
	3	4354			2	RP137844354
	4	1609	8	8	8	RP2079111609
	5	1492	8	8	8	RP309331492
	6	2500	1	1	1	RP137842500
	7	1921	2	2	2	RP228501921
	8	1575	4	4	4	RP2079111575
	9	-	6	6	6	RN00310236
	10	2486	1	1	1	RP243252486
	15	-	2	2	2	RN00310232
	16	1919	2	2	2	RP233651919
	18	646	2	2	2	RP137850646
	19	632	2	2	2	RP2079110632
	20	1270	1	1	1	RP2079091270

	22	3118	1			RP2078403118
	22	3736		1		RP2078403736
	22	4354			1	RP2078404354
	24	636	4	4	4	RP309300636
	25	606	8	8	8	RP1070400606-25
	26	610	4	4	4	RP088600610-26
	27	638	4	4	4	RP046940638-27
	28	1900	3	3	3	RP158361900
	29	610	2	2	2	RP288960610-29
	30LH	610	1	1	1	RP2081140610-LH
	30RH	610	1	1	1	RP2081140610-RH
	31	620	2	2	2	RP309340620
	32	610	2	2	2	RP2081140610
	39	2353	1	1	1	RP22852353
	40	300	12	15	18	RP235570300
	42	64,000	2	2	2	RN00300413
	43	-	150	150	150	N00300210
	44	-	450	450	450	N00300205
	45	4,000	1	1	1	RN00300418
	48	-	2	2	2	RN00300227BK
	50	-	300	300	300	N00300605

	51	-	300	300	300	N00300655
	52	-	2	2	2	RN00310035
	53	-	2	2	2	RN00310453
	54	-	2	2	2	RN00310454
	55	-	1	1	1	RN00310415
	55	-	1	1	1	RN00310416
	58	-	20	24	28	RN00310458
	62	422	1	1	1	RP228510422
	63	414	1	1	1	RP244090414
	64	305	6	8	8	RP102640305
	65	1900	1	1	1	RP209171900
	71	-	4	4	4	RN00300301
	74	-	2	2	2	RN00310450
	78	1250	1	1	1	RP2079111250
	90	-	2	2	2	RN00310413
	95	620	2	2	2	RP2079100620
	96	1250	1	1	1	RP2079111250
	97	610	2	2	2	RP2079120610
	100	-	6	6	6	00402
	101	-	4	4	4	N00300422

	102	-	26	26	26	N00300602
	103	-	26	26	26	N00300603
	104	-	2	2	2	N00300604
	105	-	2	2	2	PT200
	106	-	2	2	2	PT204
	107	-	2	2	2	RN00310418
	109	610	2	2	2	RN00310420
	110	-	2	2	2	N00300606
	111	-	1	1	1	RN00310422
	112	170	2	2	2	RN00310426
	113	1400	2	2	2	RN00310428
	114	600	4	4	4	RN00310437
	115	-	2	2	2	RN00310462
	116	-	1	1	1	RN00310463
	117	-	1	1	1	RN00310464
	118		26	26	26	01645
	119		4	4	4	RN00310439
	120		300	300	300	00682BK
	121	-	2	2	2	PT201
	H	610	6	6	6	12467

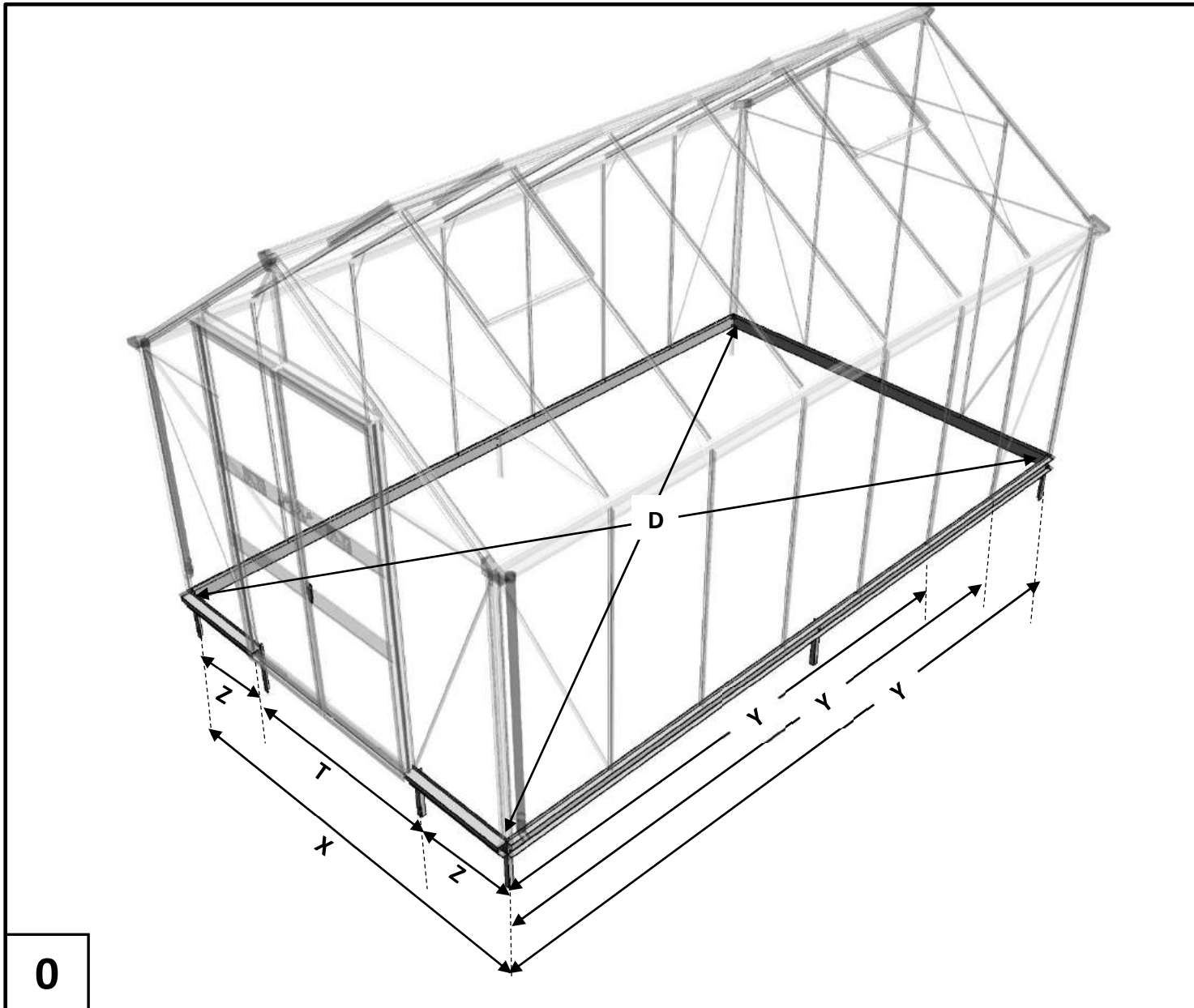

	810	812	814
X	2500mm	2500mm	2500mm
Y	3118mm	3736mm	4354mm
Z	646mm	646mm	646mm
T	1208mm	1208mm	1208mm
D	3996mm	4495mm	5021mm



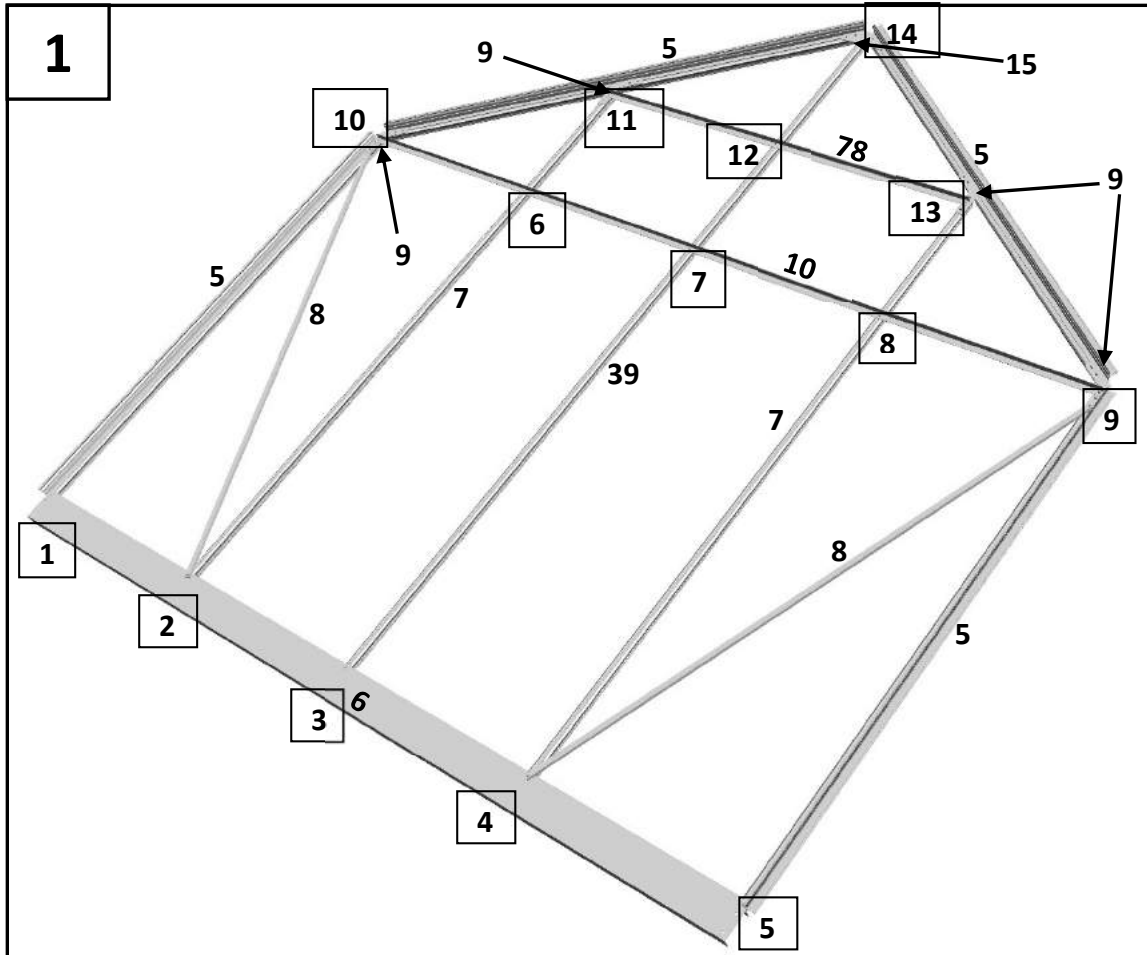

1	#	mm	810	812	814	PART NO.
	6	2500	1	1	1	RP137842500
	5	1492	4	4	4	RP309331492
	7	1921	2	2	2	RP228501921
	8	1575	2	2	2	RP2079111575
	9	-	4	4	4	RN00310237
	10	2486	1	1	1	RP243252486
	15	-	1	1	1	RN00310232
	78	1250	1	1	1	RP2079111250
	39	2353	1	1	1	RP228502353

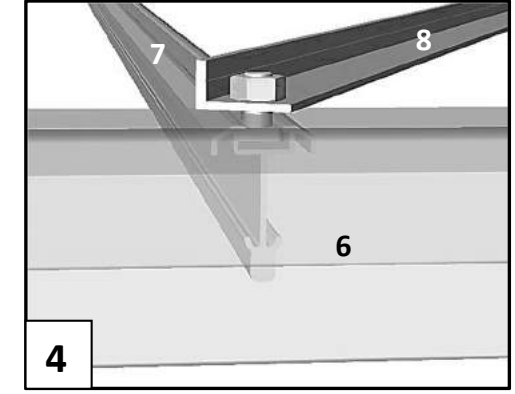
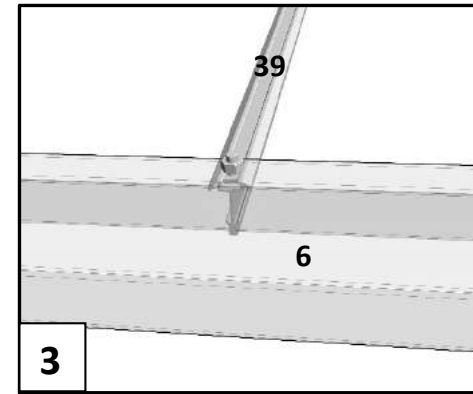
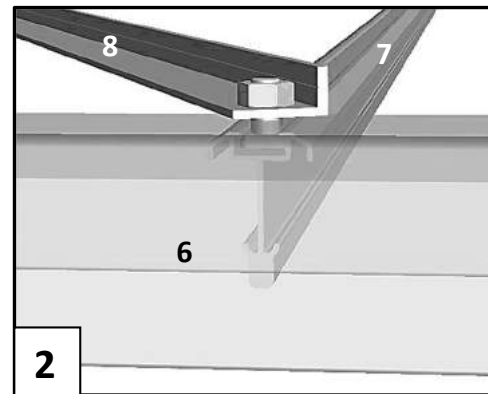
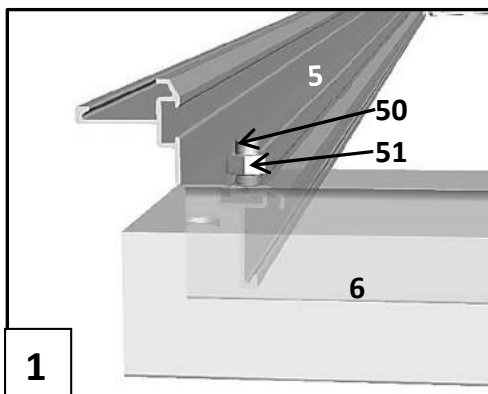

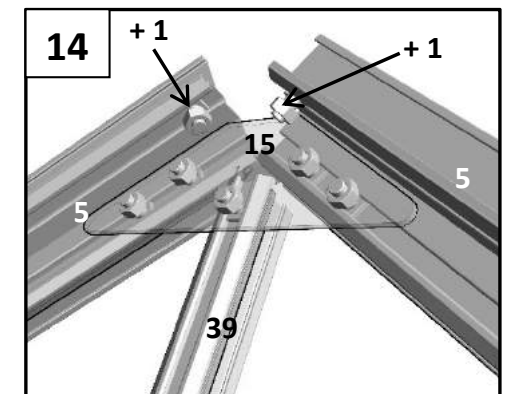
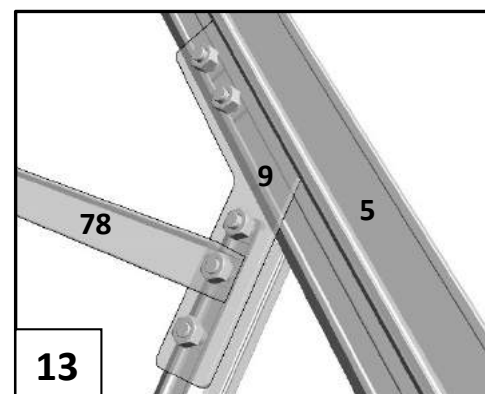
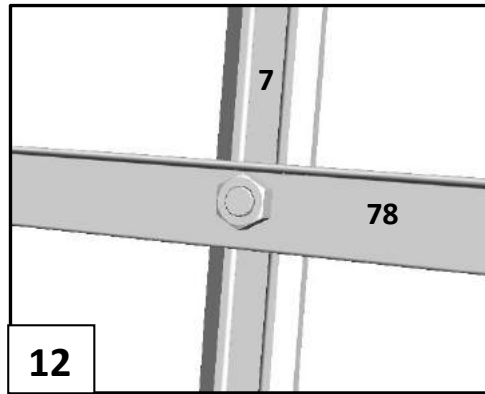
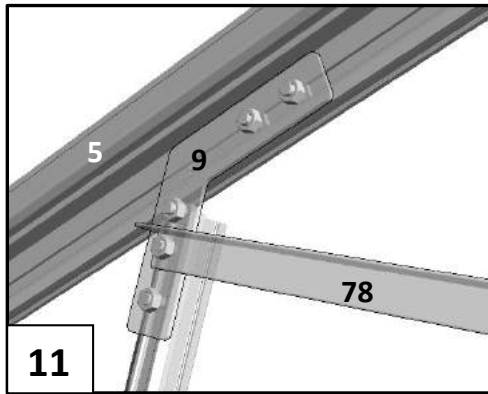
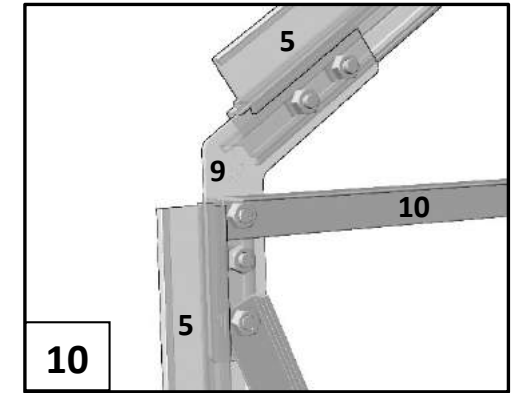
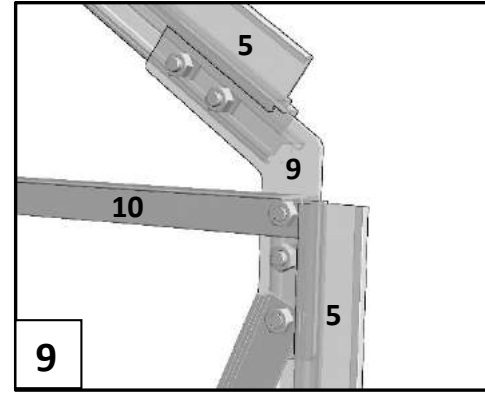
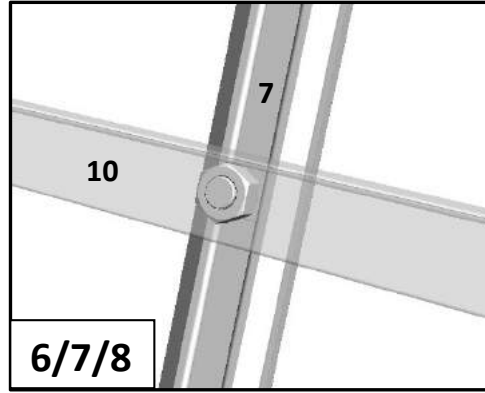
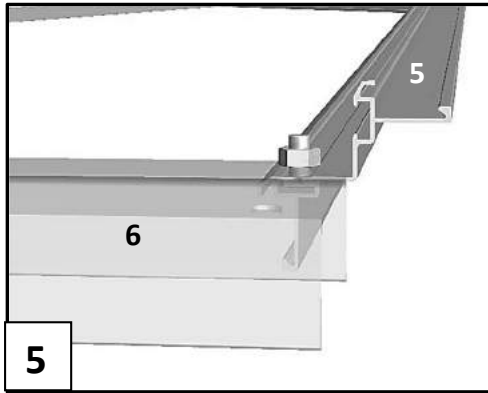

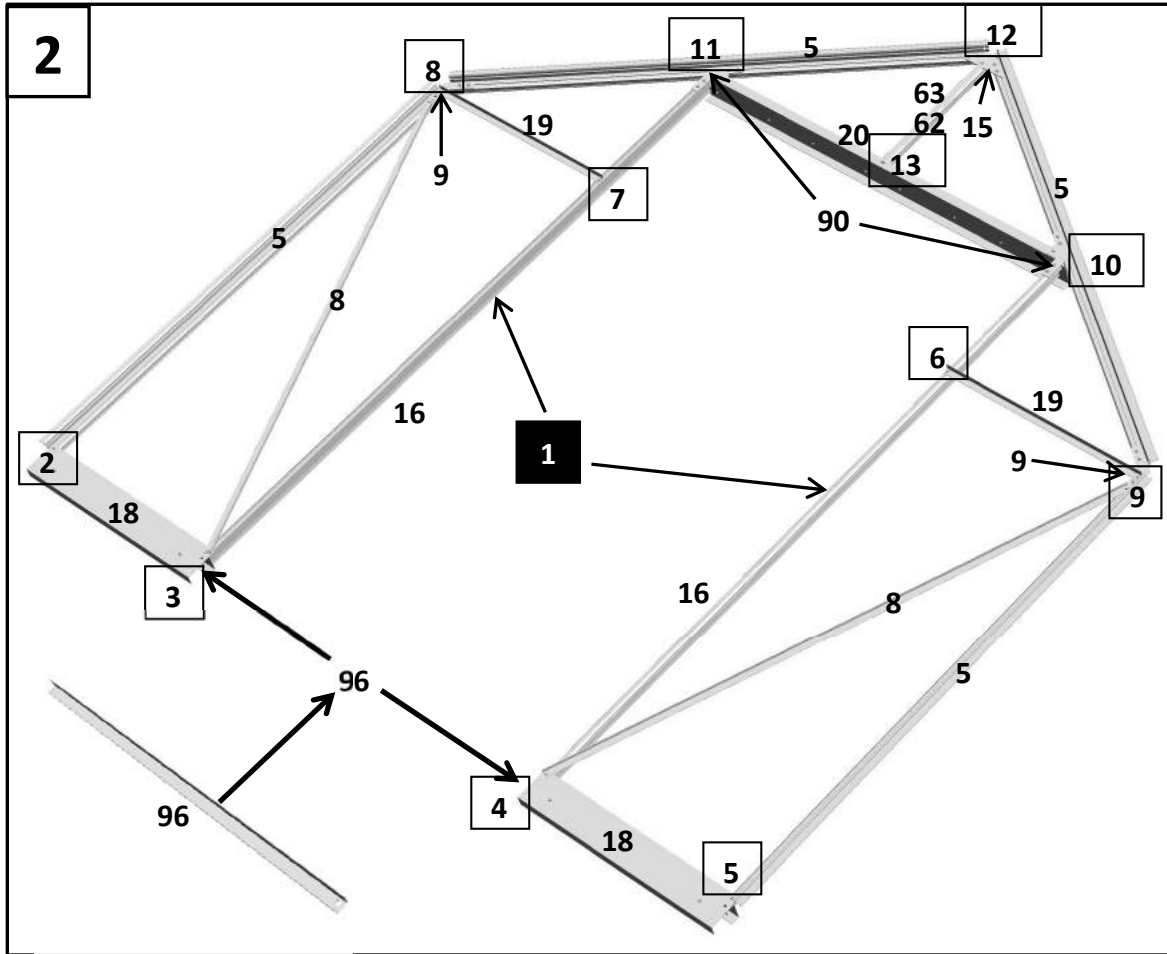

2	#	mm	810	812	814	ITEM NO.
	45	4000	1	1	1	RN00300418
	16	1919	2	2	2	RP233651919
	18	646	2	2	2	RP137850646
	5	1492	4	4	4	RP309331492
	8	1575	2	2	2	RP2079111575
	9	-	2	2	2	RN00310237
	90	-	2	2	2	RN00310413
	20	1270	1	1	1	RP2079091270
	19	632	2	2	2	RP2079110632
	15	-	1	1	1	RN00310232
	62	422	1	1	1	RP228510422
	63	414	1	1	1	RP244090414
	96	1250	1	1	1	RP2079111250

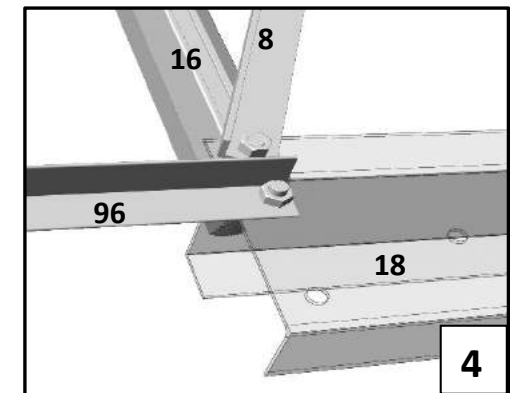
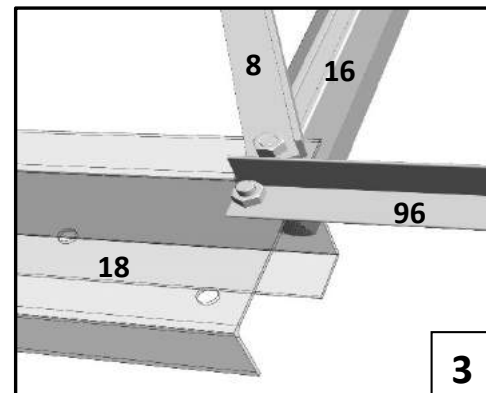
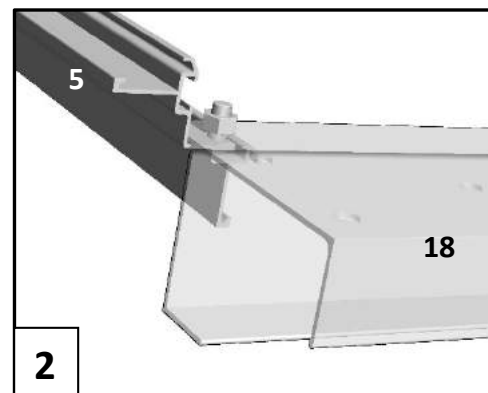
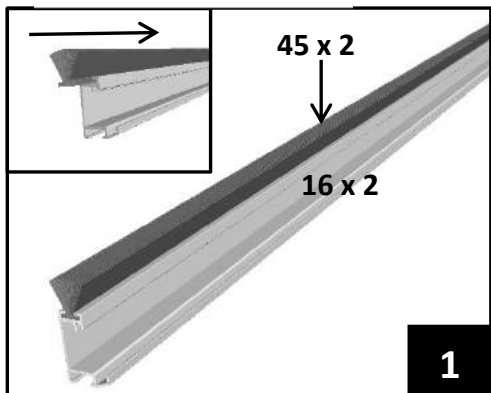

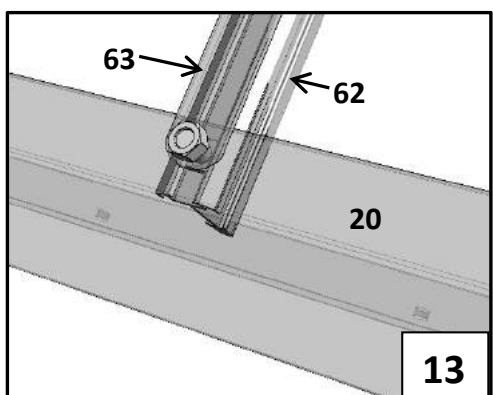
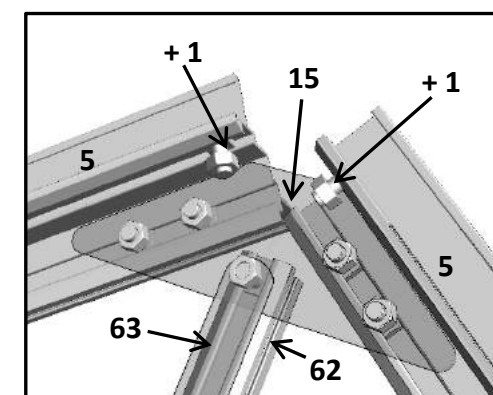
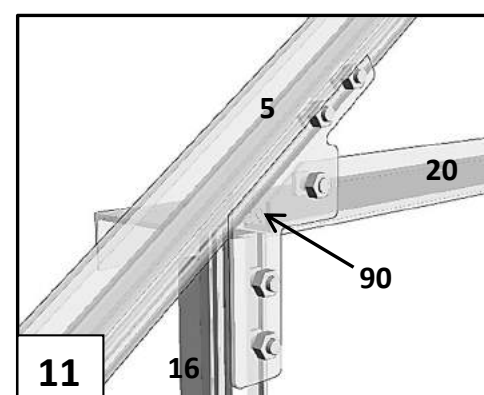
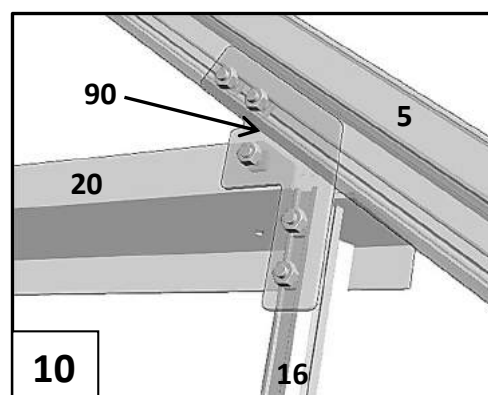
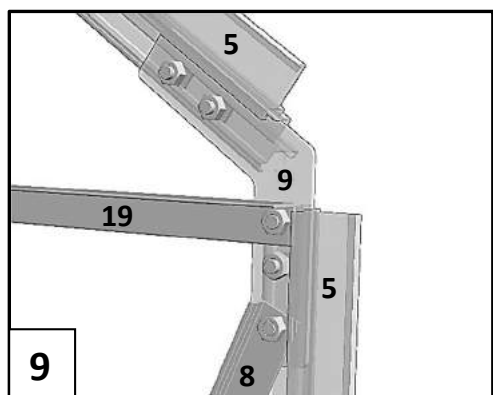
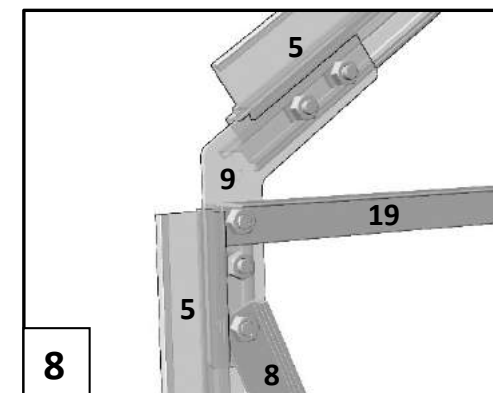
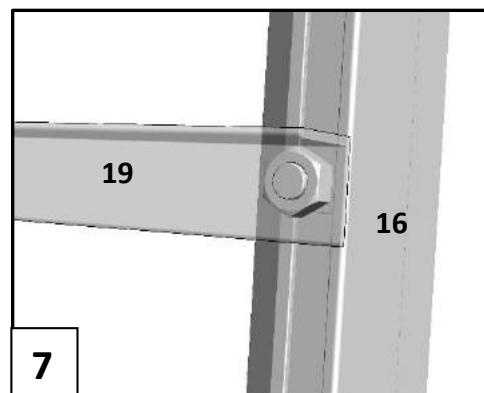
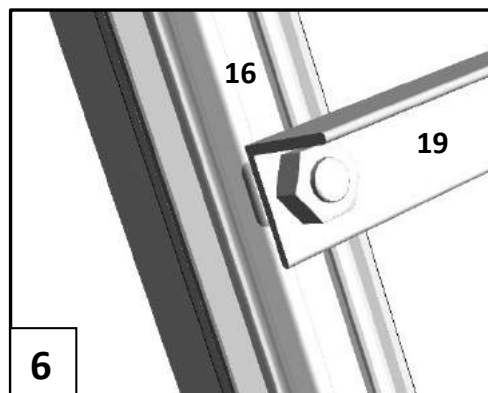
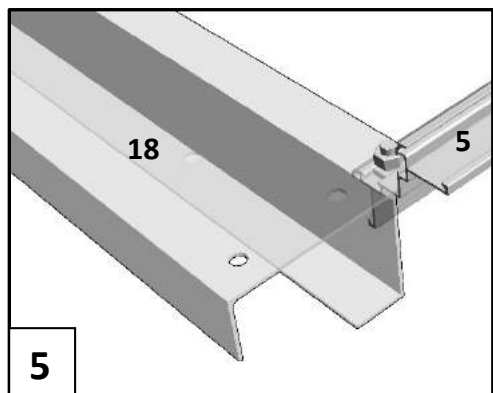

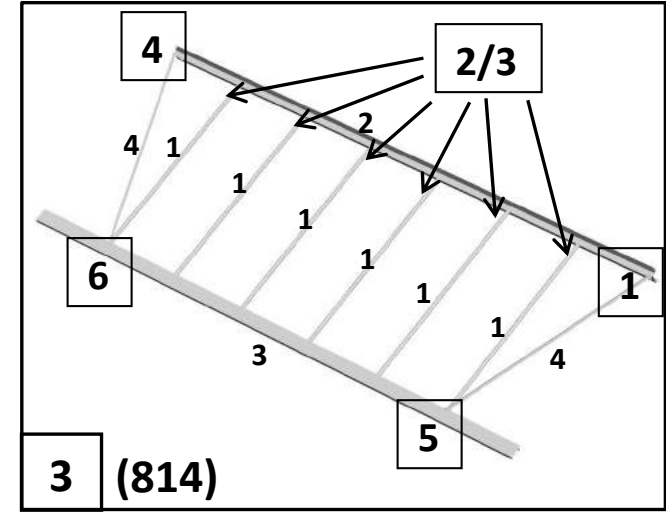
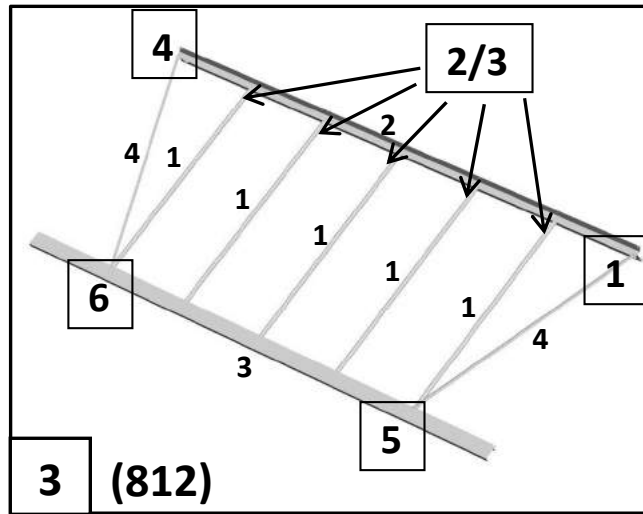
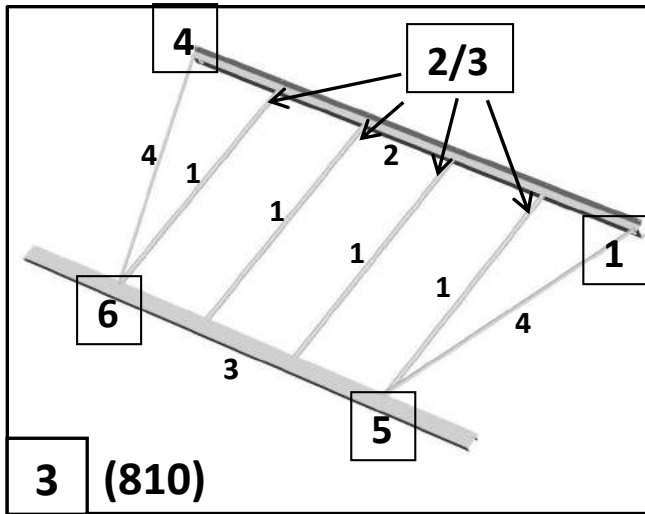

3	#	mm	810	812	814	ITEM NO.
	1	1492	8	10	12	RP228501492
	2	3118	2			RP2078413118
	2	3736		2		RP2078413736
	2	4354			2	RP2078414354
	3	3118	2			RP1378413118
	3	3736		2		RP1378413736
	3	4354			2	RP1378414354
	4	1609	4	4	4	RP2079111609

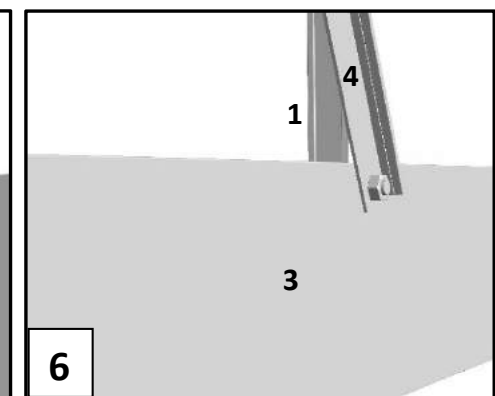
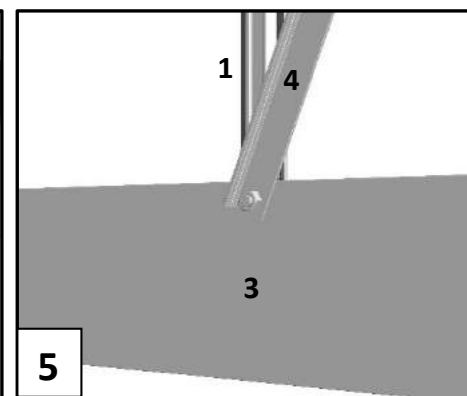
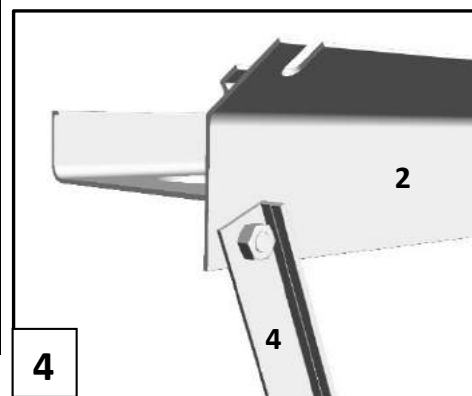
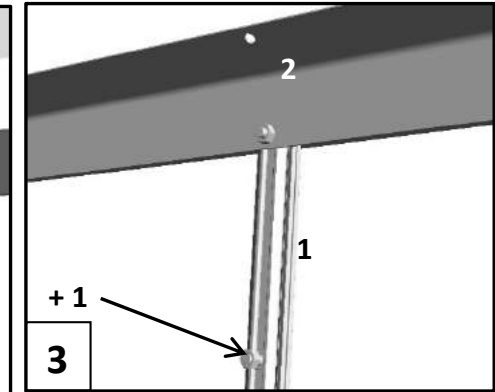
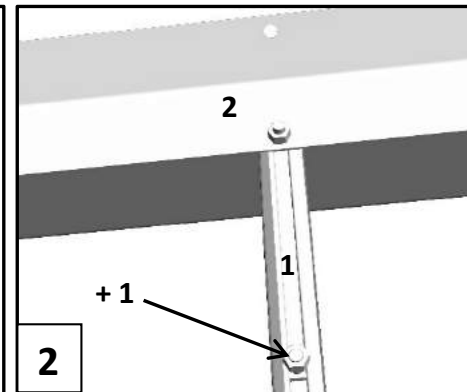
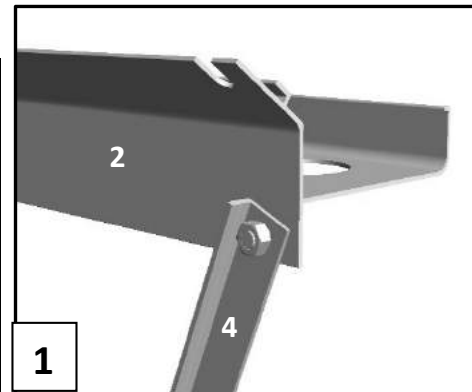

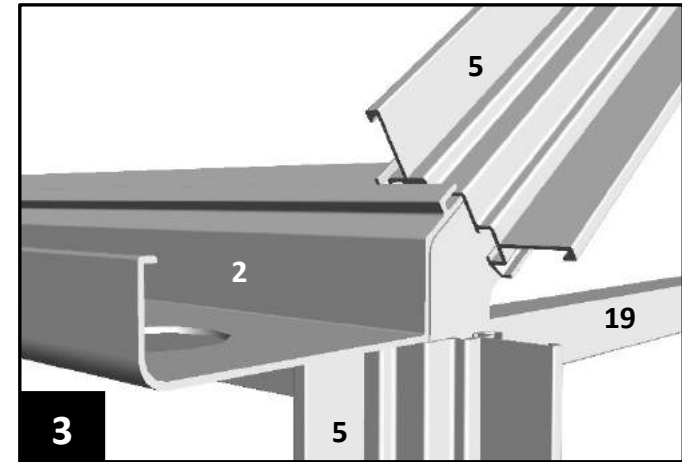
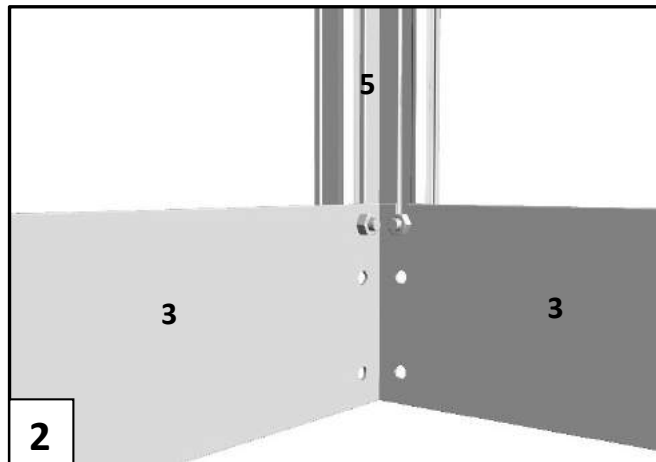
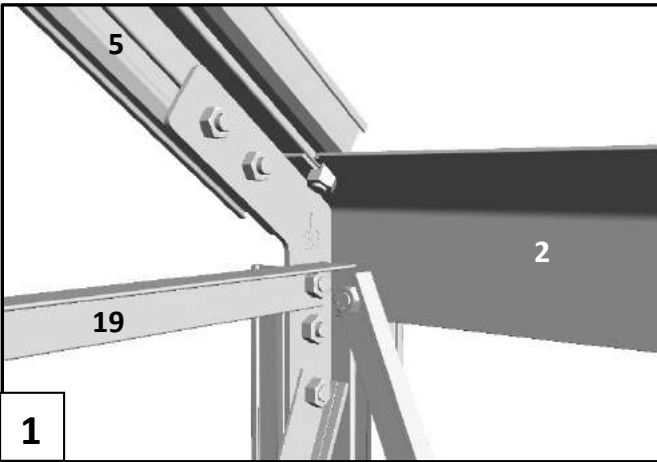
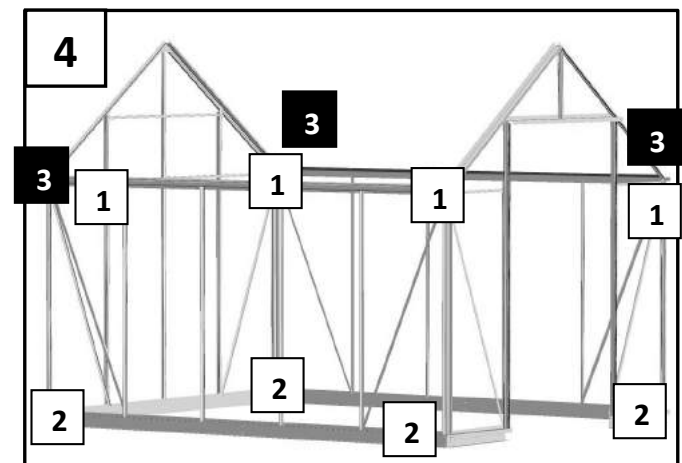
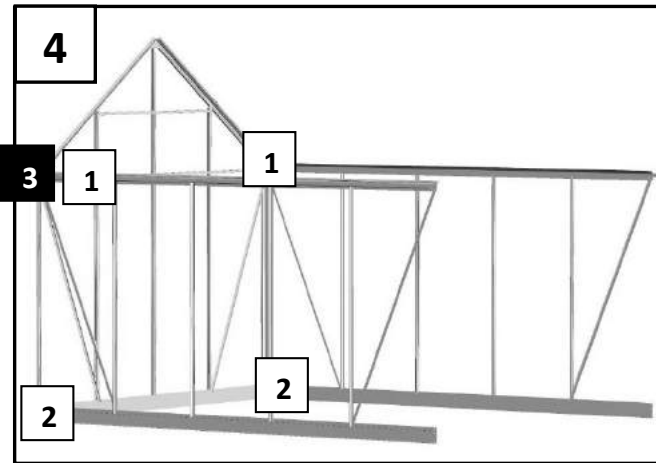
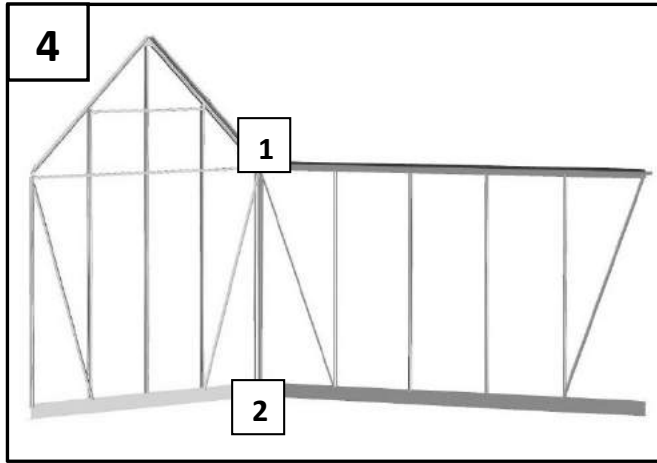

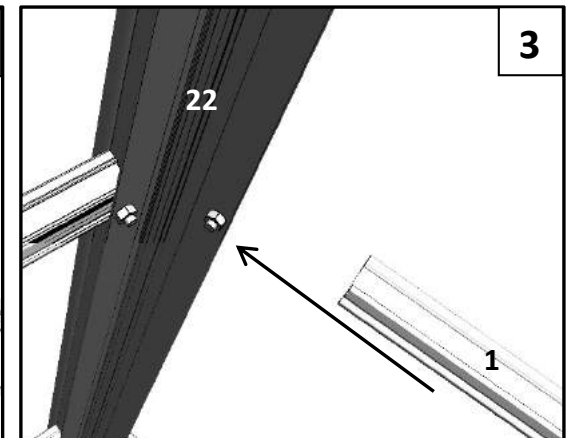
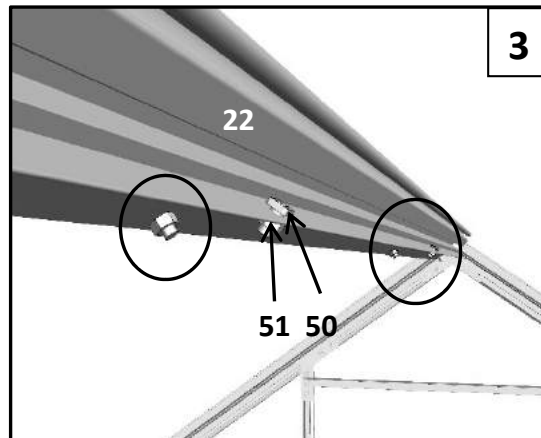
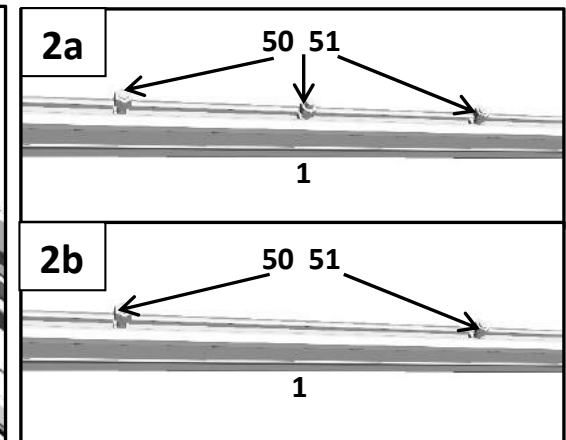
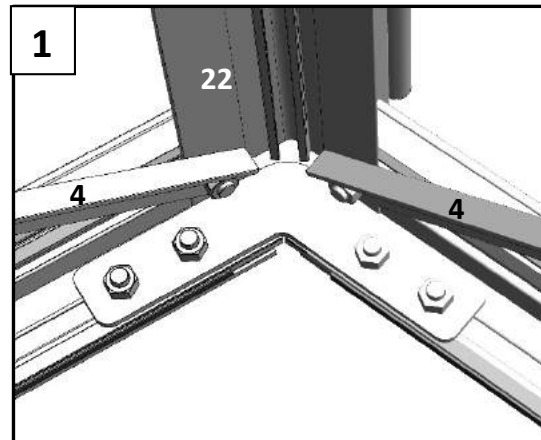
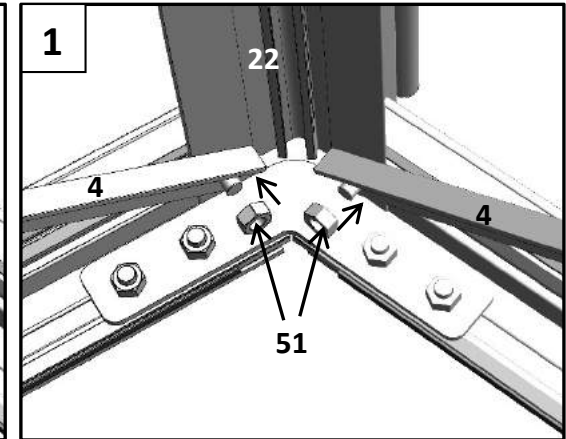
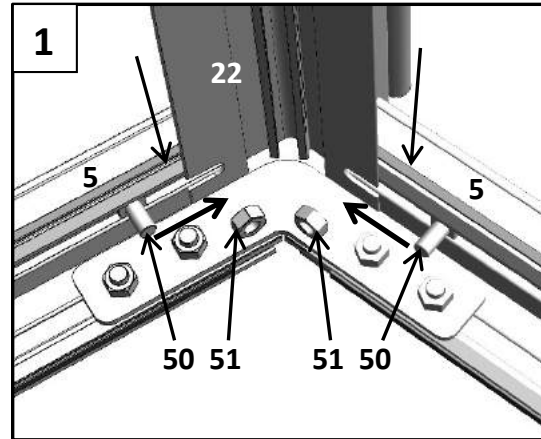
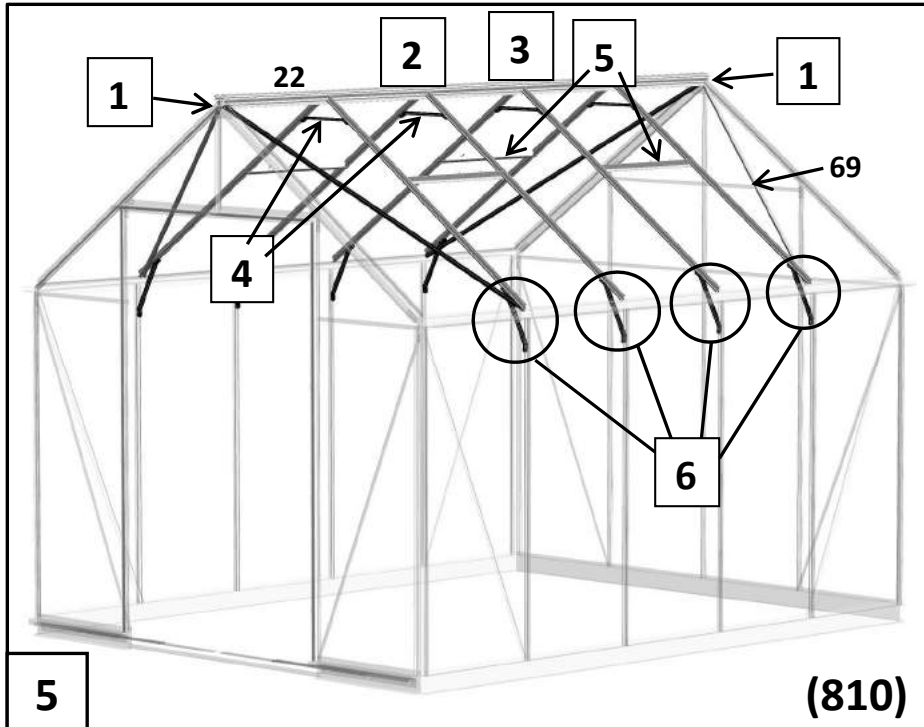

5	#	mm	810	812	814	ITEM NO.
	22	3118	1			RP20784013118
	22	3736		1		RP2078403736
	22	4354			1	RP2078404354
	1	1492	8	10	12	RP228501492
	4	1609	4	4	4	RP2079111609
	27	638	4	4	4	RP046940638-27
	40	300	12	15	18	RP235570300

1	2a	2b
810	x 8	
812	x 8	x 2
814	x 8	x 4

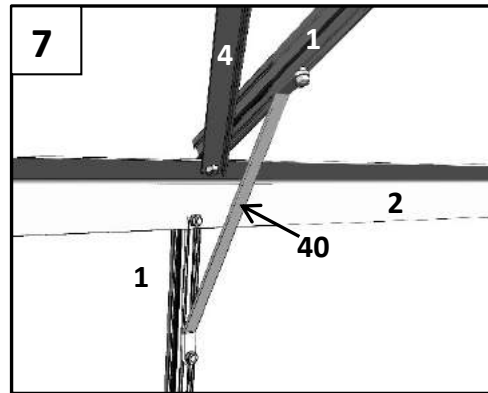
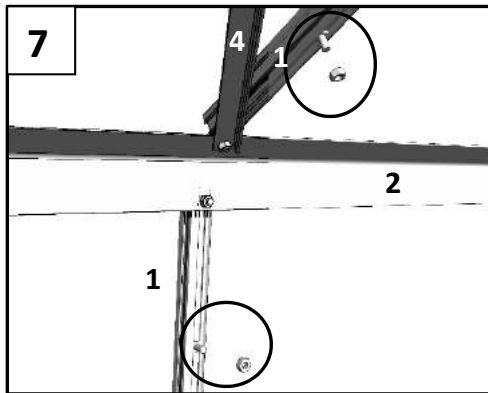
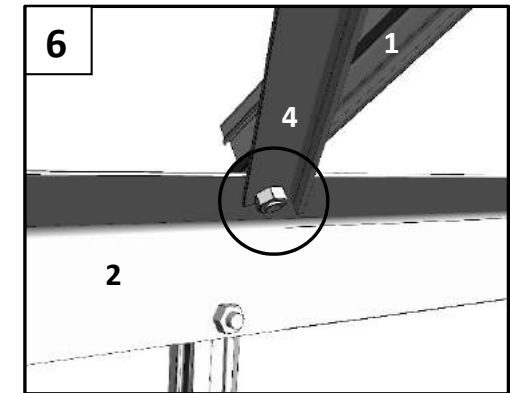
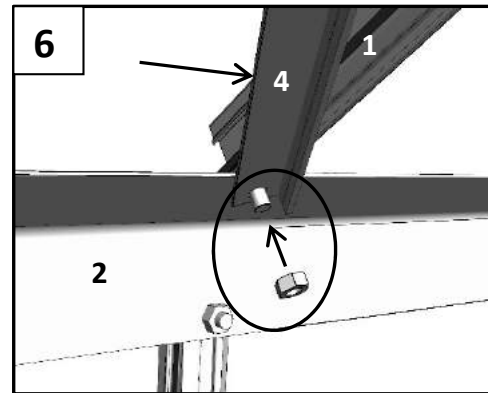
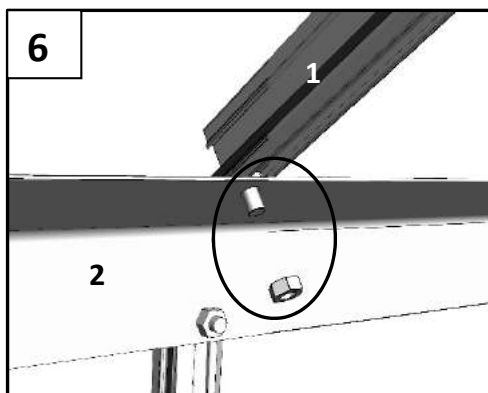
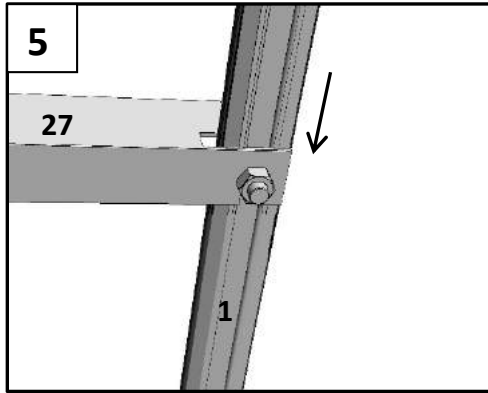
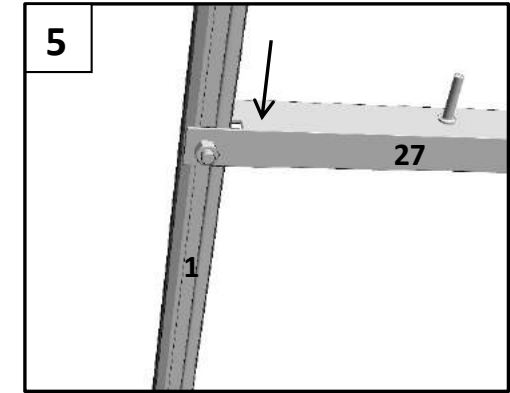
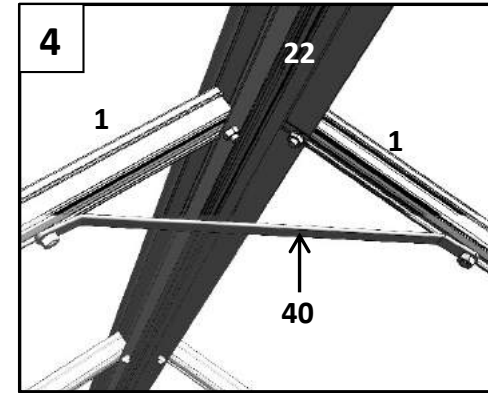
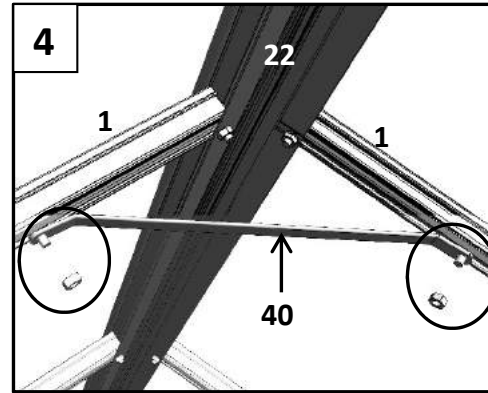
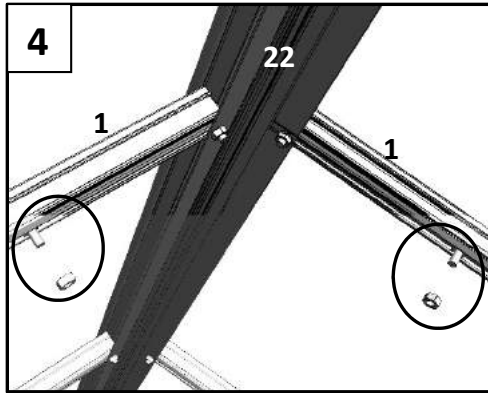

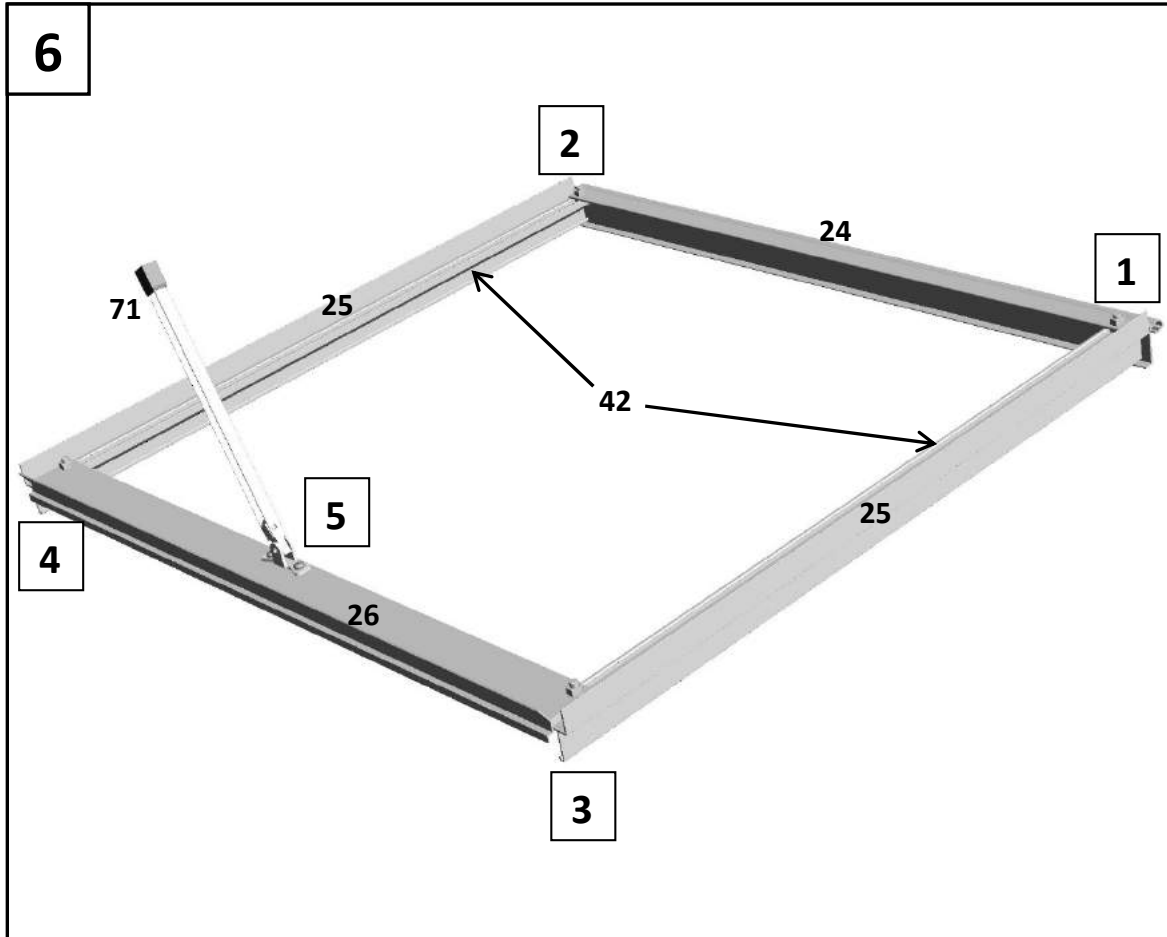

6	#	mm	810	812	814	ITEM NO.
	42	64000	1	1	1	RN00300413
	25	606	8	8	8	RP1070400606-25
	24	636	4	4	4	RP309300636
	26	610	4	4	4	RP088600610-26
	71	-	8	8	8	RN00300301
	71	-	4	4	4	RN00300301

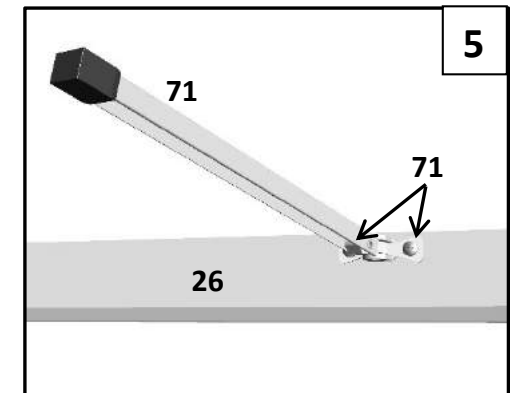
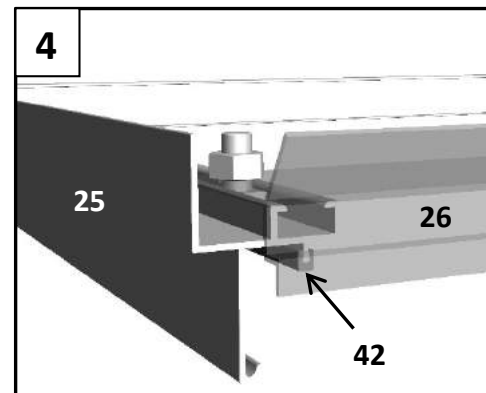
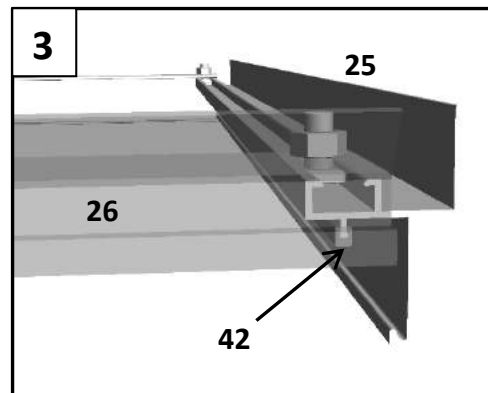
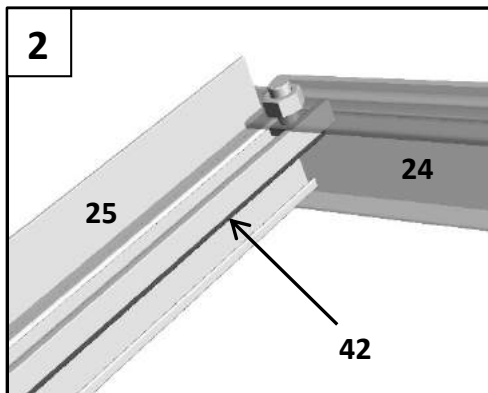
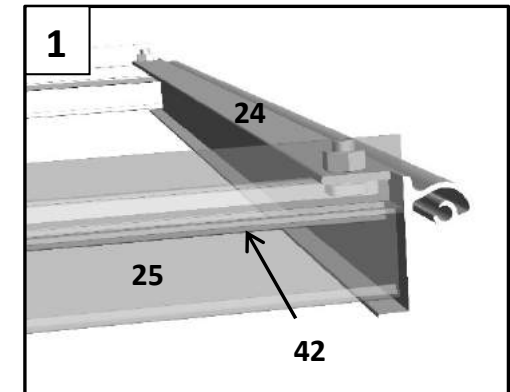

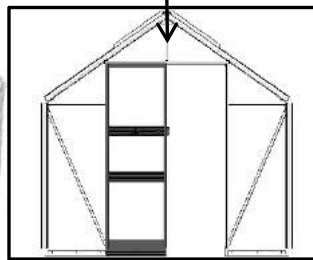
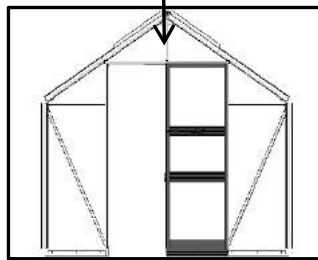
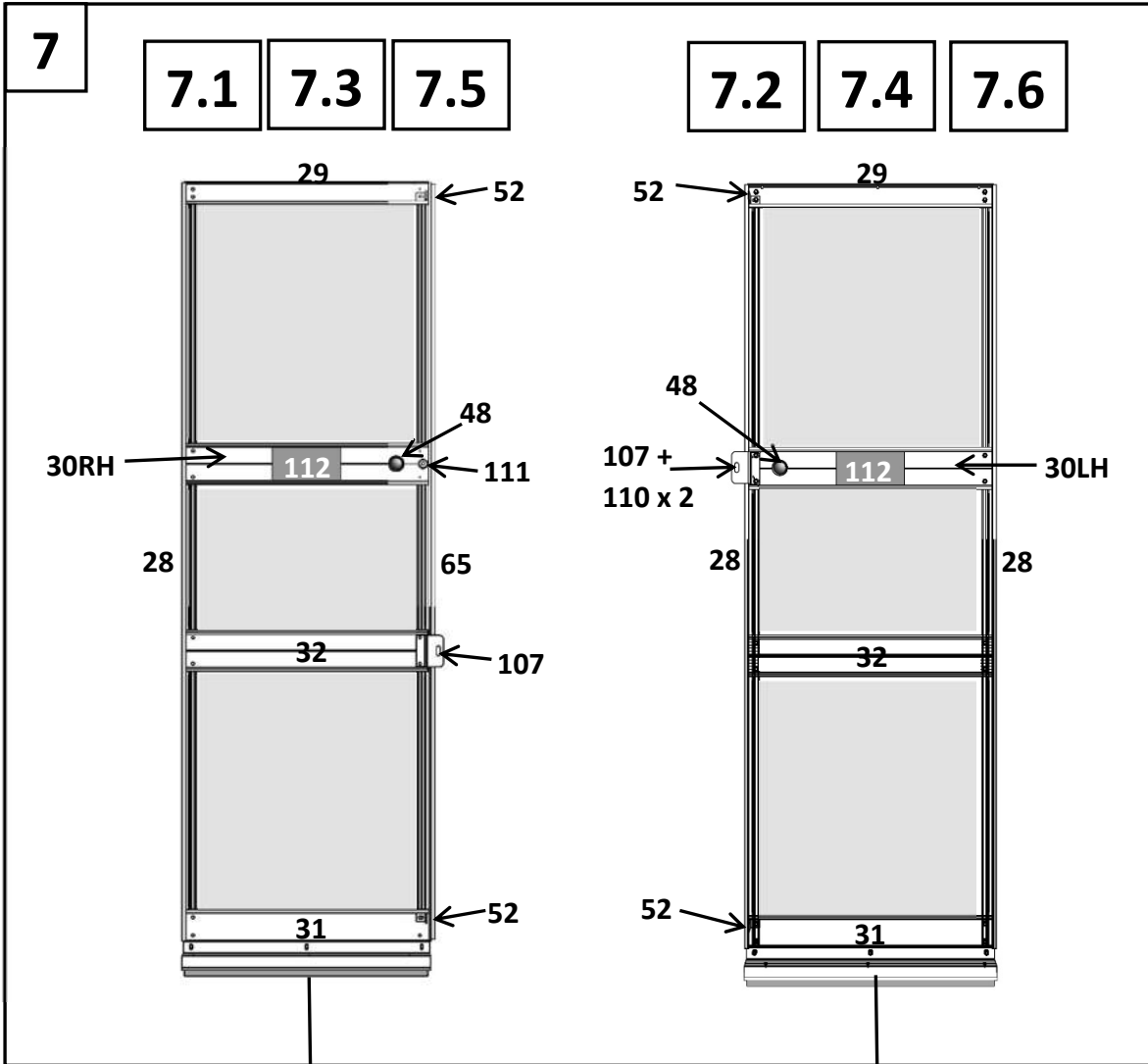

7	#	mm	810	812	814	ITEM NO.
	42	64000	2	2	2	RN00300413
	65	1900	1	1	1	RP209171900
	28	1900	3	3	3	RP158361900
	29	610	2	2	2	RP288960610-29
	30RH 30LH	610	1 1	1 1	1 1	RP2081140610-RH RP2081140610-LH
	112	170	2	2	2	RN00310426
	32	610	2	2	2	RP2081140610
	31	620	2	2	2	RP309340620
	52	-	4	4	4	RN00310035
	107	-	2	2	2	RN00310421
	110	-	2	2	2	N00300606
	111	-	1	1	1	RN00310422
	111	-	1	1	1	RN00310422
	48	-	2	2	2	RN00300227BK

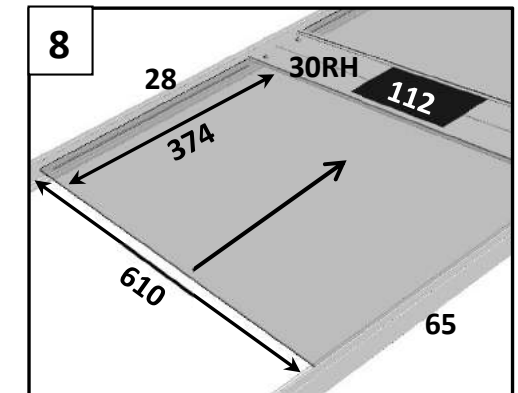
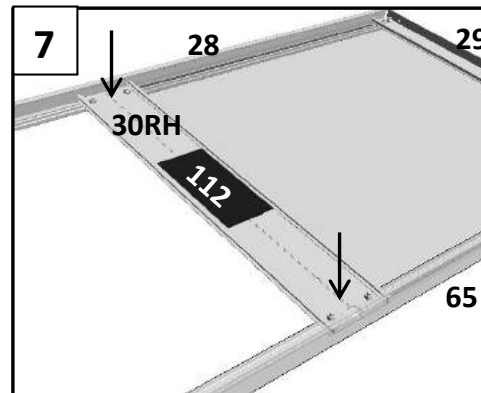
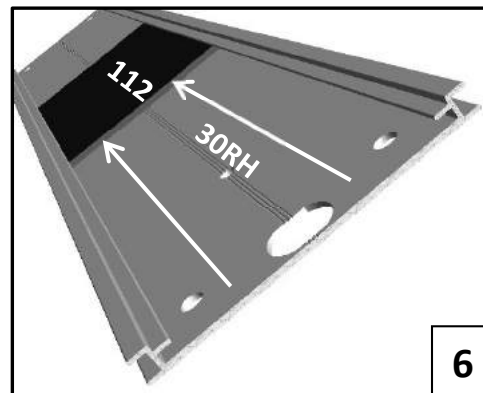
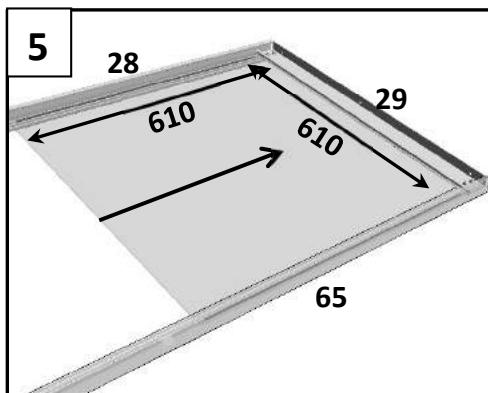
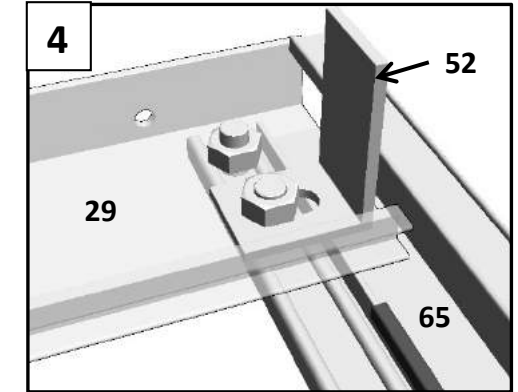
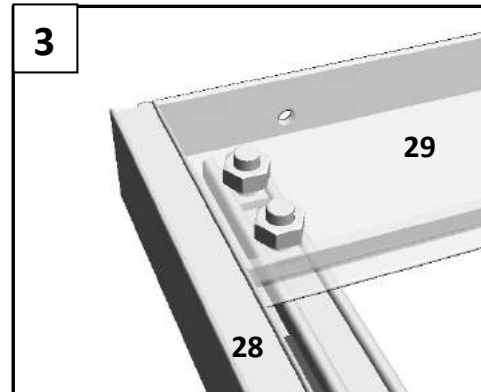
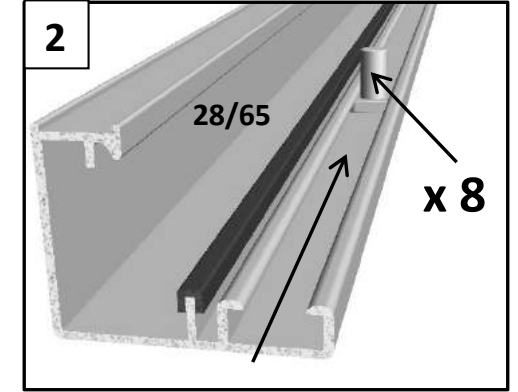
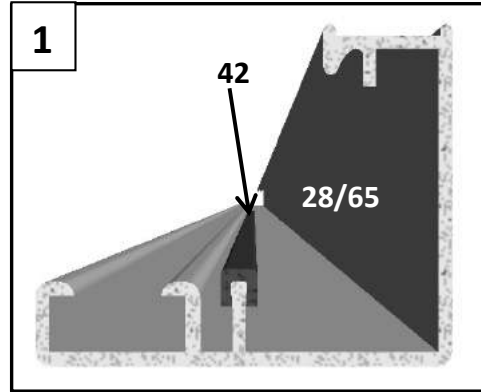
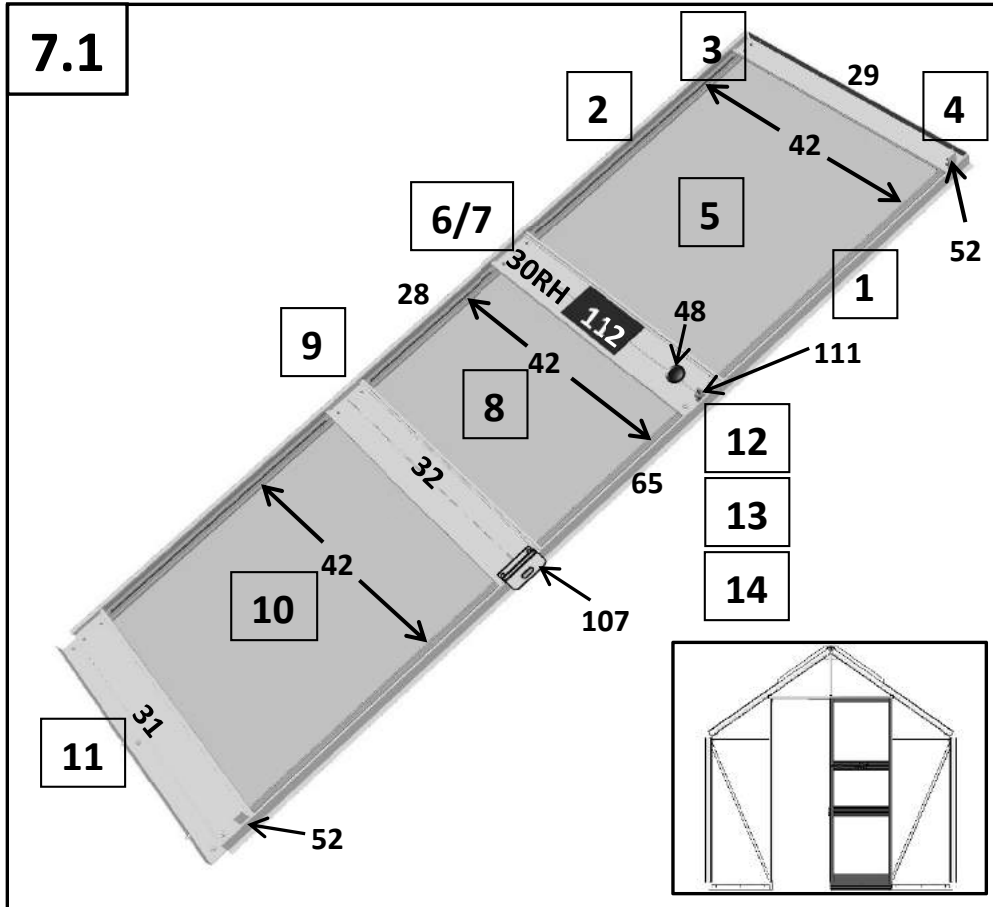

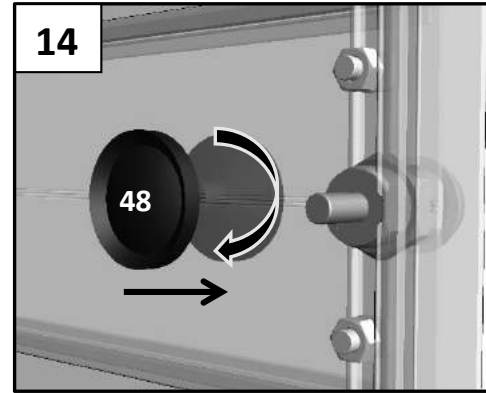
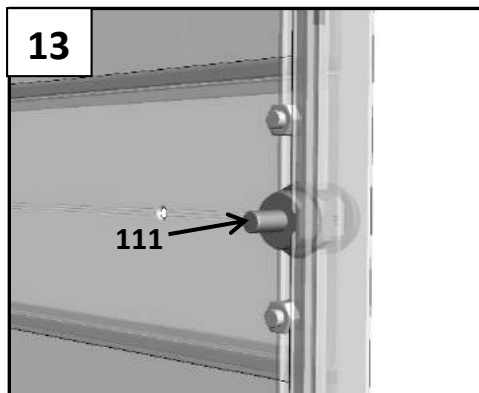
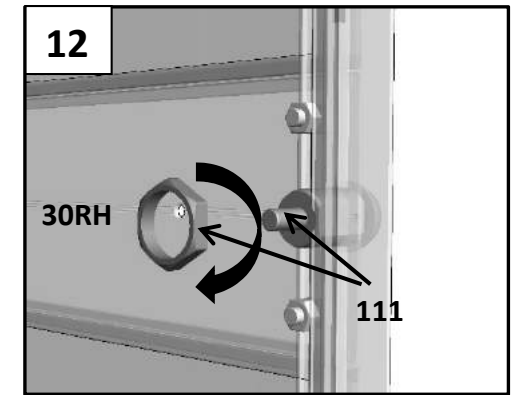
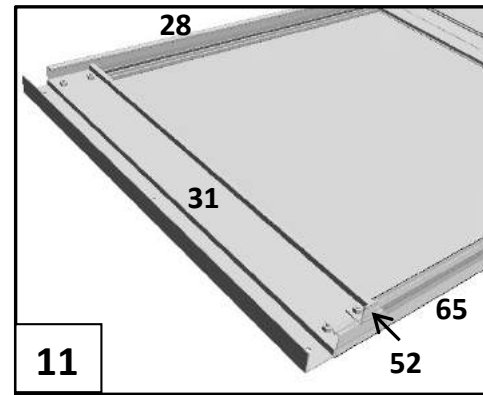
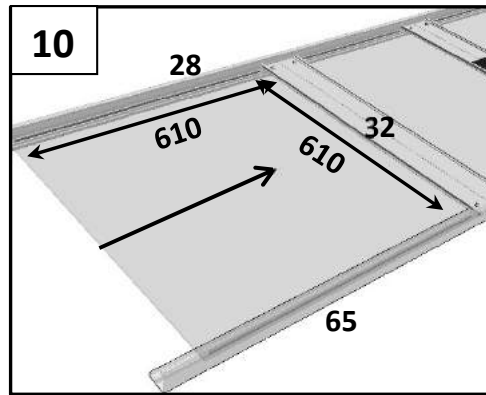
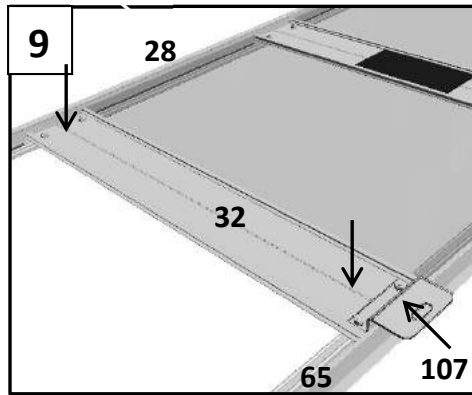

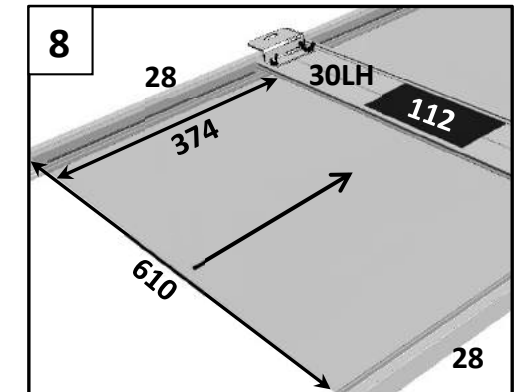
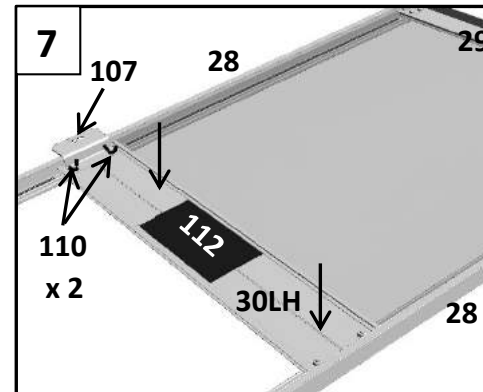
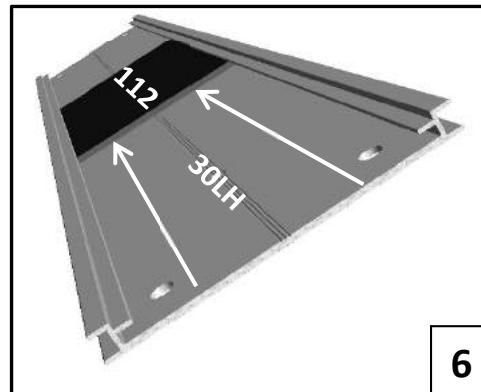
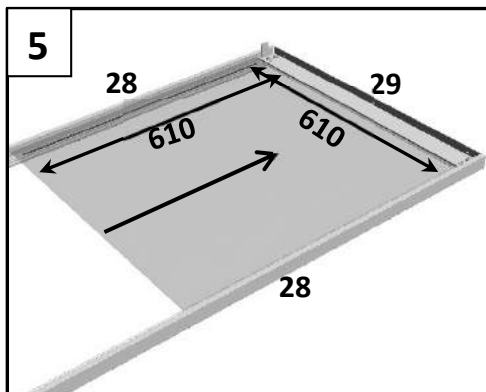
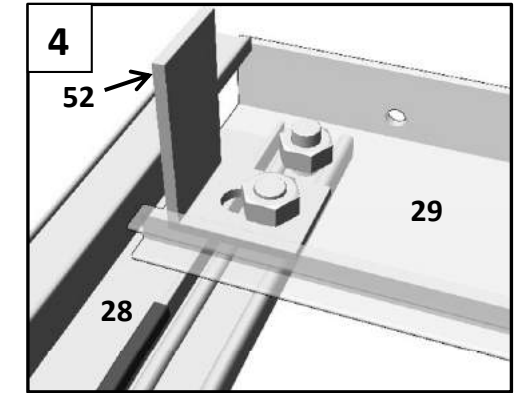
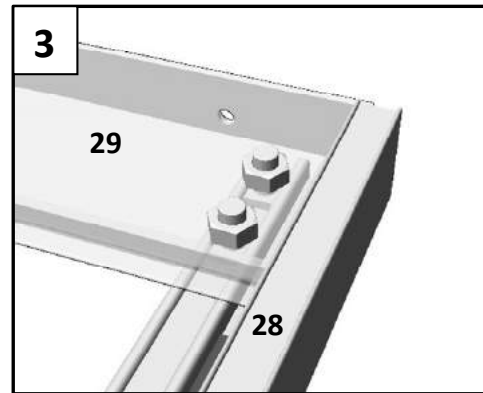
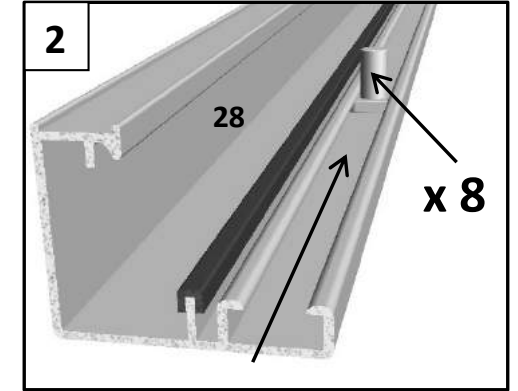
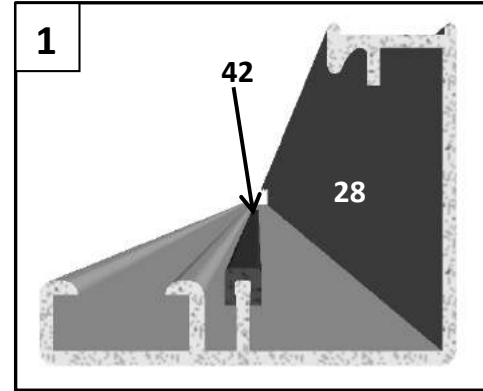
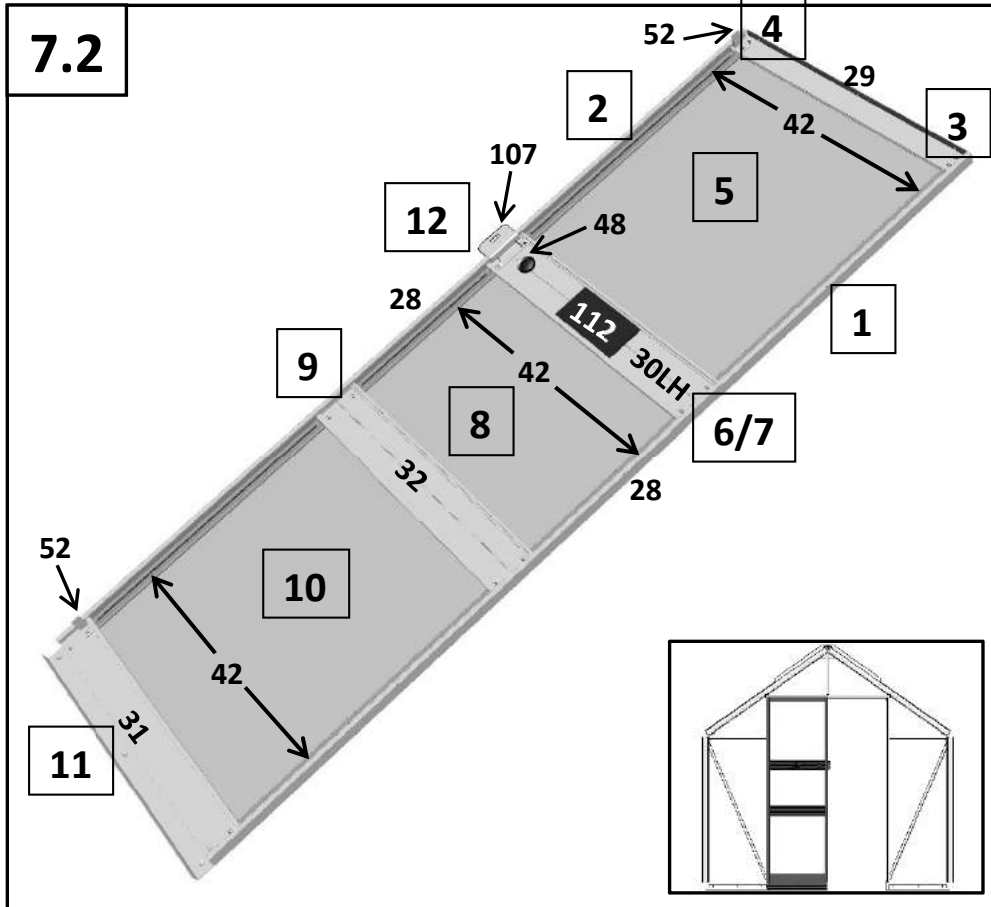

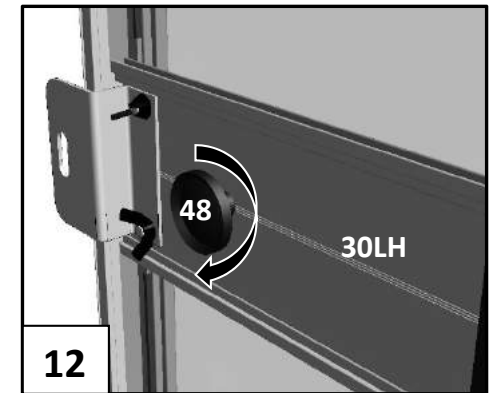
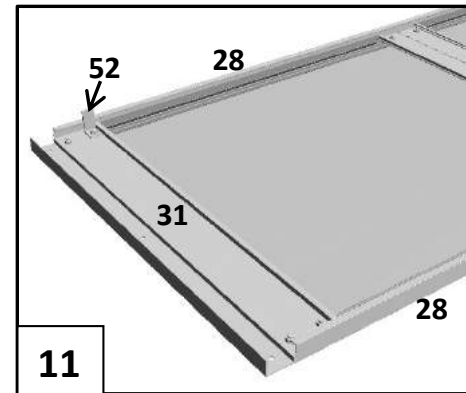
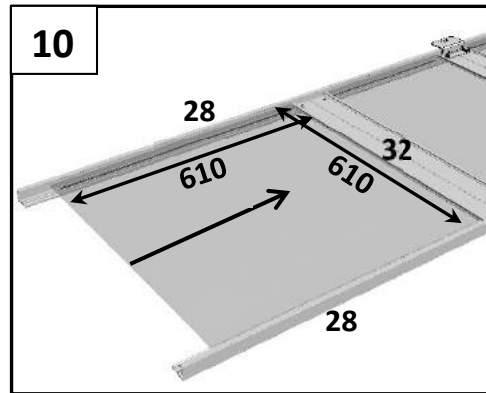
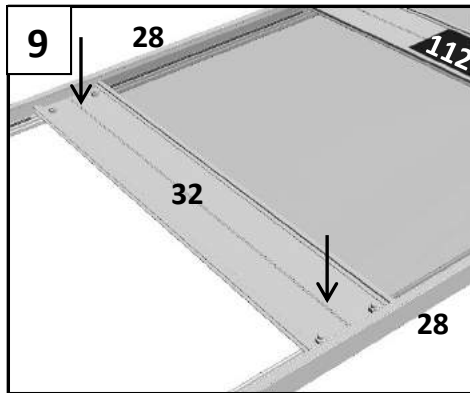

7.3

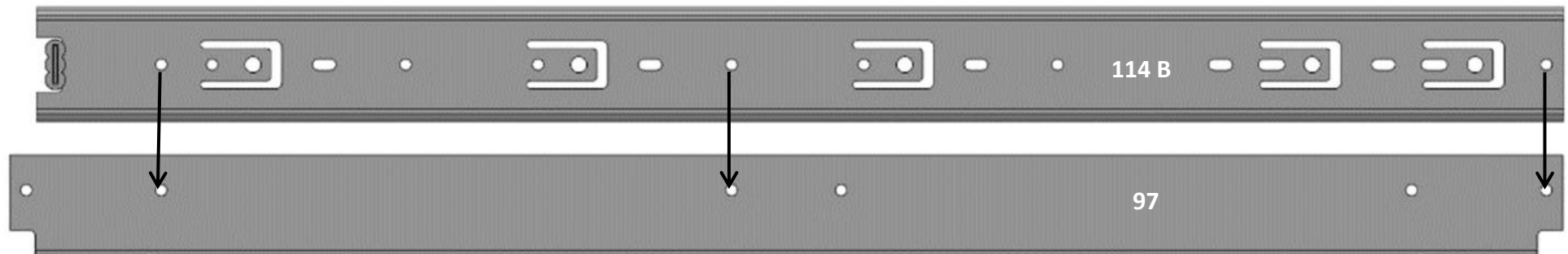
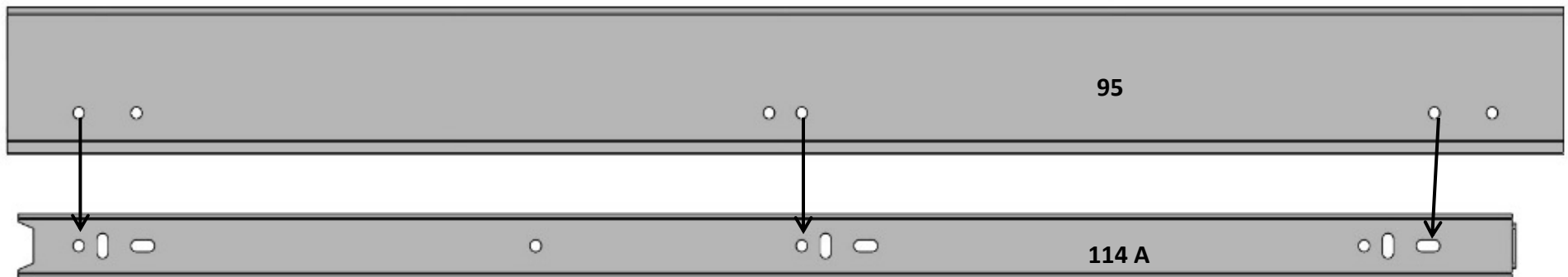
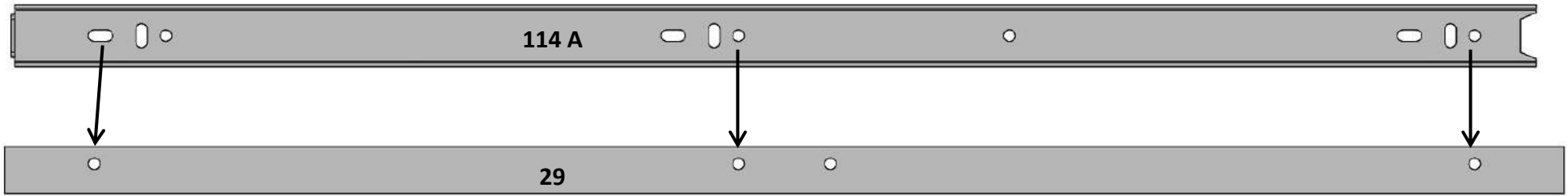

7.4

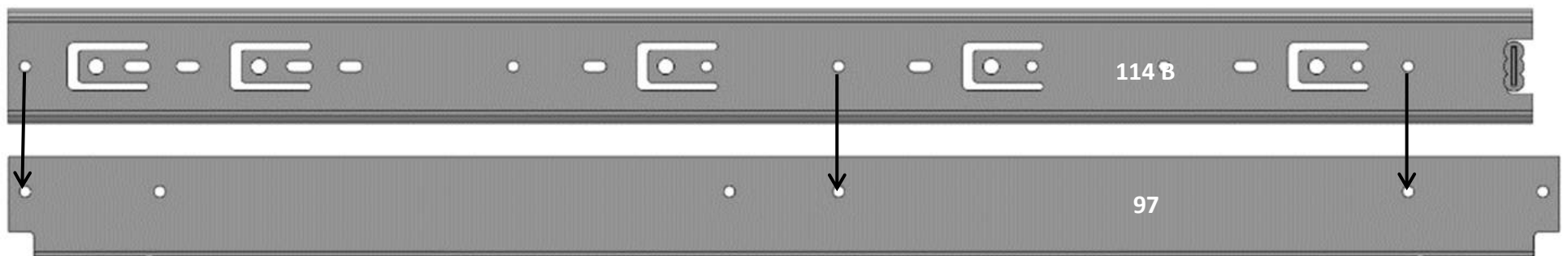
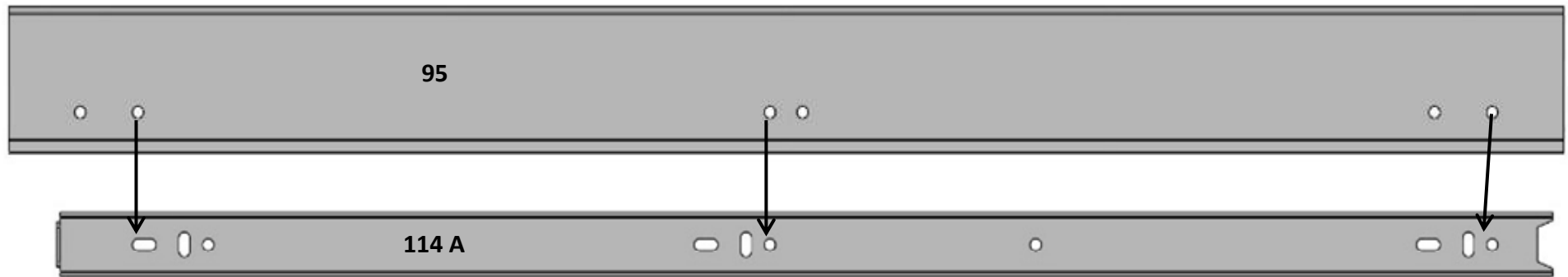
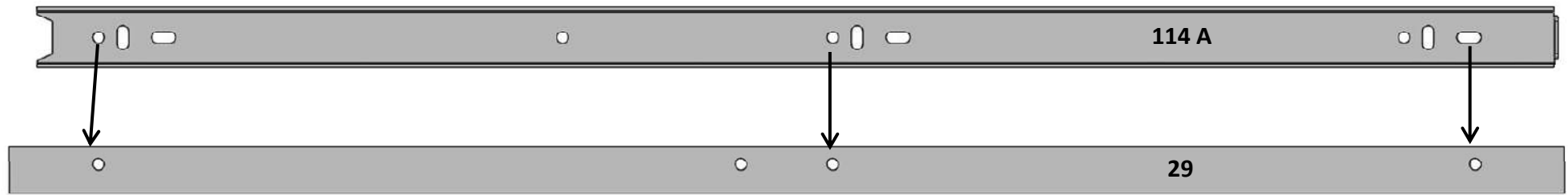

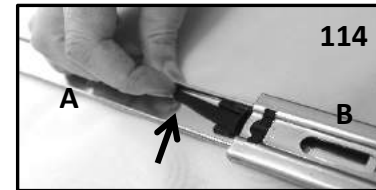
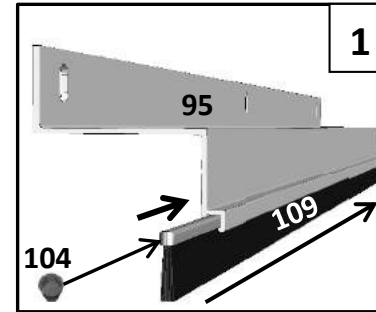
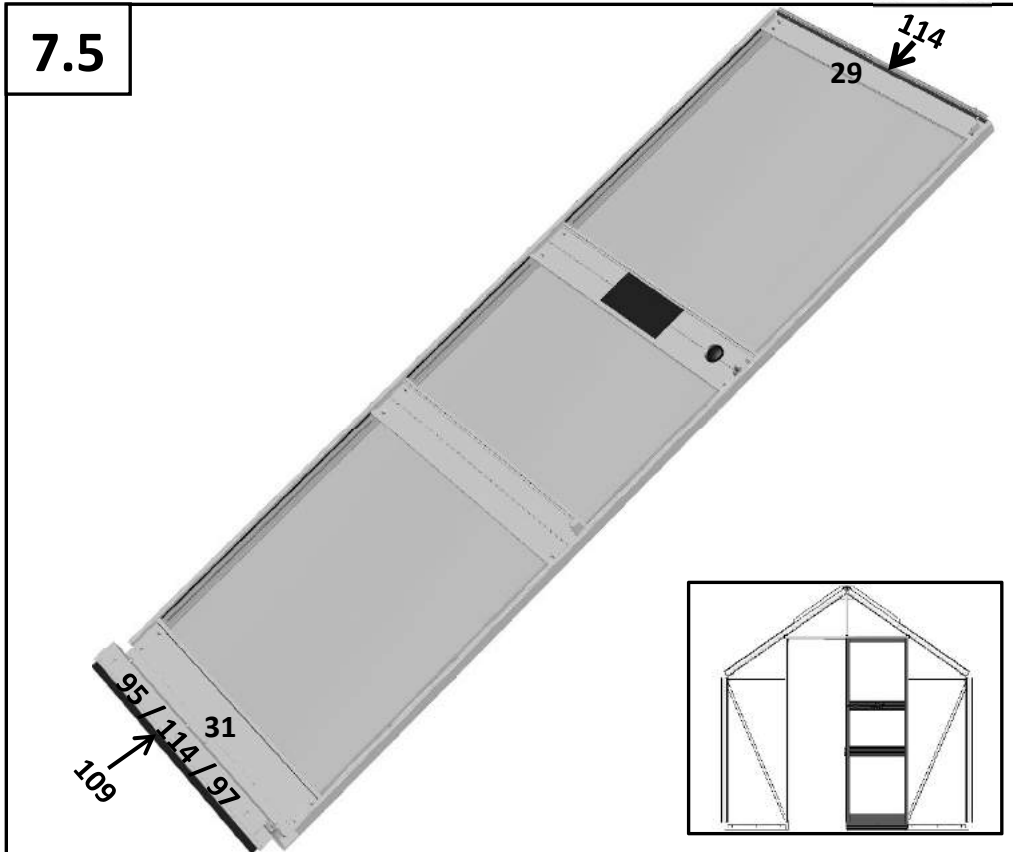

7.5	#	mm	810	812	814	ITEM NO.
	109	610	1	1	1	RN00310420
	104	-	2	2	2	N00300604
	95	620	1	1	1	RP2079100620
	114 A/B	600	2	2	2	RN00310437
	97	360	1	1	1	RP2079120360- RH
	103	-	26	26	26	N00300603
	118	-	26	26	26	01645
	102	-	26	26	26	N00300602

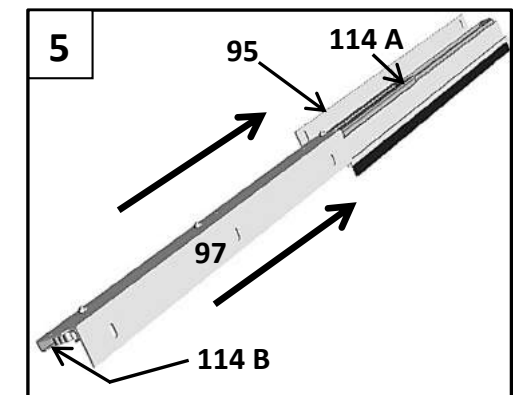
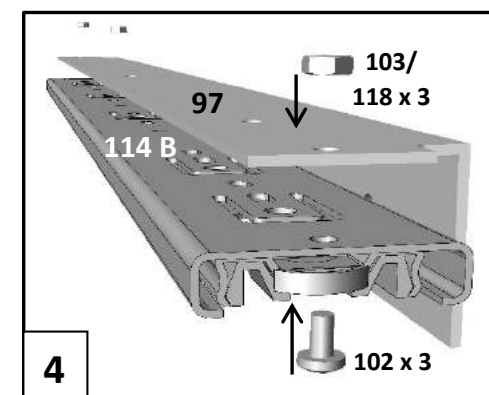
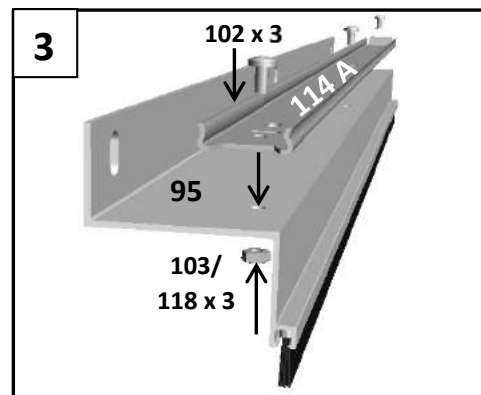
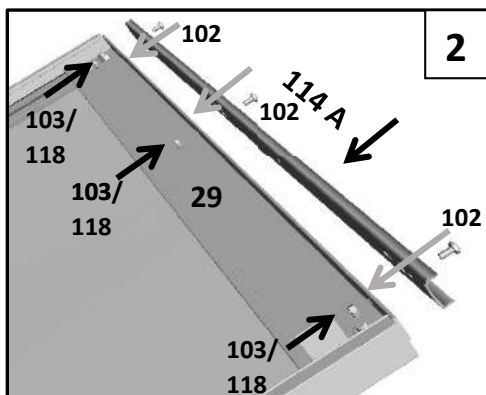
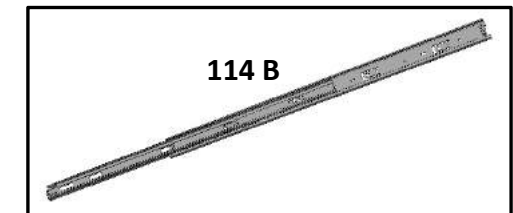
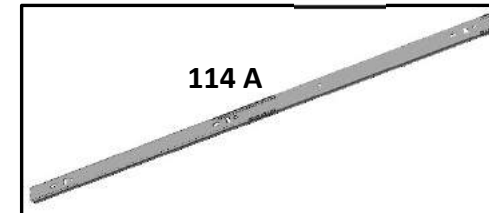
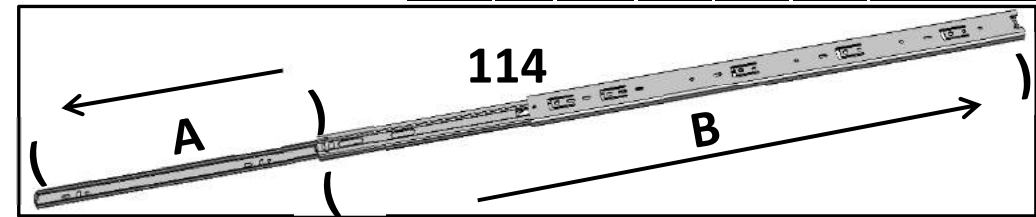

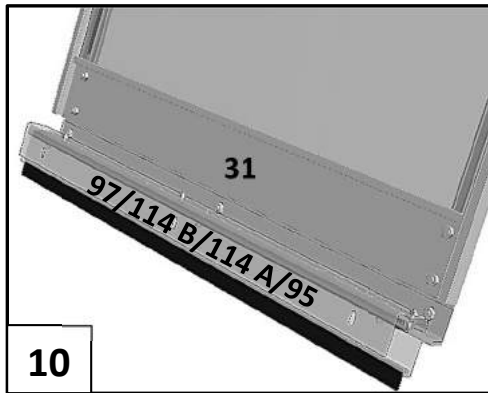
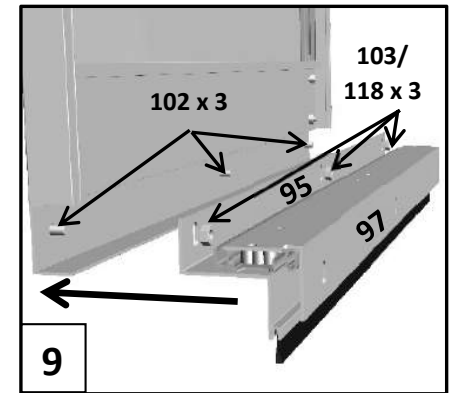
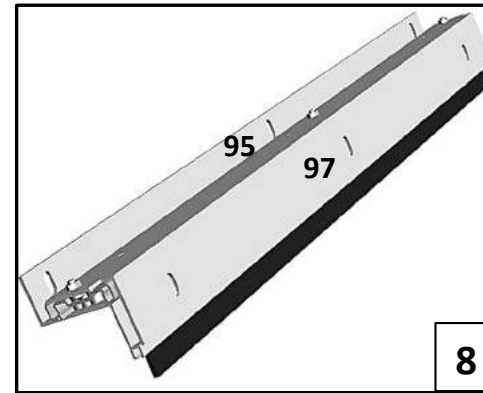
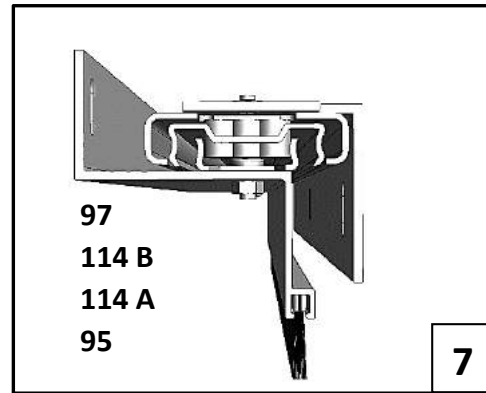
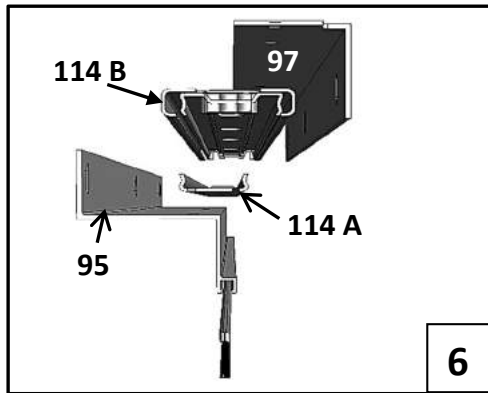

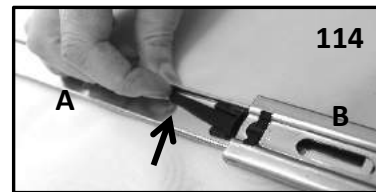
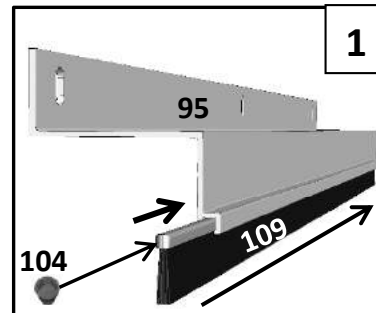
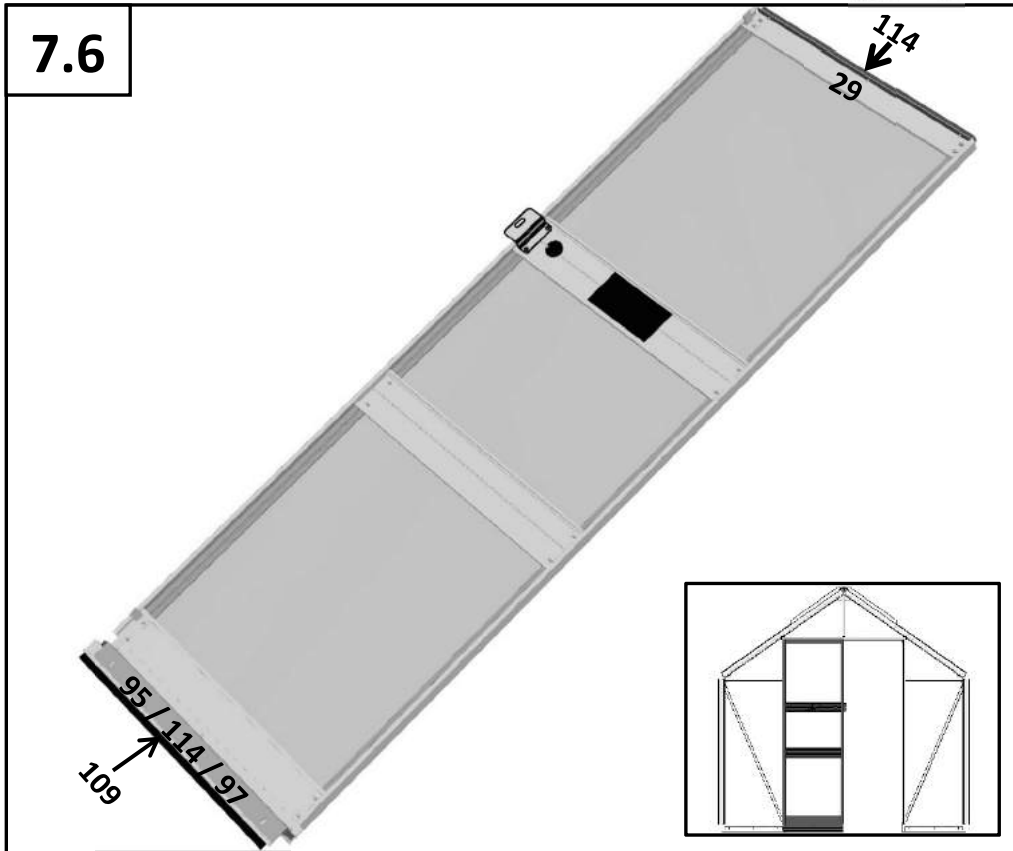

7.6	#	mm	810	812	814	ITEM NO.
	109	610	1	1	1	RN00310420
	104	-	2	2	2	N00300604
	95	620	1	1	1	RP2079100620
	114 A/B	600	2	2	2	RN00310437
	97	610	1	1	1	RP2079120610
	103	-	26	26	26	N00300603
	118	-	26	26	26	01645
	102	-	26	26	26	N00300602

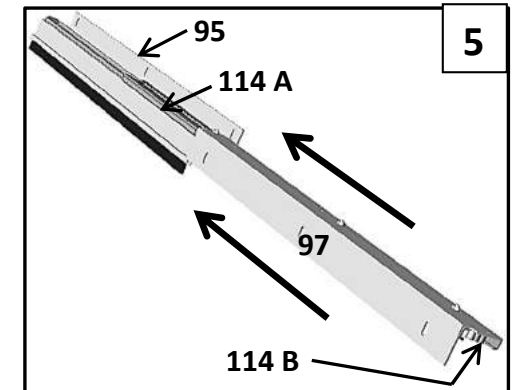
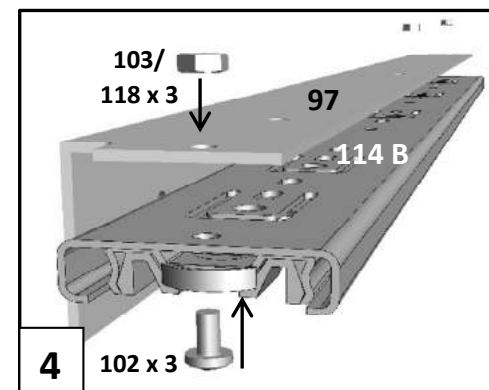
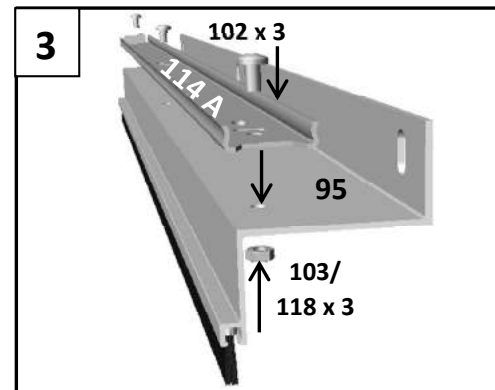
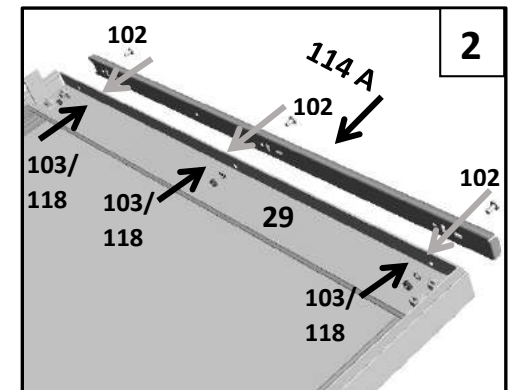
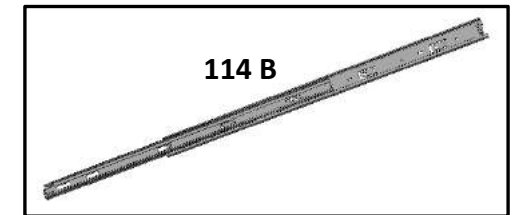
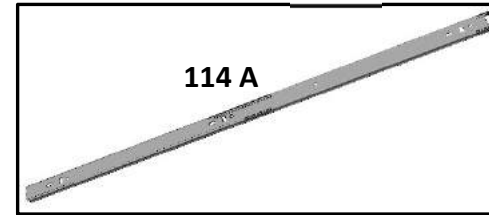
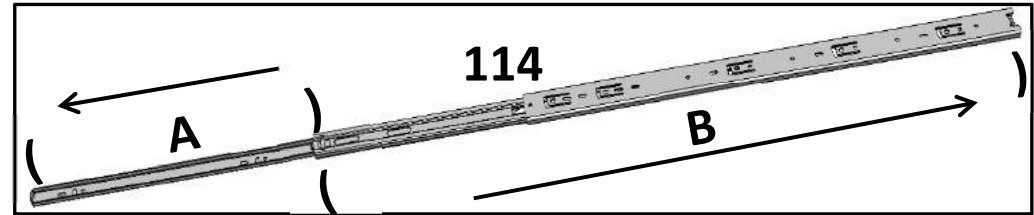

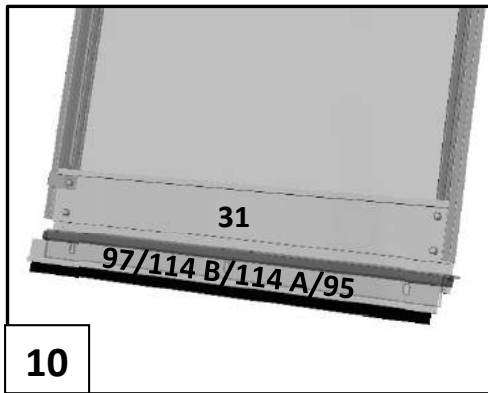
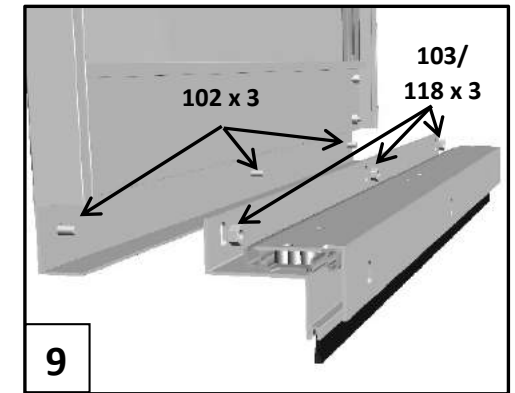
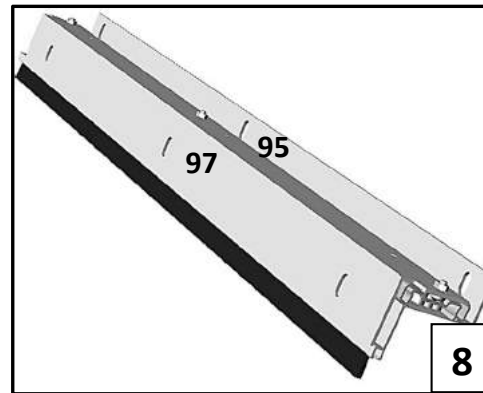
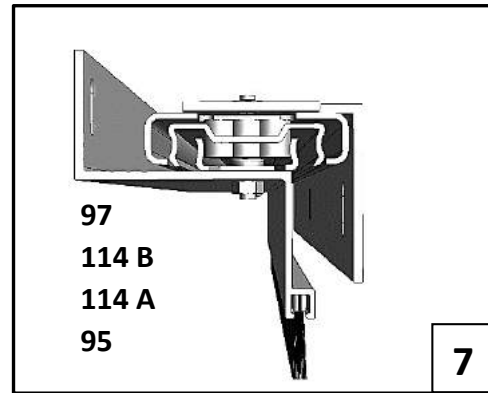
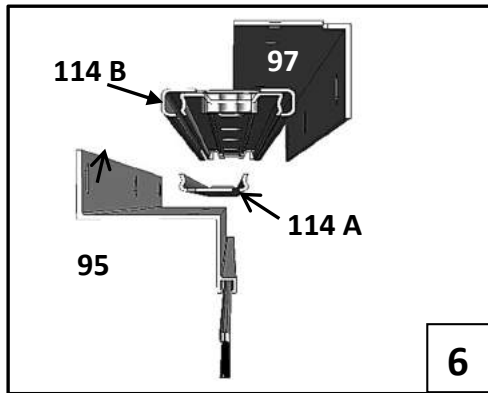

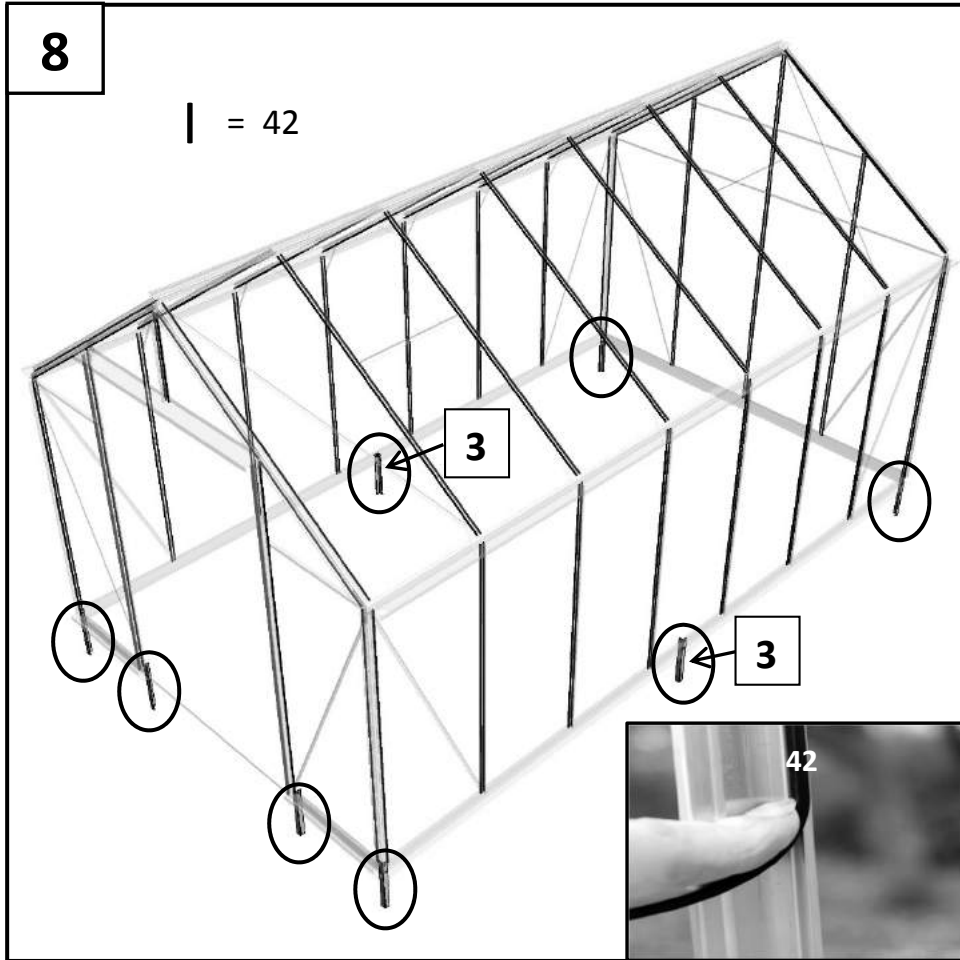

8	#	mm		ITEM NO.
	64	305	8	RP102640305
	98	-	8	N00310020
	42	64000	2	RN00300413

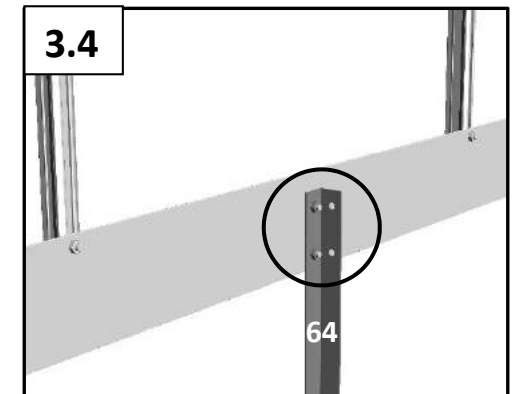
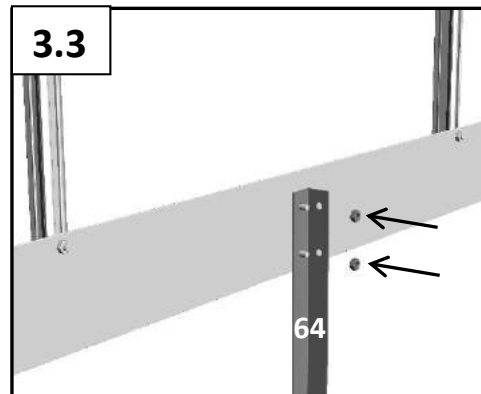
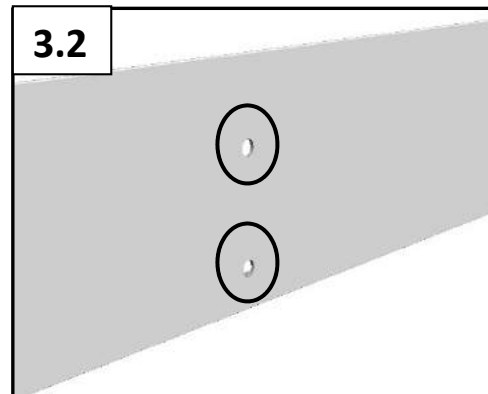
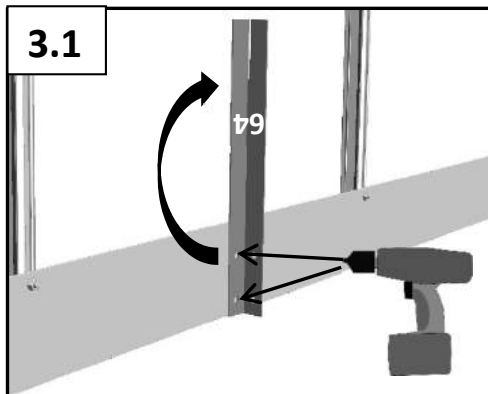
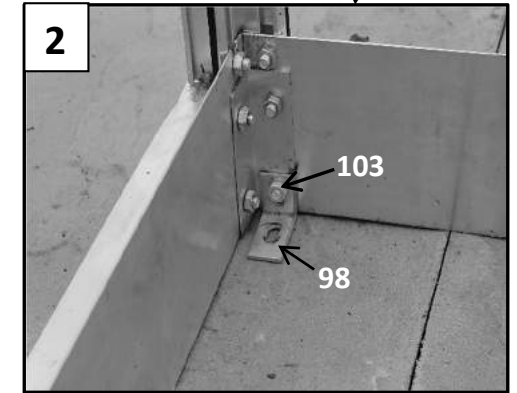
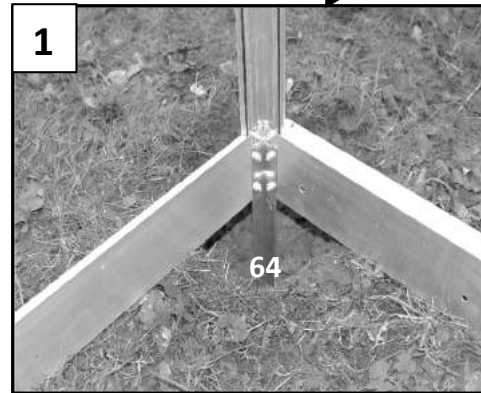
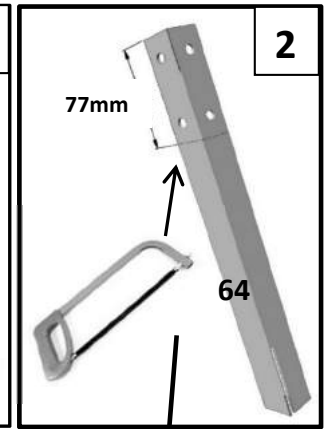
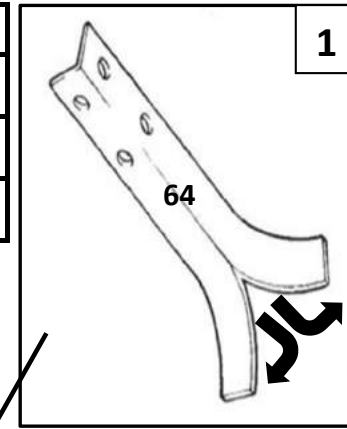

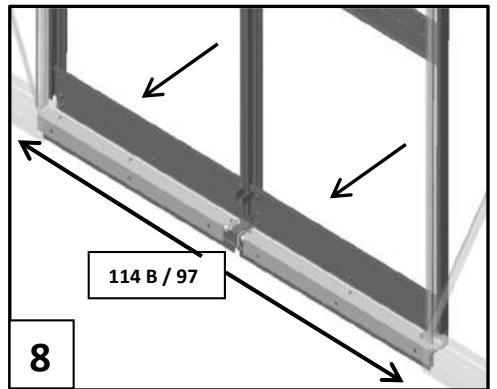
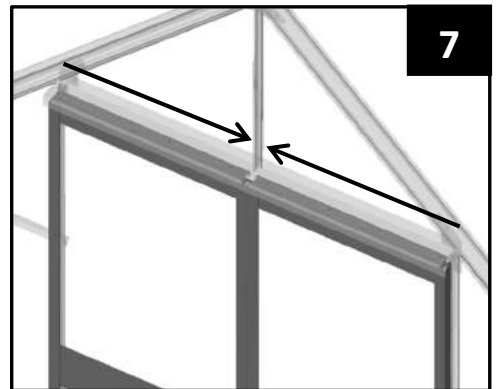
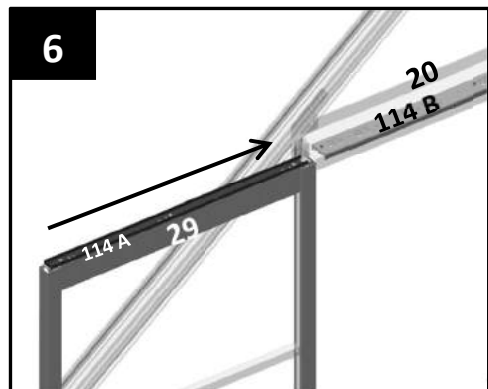
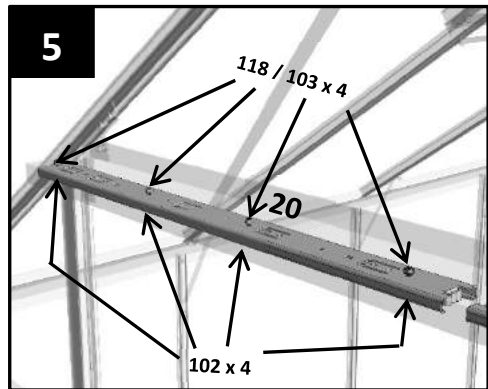
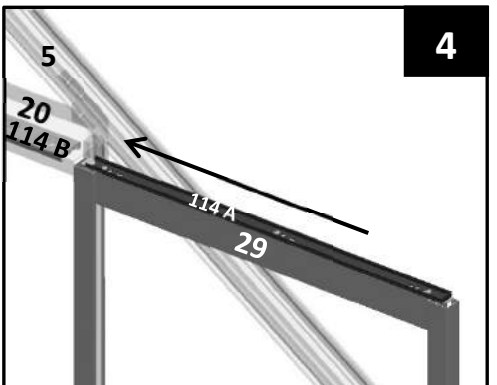
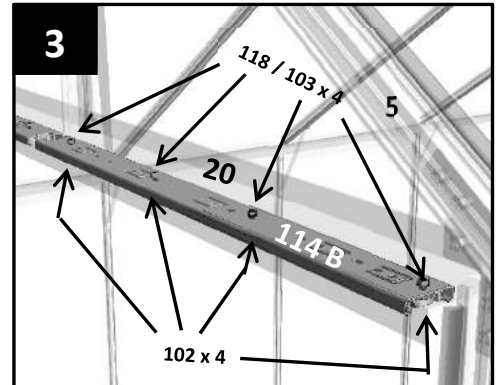
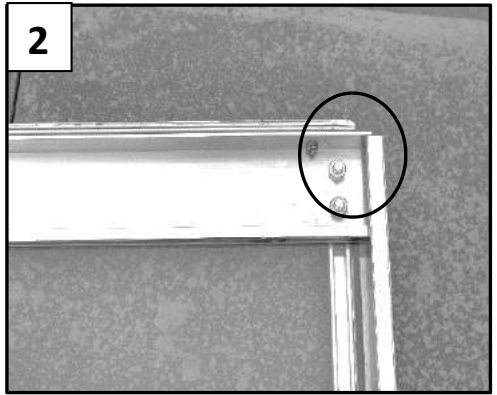
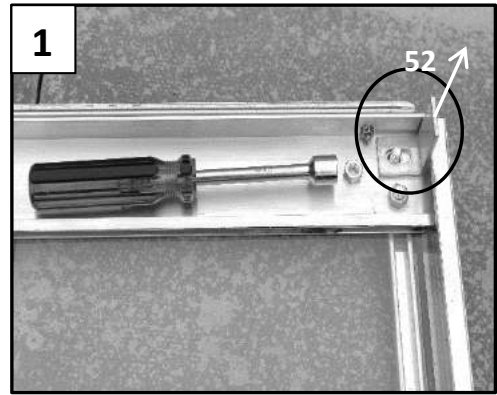
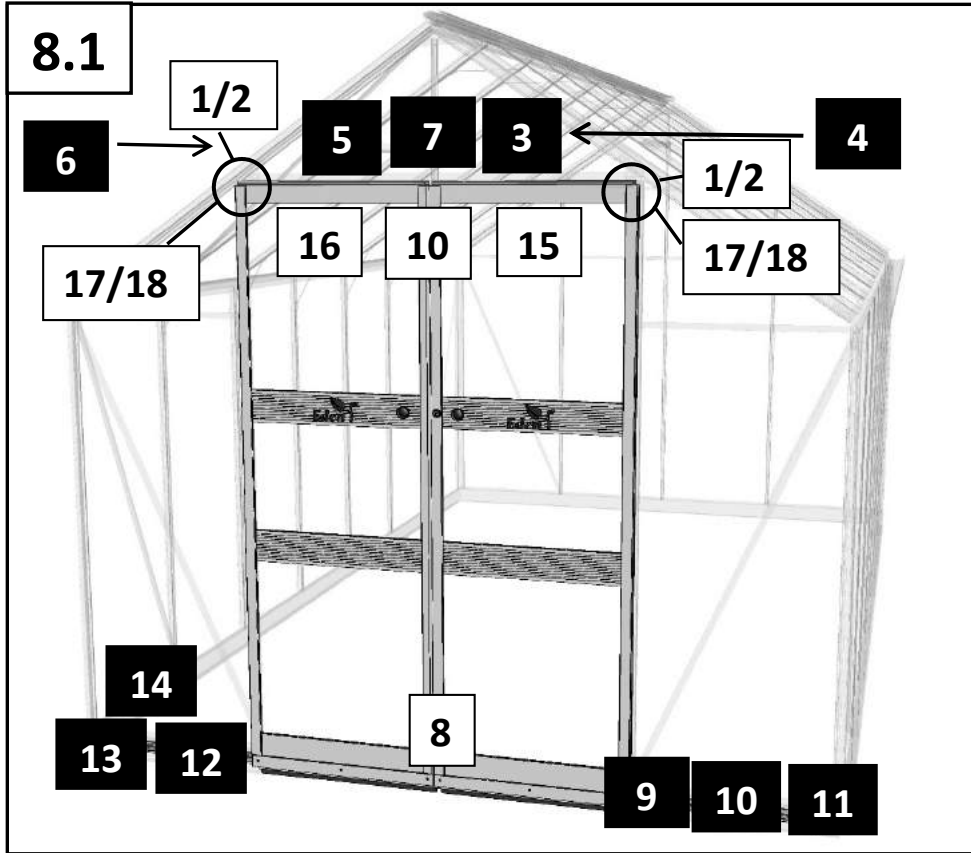

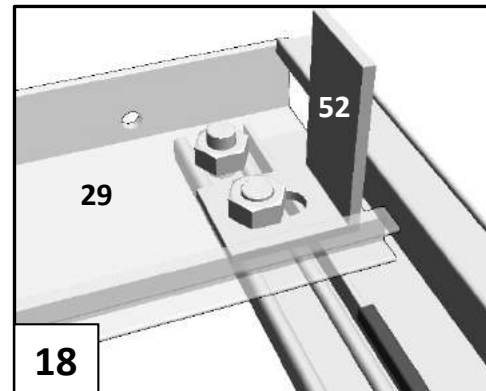
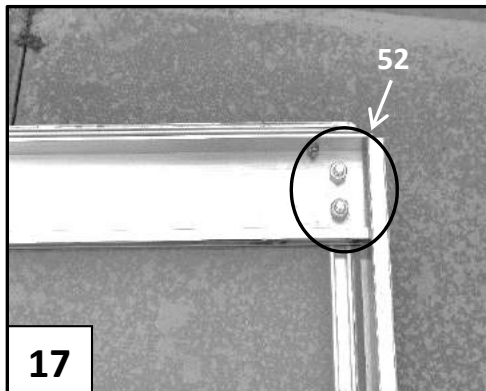
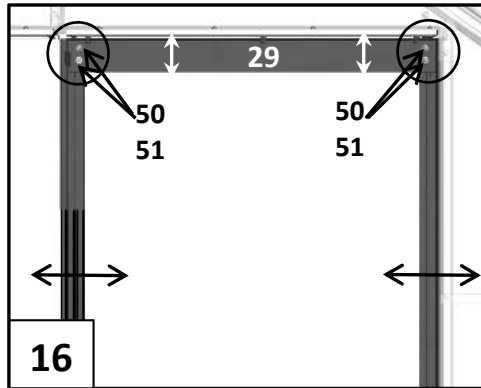
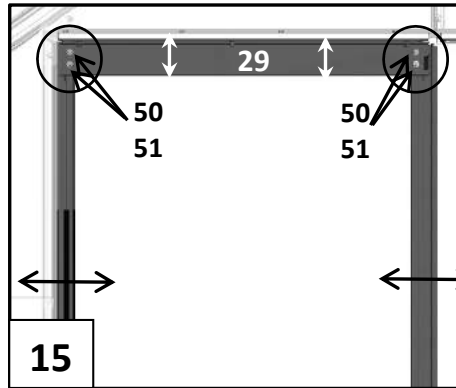
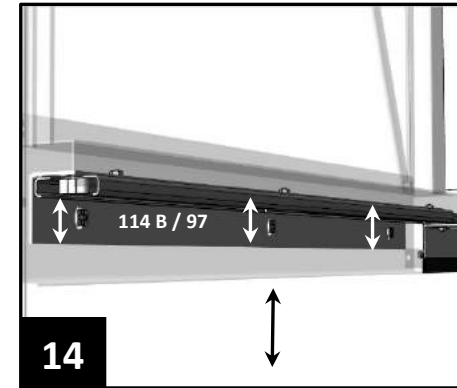
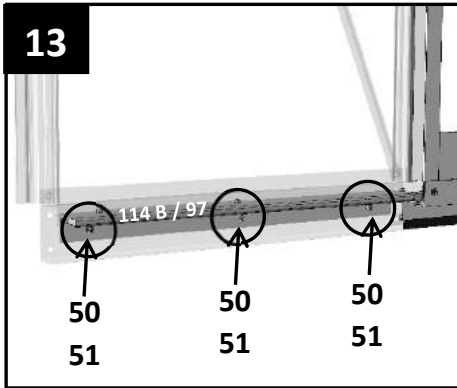
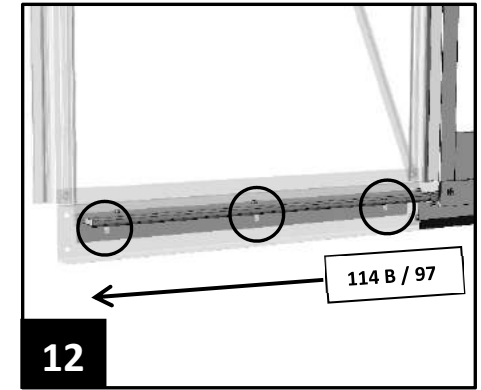
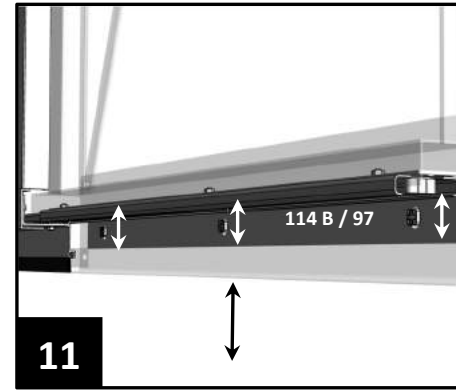
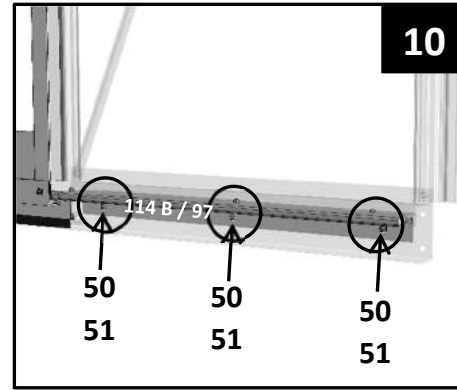
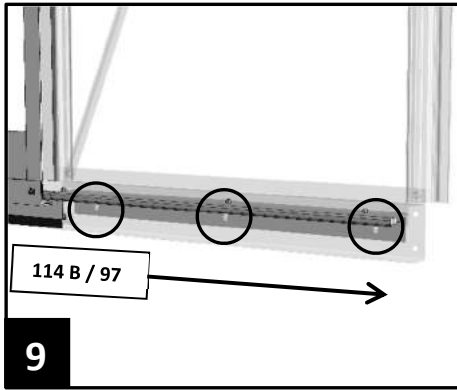

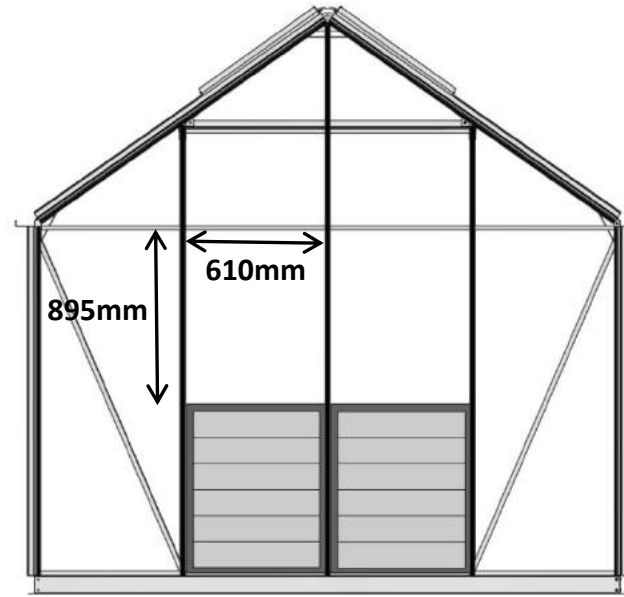
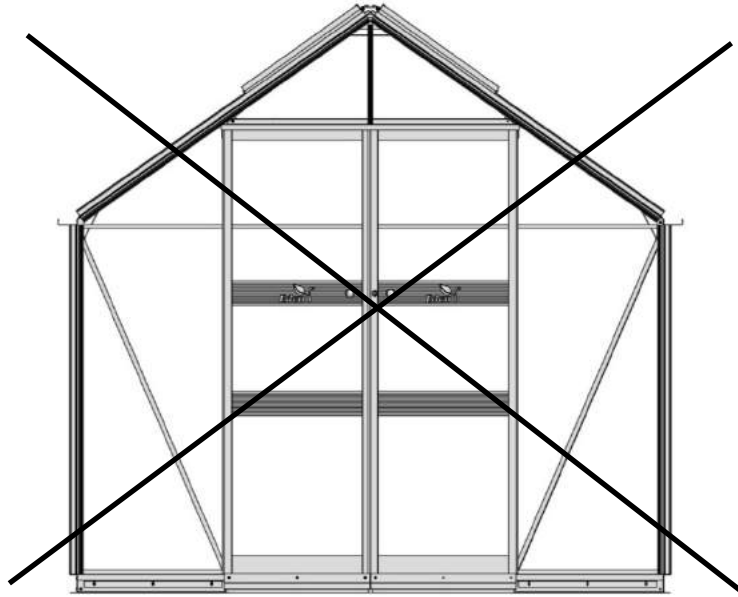

9

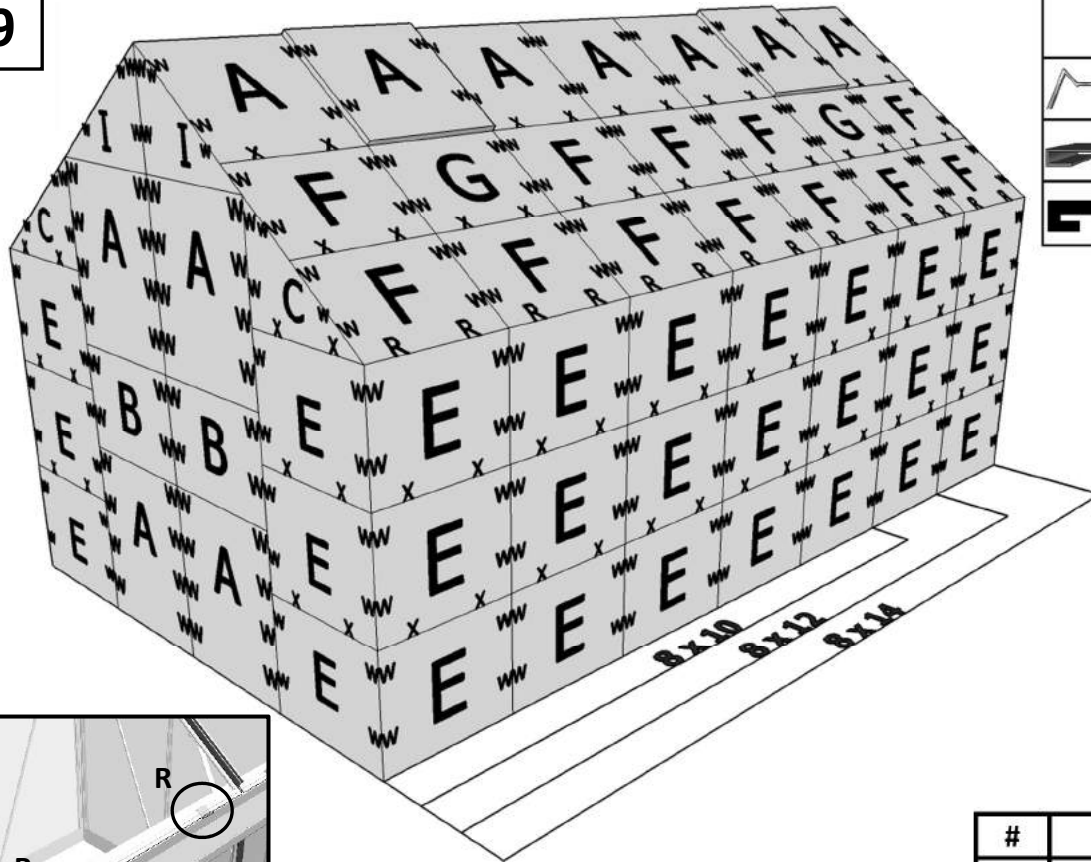

	#	mm
	W	
	X	
	R	

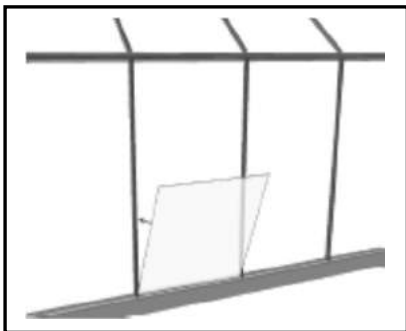
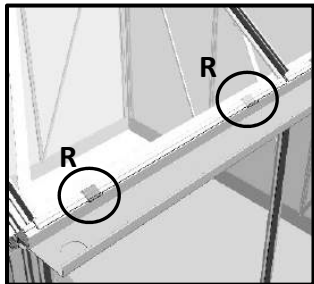
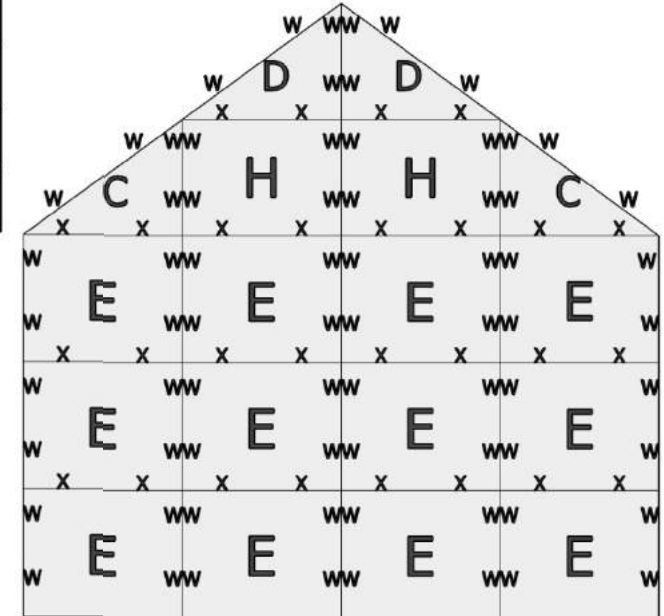

#	mm	8 x 10	8 x 12	8 x 14	No.
A	610 x 610	14	16	18	10155
B	610 x 374	2	2	2	GLH 1028
C	610 x 453 x 20	4	4	4	GL 9150
D	610 x 445 x 12	2	2	2	GL 9151
E	610 x 504	48	54	60	10221
F	610 x 467	4	6	6	GL 1025
G	610 x 457	2	2	2	10140
H	610 x 457	2	2	2	10140
I	610 x 434 x 12	2	2	2	GLH 1029
W	-	450	450	450	N00300205
X	-	150	150	150	N00300210
R	-	20	24	28	RN00310458

9

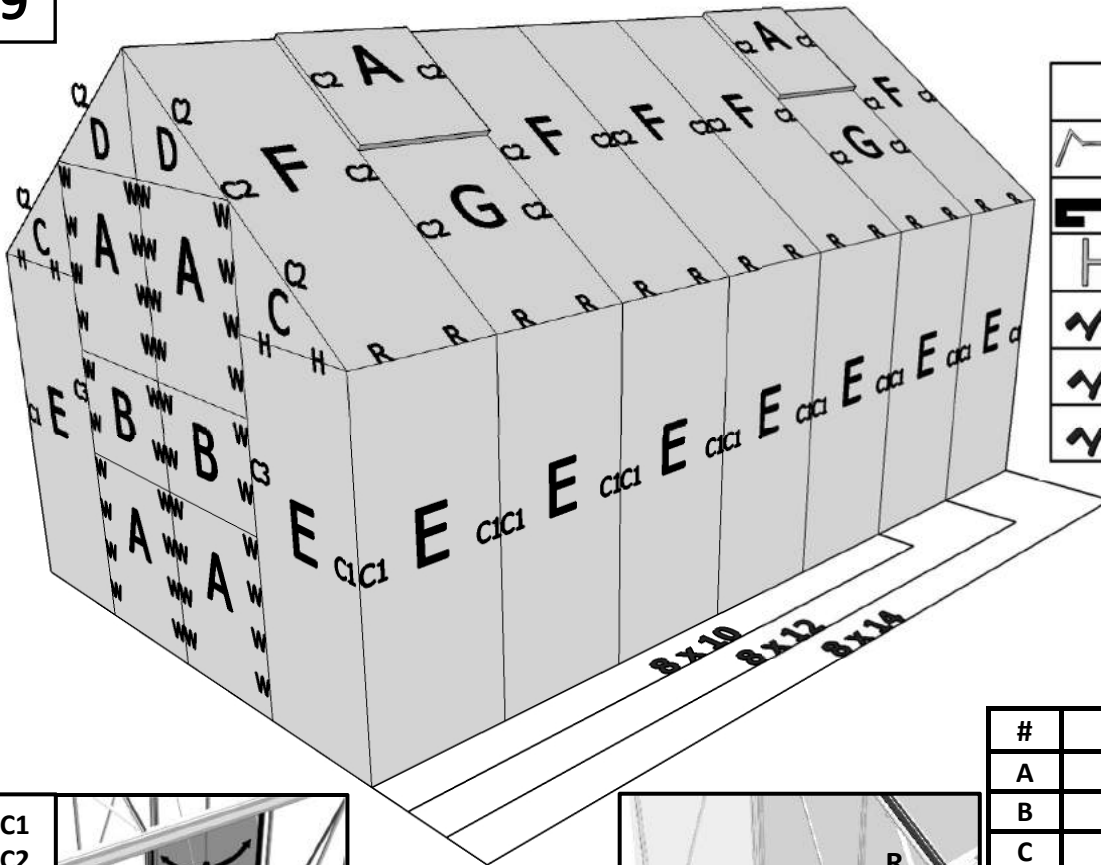

	#	mm
	W	
	R	
	H	610
	C1	1490
	C2	1490
	C3	1920

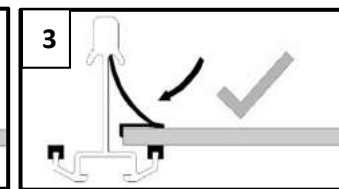
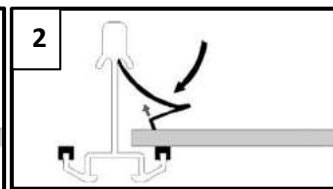
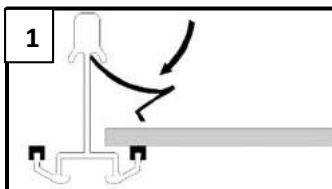
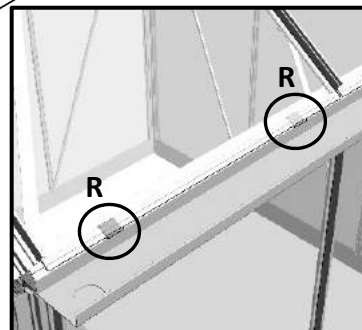
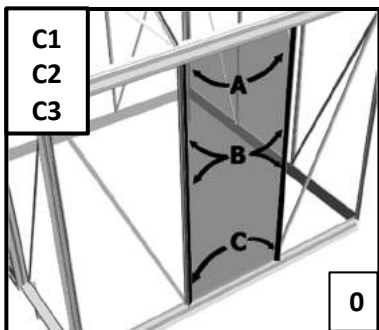
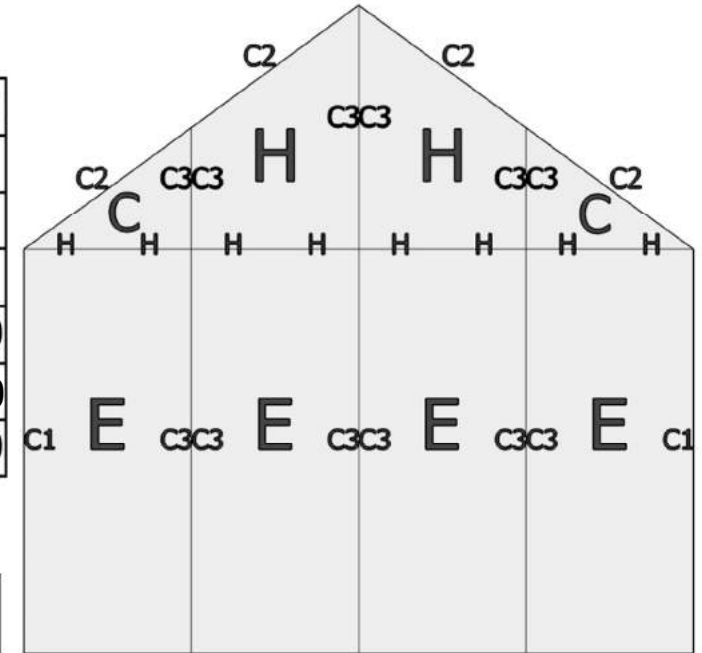

#	mm	8 x 10	8 x 12	8 x 14	No.
A	610 x 610	4	4	6	10032
B	610 x 374	2	2	2	GLT 3047
C	610 x 445 X 12	4	4	4	GLT 3027
D	610 x 434 x12	2	2	2	GLT 3052
E	610 x 1486	16	18	20	10225
F	610 x 1525	6	8	10	GLT 3051
G	610 x 910	4	4	4	GL 9009
H	610 x 878 x 451	2	2	2	GLT 3046
C1	1490	24	28	32	RN00311417
C2	1490	24	28	32	RN00311417
C3	1920	8	8	8	RN00311416
H	610	6	6	6	12467
W	-	450	450	450	N00300205
R	-	20	24	28	RN00310458

9

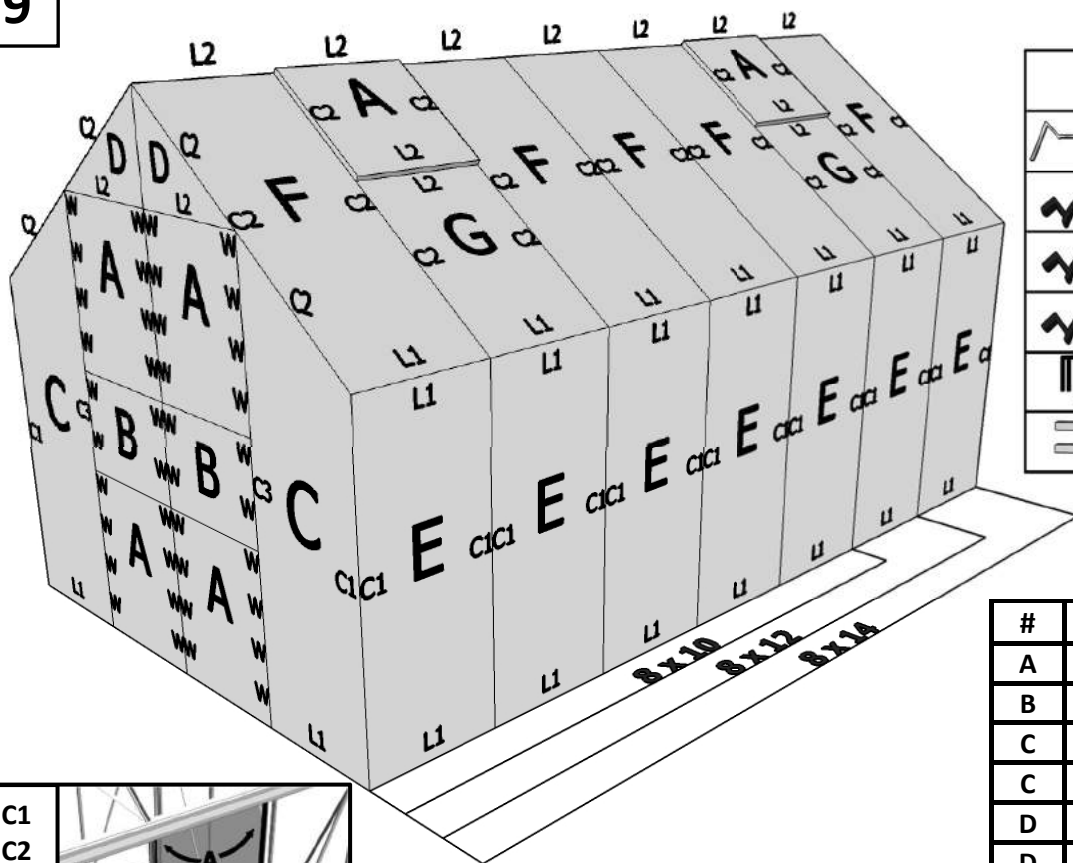

	#	mm
	W	
	C1	1490
	C2	1490
	C3	1920
	L1	590
	L2	590

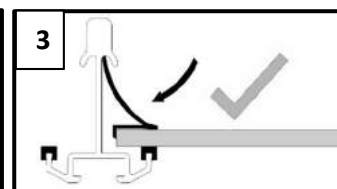
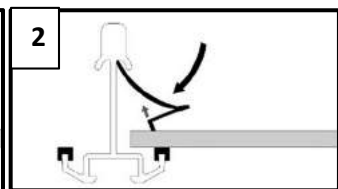
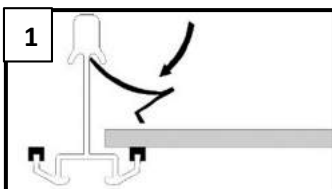
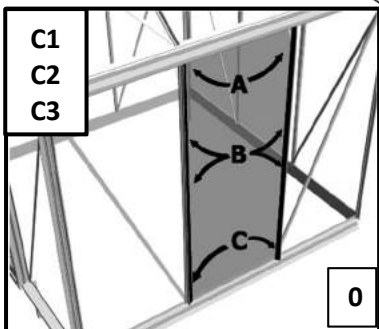
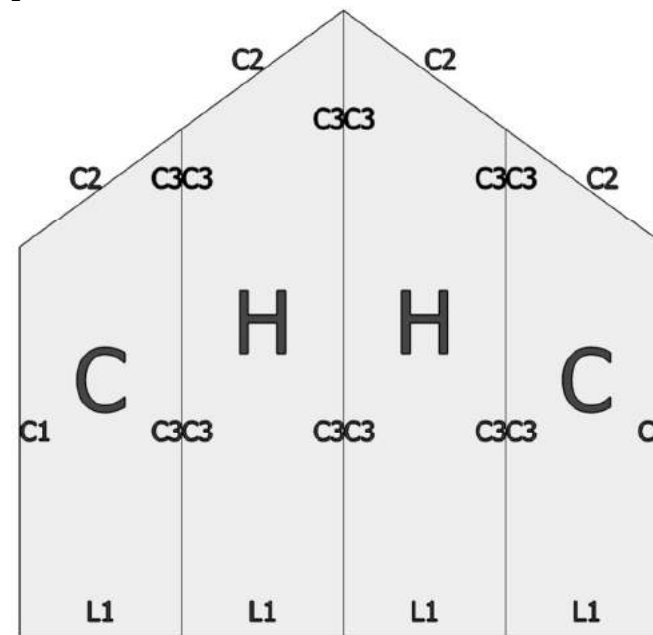

#	mm	8 x 10	8 x 12	8 x 14	No.
A	610 x 610	8	8	8	RN00311220
B	610 x 374	2	2	2	RN00311233
C	610 x 1504 x 1932 LH	2	2	2	RN00311296
C	610 x 1932 x 1504 RH	2	2	2	RN00311297
D	610 x 15 x 433 LH	1	1	1	RN00311298
D	610 x 433 x 15 RH	1	1	1	RN00311299
E	610 x 1480	10	12	14	RN00311217
F	610 x 1505	6	8	10	RN00311252
G	610 x 892	4	4	4	RN00311215
H	610 x 1935 x 2363 LH	1	1	1	RN00311300
H	610 x 2363 x 1935 RH	1	1	1	RN00311301
C1	1490	24	28	32	RN00311417
C2	1490	24	28	32	RN00311417
C3	1920	8	8	8	RN00311416
L1	590	36	42	48	RN00311503
L2	590	20	22	24	20240
W	-	450	450	450	N00300205

Finishing

Blockley

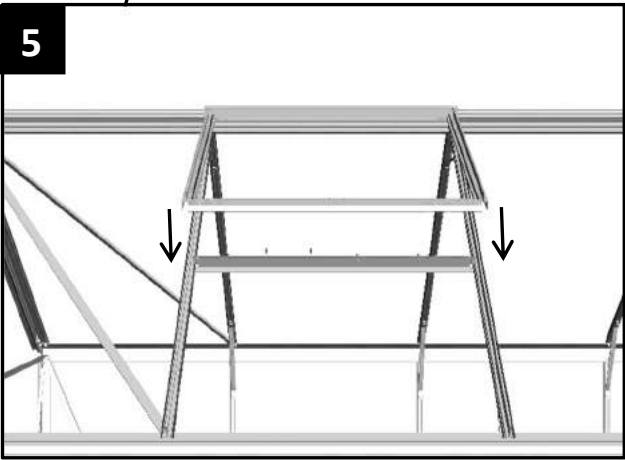
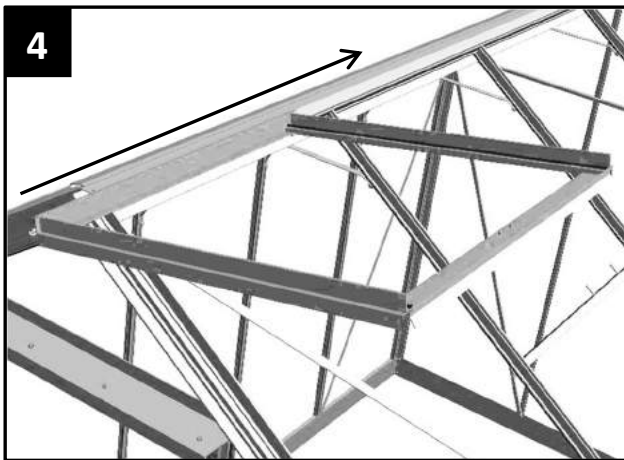
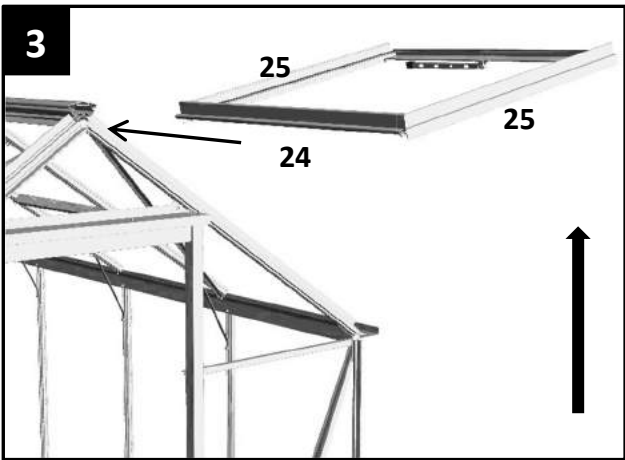
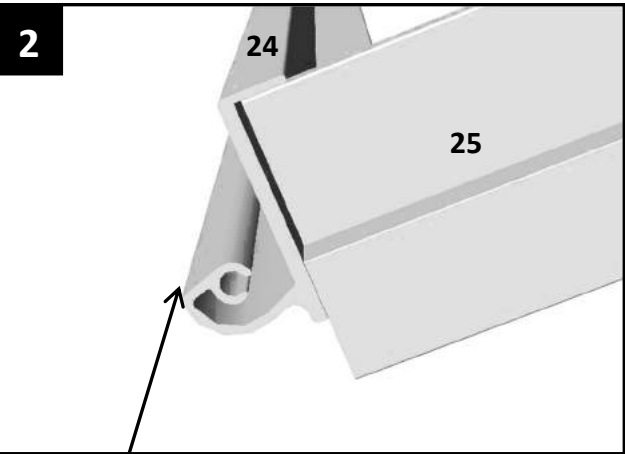
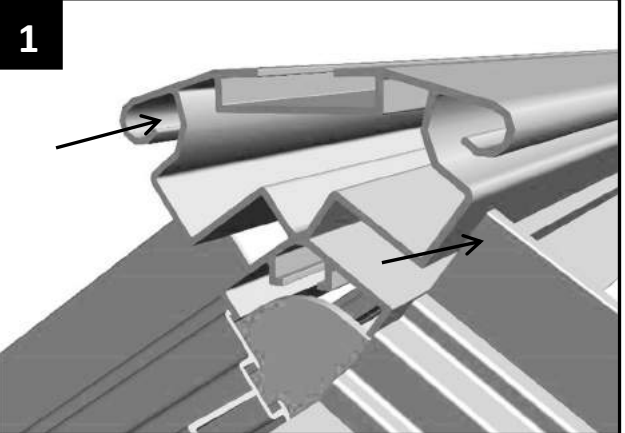
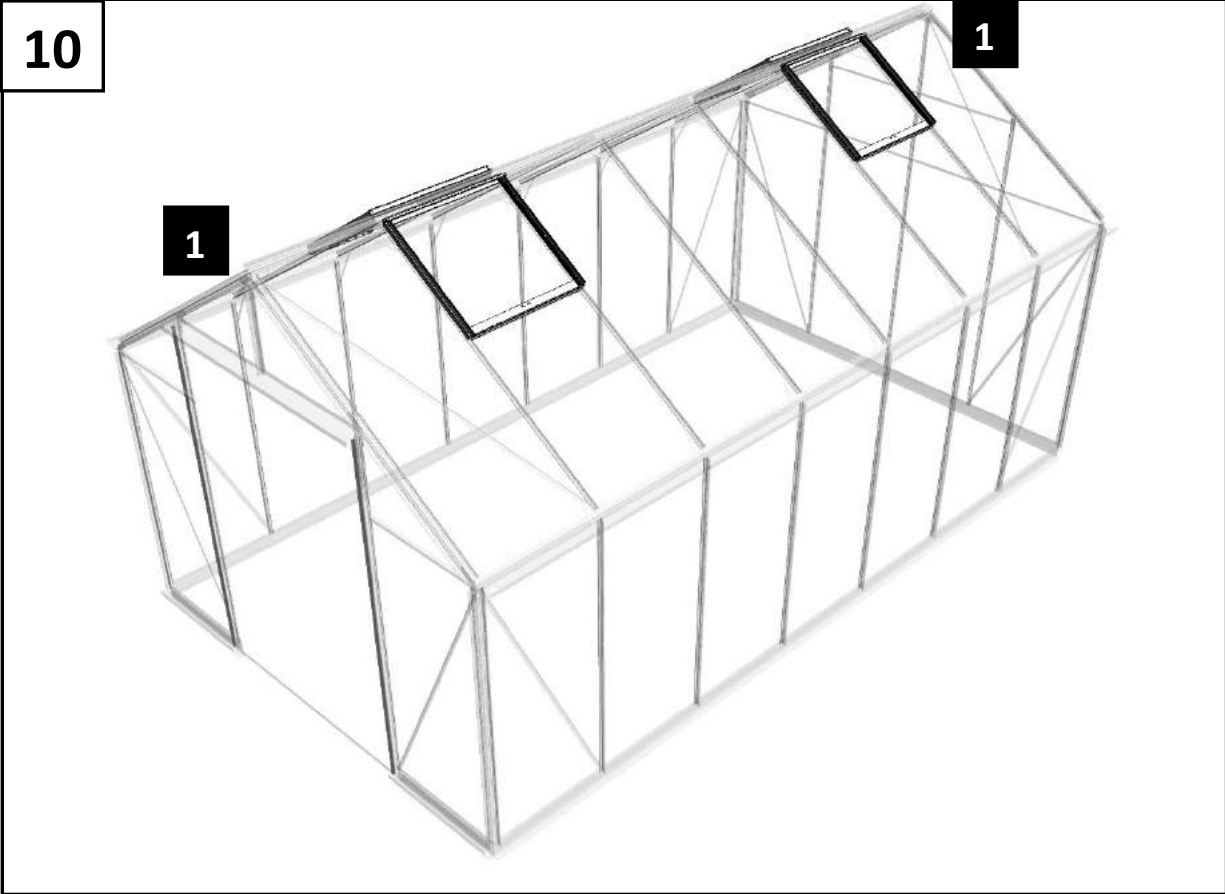

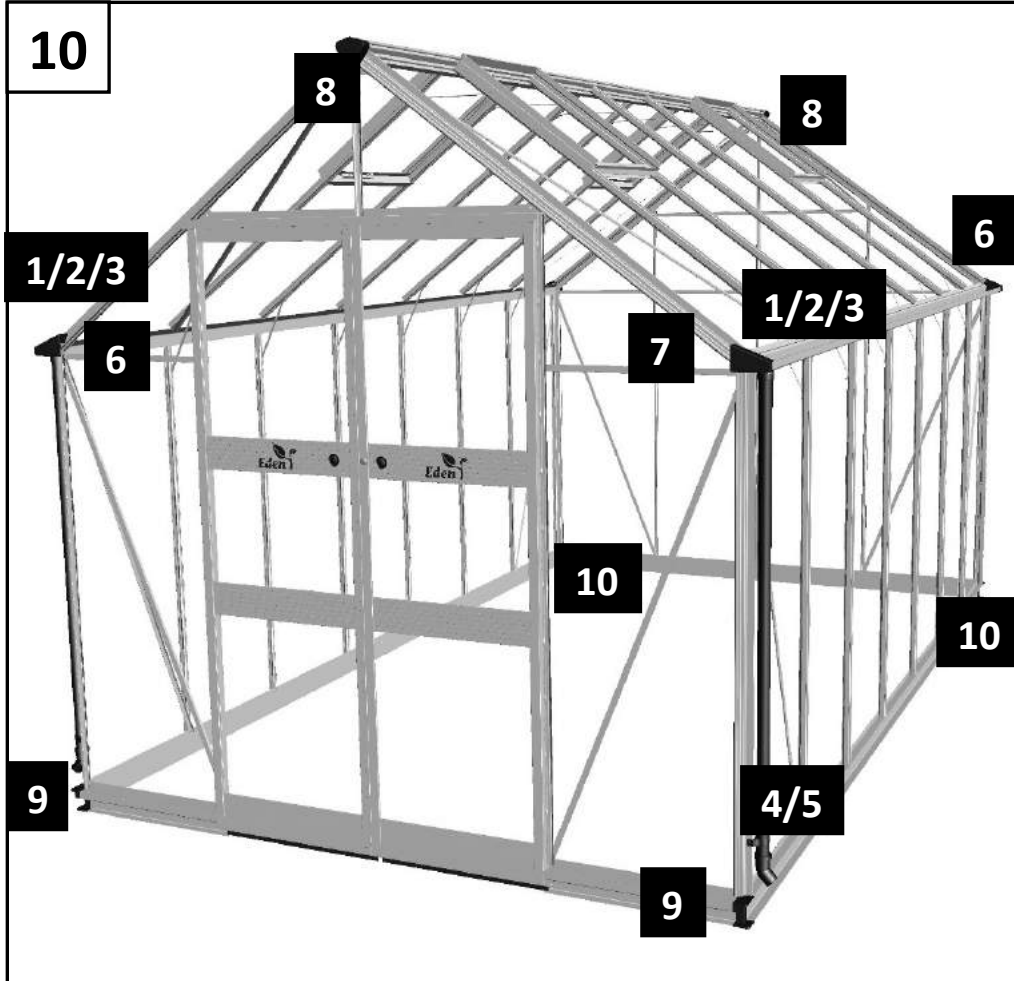

10	#	mm	66/68/610	ITEM NO.
	53	-	2	RN00310453
	54	-	2	RN00310454
	74	-	2	RN00310450
	100	-	6	00402
	101	-	2	N00300422
	105	-	2	PT200
	113	1400	2	RN00310428
	115	-	2	RN00310462
	116	-	1	RN00310463
	117	-	1	RN00310464
	121	-	2	PT201

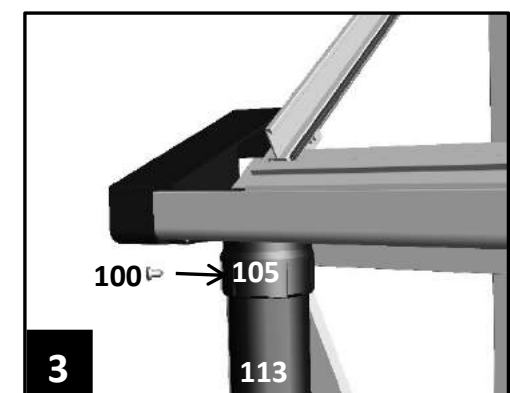
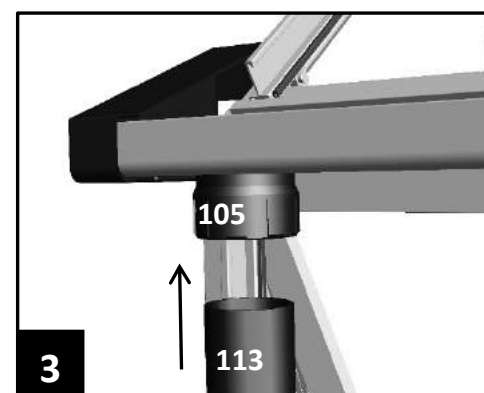
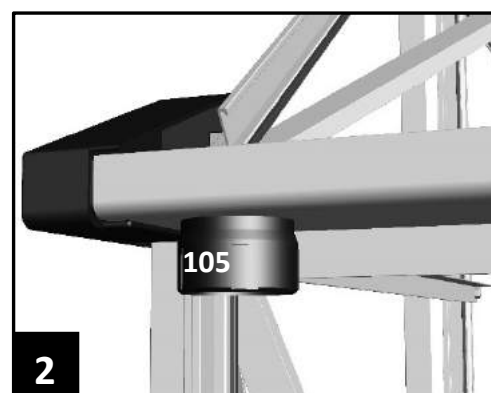
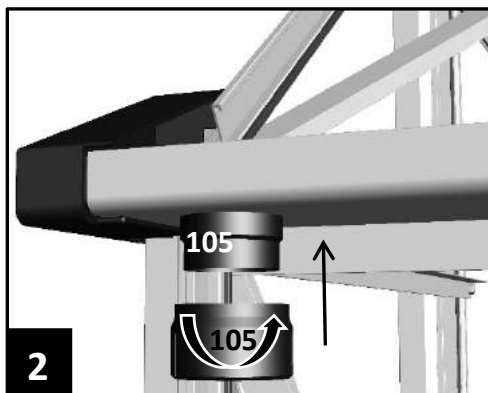
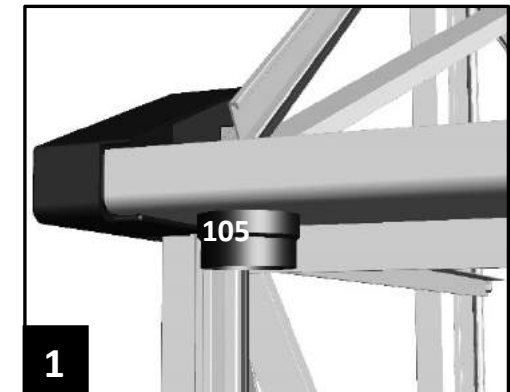
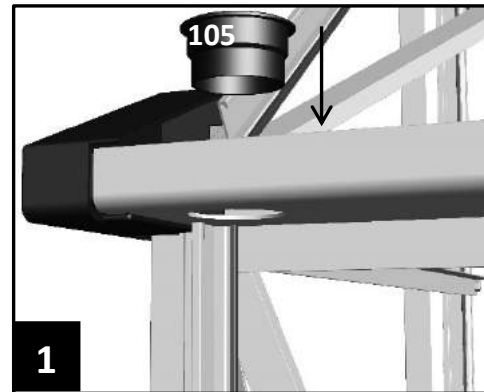

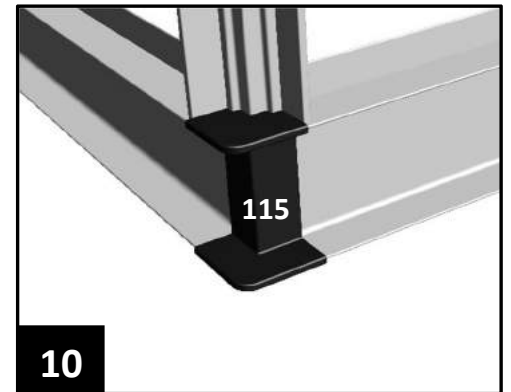
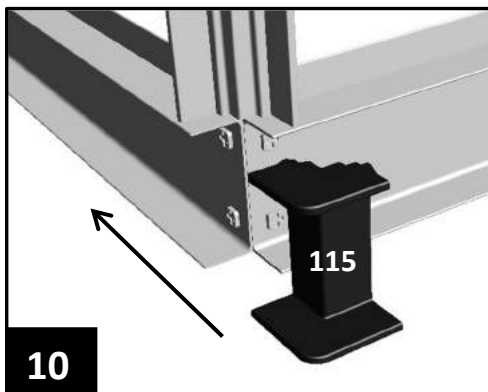
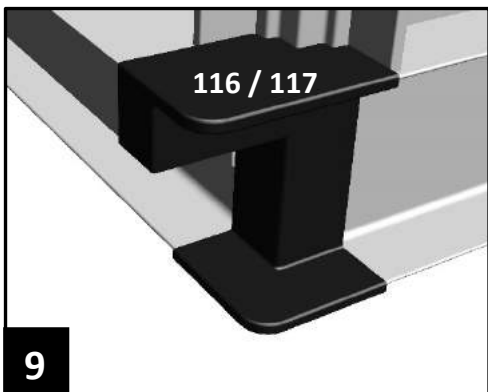
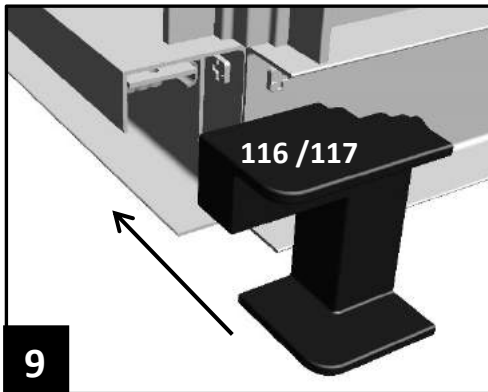
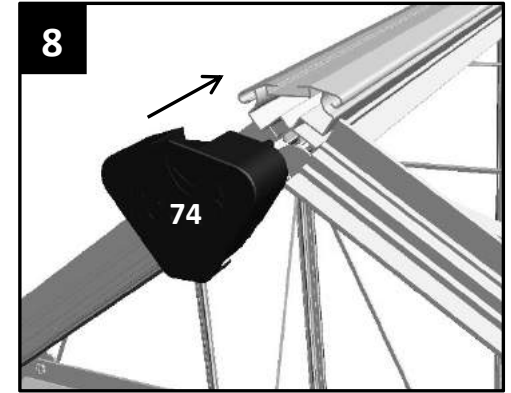
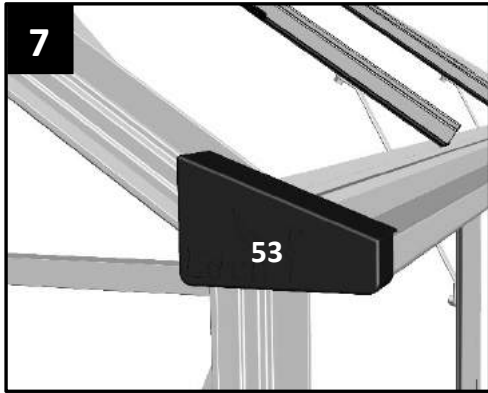
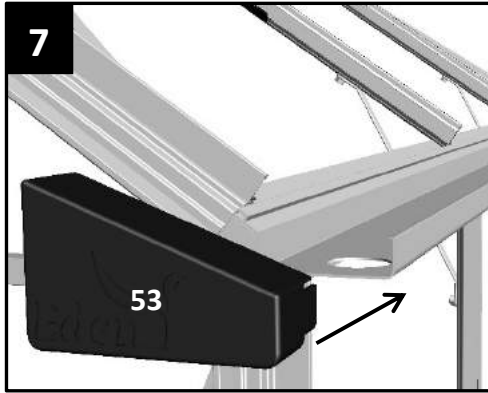
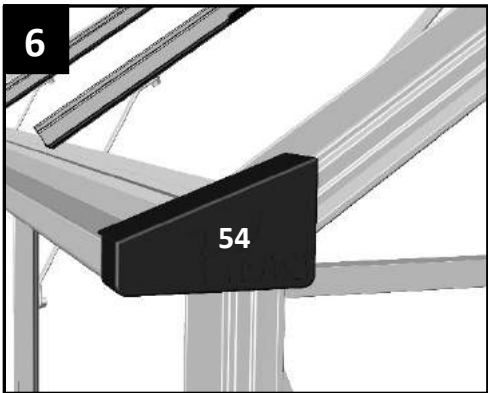
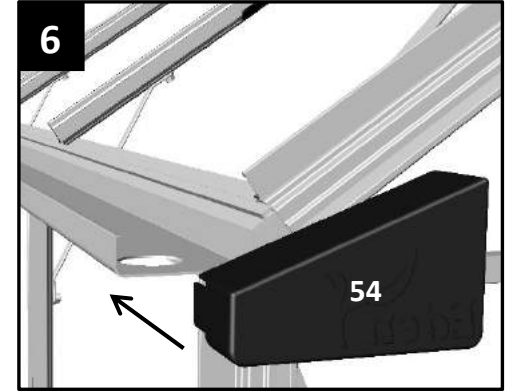
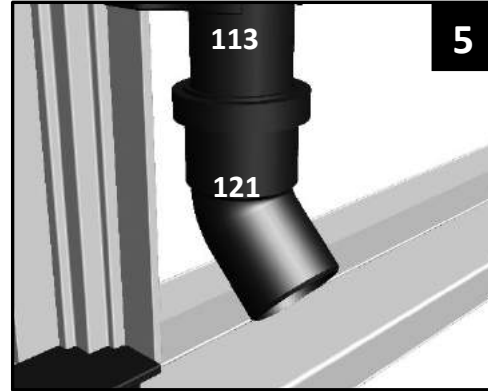
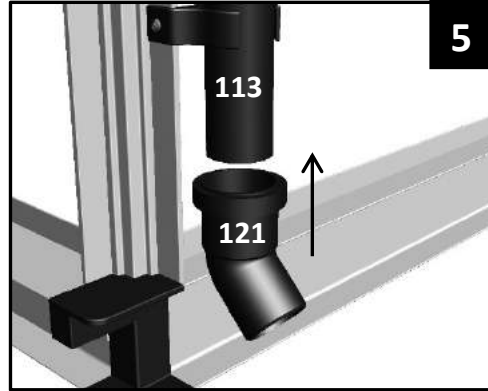
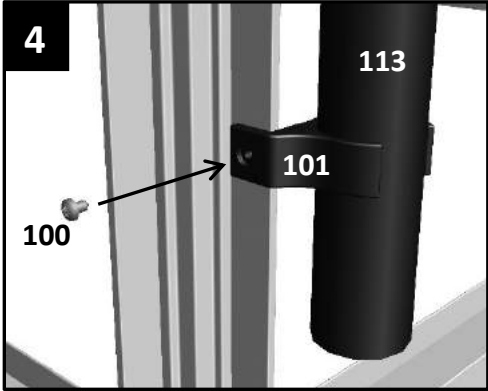

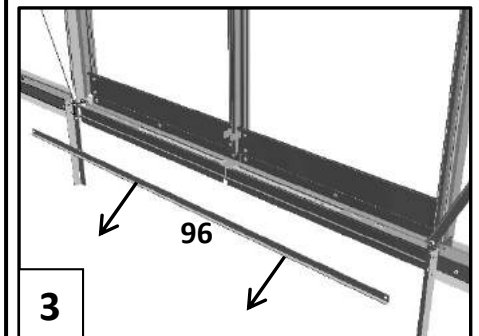
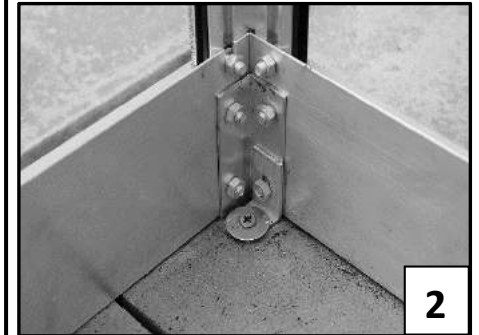
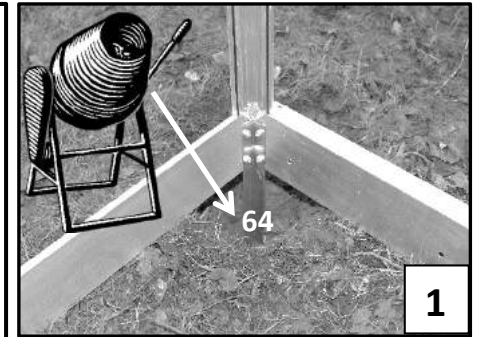
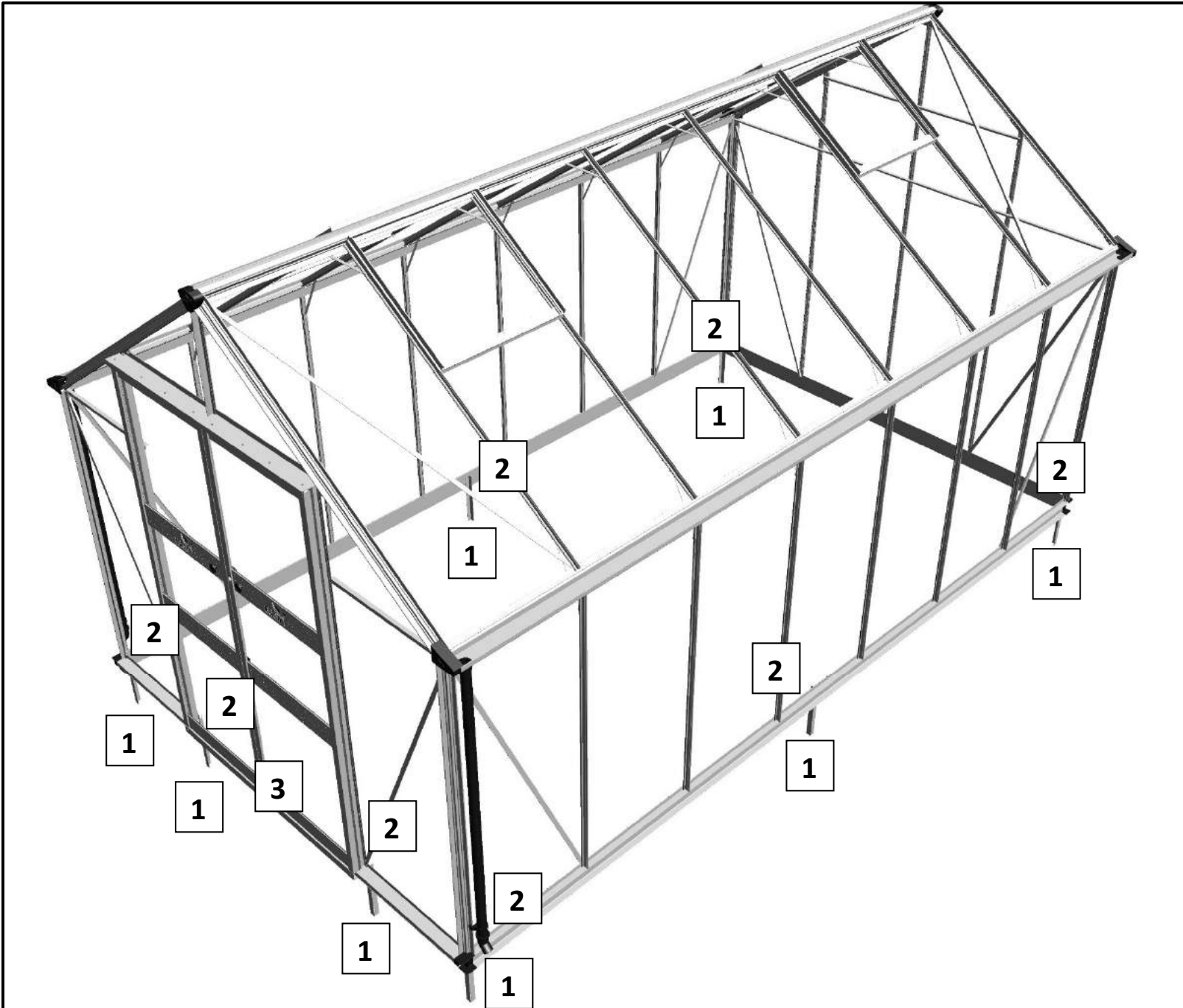

12 YEAR WARRANTY

Eden Halls Greenhouses Ltd. hereby agrees (subject to satisfaction of the Conditions referred to below) to make good free of charge by replacement or repair (at our election) any defects which we shall discover upon examination to be due to be faulty materials, components or workmanship which may appear in our greenhouse kits within 12 years of the date of despatch from our factory.

CONDITIONS OF WARRANTY CLAIM

(Each of which must be fulfilled before any warranty claim shall arise.)

1. That the claim is not attributable to any fault or damage arising from impact, modification, inappropriate use or treatment, incorrect handling or exposure to corrosive conditions, or the greenhouse being kept or installed other than under normal conditions, or to war, or act of God.
2. That the greenhouse must not have been repaired or serviced by any other than a qualified person employed by us.
3. That our instructions as to the assembly and the use of the greenhouse and its base have been strictly complied with.
4. That the claim is made by you as the original customer for your benefit.
5. That the detailed claim is notified to us in writing within 30 days of the date of discovery thereof.

GENERAL CONDITIONS OF WARRANTY

1. This warranty does not cover the cost of labour for the removal and replacement of any parts or parts replaced free of charge; such costs being the liability of the customer.
2. This warranty is only applicable to the greenhouse aluminium framework and ancillary parts forming the kit despatched and specifically excludes glass breakage.
3. This warranty is personal to you and is incapable of transfer and/or assignment.
4. This warranty does not extend beyond the cost of any faulty component referred to above.
5. This warranty applies in the United Kingdom only.

**Eden Halls Greenhouses Ltd
The Distribution Centre
Stoke Orchard
Nr. Cheltenham, Glos.
GL52 7RS**