

Charlton Fitting Instructions

Place the floor on to a solid level base.

Before assembly starts, cut out A and B on both side panels as shown.

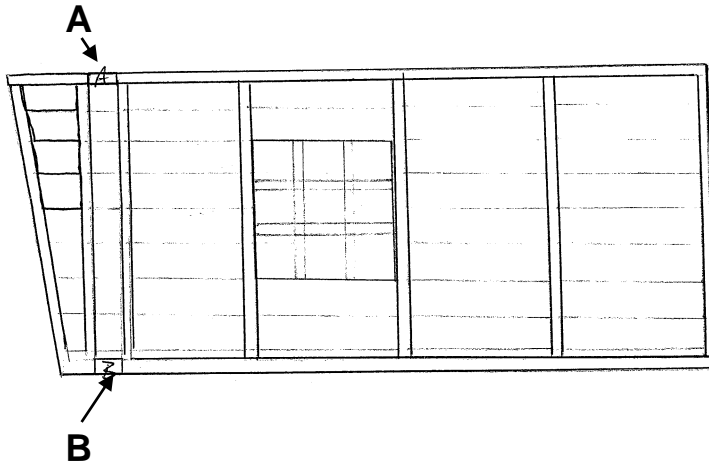

The panels are joined to each other through pre-drilled holes, using 80mm coach screws. It is usual to start with a side and back panel, then to add the other side panel. The action of tightening the screws draws the wall panels together.

The door panel now slides into the slots you previously cut out on the side panels. It is screwed from the inside using 60mm screws.

The wall panels are secured to the floor joists using 60mm screws. If nails, knock them in at an angle (skew nailing).

Once the walls are erected, fit the roof. The panel or panels are usually fixed to the walls with 40mm screws. Line up the roof flush with the back gable so it leaves a 300mm overhang at the front.

On the inside of your buildings there are roof spars that meet in the middle, fix these together using the triangle shaped roof ties using 4no. 40mm latt nails. This will help secure the roof and stop it from sagging.

Cover the roof panels with strips of felt, overlapping approximately 150mm. These are always fixed from the lowest part of the roof, working upwards. This ensures that rainwater running down the roof does not seep under overlapping edges. Clout nails are used to secure the felt.

Place the corner latts provided in the kit bag on all four corners of the building to cover the end grain of the timber (please note, these may be slightly longer and need trimming), then place the fascia's on the outer side of the roof (covering the end piece of felt) with the 40mm latt nails provided, locate the diamond into place (usually centre above the door) once the fascia's are on.

Assembling Bay Window:

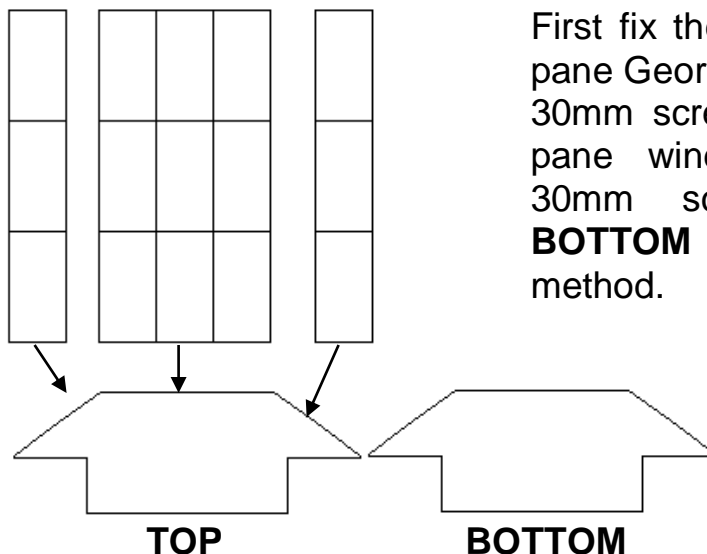

First fix the **TOP** section to the 9 pane Georgian window using 30mm screws. Then fix the x2 3 pane windows as shown with 30mm screws. Now fit the **BOTTOM** section using same method.

Finally glaze all the windows from the inside, and fix securely with the window latts provided. Once done run a line of silicone sealant (not supplied) around each window on the outside to stop any leaks from occurring.

Please note: We suggest the building is treated within one month of installation and every year thereafter, the floor should be well ventilated from underneath, also in time the roofing felt may need replacing, doing all this should prolong the life of the building.