



Assembly and Operating Instructions

# 1500 SERIES

**BUILT IN**

BDB1530GAE, BDB1540GAE & BDB1550GAE



**FOR OUTDOOR USE ONLY**

BMAN\_1500Series\_BuiltIn\_EU\_Apr20



EUROPE

Dear customer,

Congratulations and thank you for choosing our barbecue. We are sure you will find it a pleasure to use. Before you use the barbecue, we recommend that you read through the relevant sections of this manual, which provide a description of your appliance and its functions.

To avoid the risks that are always present when you use an appliance, it is important that the appliance is installed correctly and that you read the safety instructions carefully to avoid misuse and hazards.

We recommend that you keep this instruction booklet for future reference and pass it on to any future owners.

After unpacking the appliance, please check it is not damaged. If in doubt, do not use the appliance but contact your local customer care centre.

This appliance complies with requirements of EN 498:2012 & EN484:2019.

### Conditions of use

**These important notes apply to your appliance, failure to adhere to these conditions of use may affect your ability to make a claim under the manufacture's warranty.**

- This appliance must be serviced only by a qualified licenced person.
- This product is intended for personal, domestic or household use only, not commercial use.
- This product is intended for outdoor use only.
- This product must be installed, operated and maintained as per the instructions.
- Ventilation holes in the unit must not be obscured by the installation.

**Please ensure you read the instruction manual fully before you call for service, or a full service fee could be applicable.**

Record model and serial number here:

Model number: .....

Serial number:.....

PNC:.....

Important safety instructions.....3

Product description.....8

Product dimensions .....9

Gas specifications.....10

Installation warnings.....11

Mounting enclosure guideline .....12

Assembling the barbecue ..... 13

Burner removal and fitting and leak test procedure.....17

Operating instructions .....18

Cooking methods.....19

Cleaning and care.....21

Technical information.....22

Troubleshooting .....24

Notes.....25

Warranty .....27

Please read the user manual carefully and store in a handy place for later reference.

The symbols you will see in this booklet have these meanings:



### WARNING

This symbol indicates information concerning your personal safety.



### CAUTION

This symbol indicates information on how to avoid damaging the appliance.



### IMPORTANT

This symbol indicates tips and information about use of the appliance.



### ENVIRONMENT

This symbol indicates tips and information about economical and ecological use of the appliance.

### IMPORTANT INFORMATION THAT MAY IMPACT YOUR MANUFACTURER'S WARRANTY

Adherence to the directions for use in this manual is extremely important for health and safety. Failure to strictly adhere to the requirements in this manual may result in personal injury, property damage and affect your ability to make a claim under the BeefEater manufacturer's warranty provided with your product. Products must be used, installed and operated in accordance with this manual. You may not be able to claim on the BeefEater manufacturer's warranty in the event that your product fault is due to failure to adhere this manual.

Please read the user manual carefully and store in a handy place for later reference.



## IMPORTANT

### Important – check for any damages or marks

If you find the barbecue is damaged or marked, you must report it within 7 days if you wish to claim for damage/marks under the manufacturer's warranty. This does not affect your statutory rights.



## ENVIRONMENT

### Information on disposal for users

- Most of the packing materials are recyclable. Please dispose of those materials through your local recycling depot or by placing them in appropriate collection containers.
- If you wish to discard this product, please contact your local authorities and ask for the correct method of disposal.



## WARNING

This appliance must be serviced only by a qualified licensed person.

Improper installation, adjustment, alteration or maintenance can cause injury or property damage and may affect your ability to claim under the manufacturer's warranty.

Please contact your nearest BeefEater Service Department for additional information or assistance for an approved installer.

### Note to the installer

This manual must remain with the owner for future reference.



## WARNING

- Accessible parts may be very hot. Keep young children away.
- Read instructions before using the appliance
- Do not move the appliance during use
- Turn off the gas supply at the cylinder after use.
- Use protective gloves when handling particularly hot components.
- Do not lean over barbecue when lighting.
- Do not leave the barbecue unattended when alight.
- Do not delay lighting once the gas has been turned on.
- Do not place articles on or against this appliance
- Do not spray aerosols in vicinity of this appliance while it is in operation.
- Do not use or store flammable materials in or near this appliance.
- Do not use caustic or abrasive based cleaners on the barbecue.

- Do not attempt to dismantle or adjust the control valves.
- Do not attempt to dismantle or adjust the regulator.
- Do not test for leaks with a naked flame.
- Do not modify this appliance.
- Do not obstruct any ventilation of the barbecue.
- Parts sealed by the manufacturer or his agent shall not be manipulated by the user.
- Check whether the venturis of burners are blocked before using the appliance.

Failure to adhere to the above warnings may cause injury or property damage and affect your ability to make a claim under the manufacturer's warranty.



## CAUTION

This appliance is set up for Universal LPG and is labelled accordingly. A natural gas conversion kit is available if required. Conversion of this unit to natural gas must be carried out by a qualified licensed person and a Certificate of Compliance must be issued to the owner at the completion of the installation and conversion.



## IMPORTANT

BeefEater Barbecues are approved for OUTDOOR USE ONLY and must not be used in a building, garage or any other enclosed area.

- BeefEater Barbecues must not be used inside recreational vehicles or boats.
- Read instructions thoroughly before operating this Barbecue.
- Save this manual for future reference.
- Always use the Barbecue on a flat, level surface.
- Some foods produce flammable fats and juices. Regular cleaning is essential.
- Attend an operating barbecue at all times. Damage caused by fat & grease fires is not covered by warranty.
- When not in use keep Barbecue dry and covered.



## WARNING

If you smell gas:

1. Shut off gas to the appliance.
2. Extinguish any open flame.
3. Open hood.
4. If odour continues, immediately call your gas supplier or your fire department.

For your safety

1. Do not store or use gasoline or other flammable vapours or liquids in the vicinity of this or any other appliance.
2. An LPG cylinder not connected for use shall not be stored in the vicinity of this or any other appliance.

# IMPORTANT SAFETY INSTRUCTIONS



## WARNING

**Failure to follow these instructions and observe the warnings provided in this operations manual could result in fire, explosion or burn hazard, which could cause property damage, personal injury or death.**

Gas vapour is highly explosive and can cause serious bodily injury or damage to property if allowed to accumulate in a confined space and ignited.

This appliance must not be installed under or on any combustible material. Minimum clearance from combustible materials to all sides of the appliance is 450mm (18").

These instructions must be left with the owner.

### NOTE:

1. Do not use gas other than the type specified on the Data Plate.
2. The appliance is designed for use by adults, keep children away from the barbecue at all times.
3. Use only on a flat, level, stable non-combustible surface. Do not use this appliance on any surface that can burn or melt.
4. When in use, gas cylinder should be kept at designated mountings of barbecue, and supply hoses kept away from any hot surfaces.
5. To prevent accidental fires, before using the appliance ensure that there is no apparent damage to hose and regulator and all joint connections are in good order and not leaking.
6. Use a soapy water solution on all joints in order to check for leaks. If bubbles appear, it indicates that there is a leak and the appliance must not be used.
7. LPG cylinder, regulator and hose must comply with national standards.
8. Do not move or attempt to move the appliance while in operation.
9. Do not operate this appliance before leak checking hoses and gas cylinder connection.

### To the installer

- For fixed installations, this appliance must be installed in accordance with local authority and any relevant statutory regulations.
- For fixed installations, refer to relevant statutory regulations for pipe sizing details.
- Consult other trades. Where required, consult a bricklayer or an electrician for parts of the installation that could have an effect on these areas.
- Allow a 20mm gap from back of barbecue body for ventilation and air access.
- Test appliance for correct operation before leaving, and instruct user on its use.
- If correct operation cannot be achieved, disconnect barbecue from gas supply, and contact your nearest BeefEater dealer.
- Please only use BeefEater supplied hose(s) to connect this appliance. Natural Gas conversion kits are available from your nearest BeefEater dealer.
- Australia only (applies to all gas types) : Where a mobile appliance is to be connected to a fixed gas supply via a flexible hose connection, a retaining tether of adequate strength shall be fixed to the appliance and be suitable to be fixed to the wall within 50mm of each connection point. The length of the tether shall not exceed 80% of the length of the hose assembly. In this way, if the barbecue is accidentally moved, the tether stops the barbecue from stretching the hose.

### Do not

- Lean over barbecue when lighting.
- Leave cooking food unattended.
- Delay lighting burners after turning gas on.
- Spray or store aerosols in vicinity of barbecue whilst in operation.
- Place articles on or against this appliance
- Store combustible materials, gasoline or flammable liquids or vapours within 450mm (18") of barbecue.
- Use caustic based cleaning agents on the barbecue.
- Operate barbecue with any cover on.
- Use plastic or glass utensils on the barbecue.
- Operate barbecue in strong winds.
- Attempt to dismantle control valves.
- Attempt to dismantle or adjust regulator.
- Test for gas leaks with a naked flame.
- Store gas cylinder indoors, or in any enclosed area.
- Lay the gas cylinder down. Always keep it upright.
- Use barbecue indoors.
- Expose hose to direct sunlight.
- Modify the construction of this appliance or the size of any burner or valve orifice.

- Move the appliance during use.
- Obstruct any ventilation of barbecue or the cylinder.
- Allow the flexible gas supply hose or any electrical cord to come in contact with hot surface of the appliance.
- Allow children to operate this appliance.
- Use charcoal or any other solid fuel in this appliance.
- Disconnect any gas fittings while the appliance is operating.
- Use a rusty or dented gas cylinder or cylinder with a damaged gas valve.
- Fill the gas cylinder beyond 80% capacity.
- Touch some accessible parts, other than the ones meant for handling. They may be hot.

## Do

- Spanner tighten all gas fittings as per instructions.
- Check all gas hoses and line connections for damage, cuts or cracks each time the appliance is about to be used.
- Always leak test with a solution of soapy water.
- Check main opening, throat and venturi to each burner and pilot flame tube regularly for insect nests (eg. wasp, ants or spiders). Nests are dangerous and must be cleaned out thoroughly.
- Visually check burner flames to confirm lighting.
- Use your barbecue only on a level surface.
- Attend barbecue whilst cooking food.
- Preheat the barbecue for up to 10 minutes.
- After cooking turn barbecue to high for up to 10 minutes to burn off excess grease.
- Let the barbecue cool before replacing any lid or cover.
- Regularly replace foil material in grease/drip tray.
- Keep children away from barbecue at all times.
- Have the gas cylinder filled by an authorised LPG supplier.
- Refer to this instruction manual if in doubt concerning assembly, installation, or operation.
- Use protective gloves when handling hot components.
- Close the gas cylinder valve after each use.
- Clean the grease/drip tray regularly and clean the appliance at least twice annually.
- Always remove any lid or cover off the appliance before lighting.
- Carefully follow the instructions relating to the hose/regulator connection.
- Keep the barbecue area free from combustible materials, gasoline, flammable liquids or vapours.

## IMPORTANT

**Should the appliance go out for any reason, turn off all control knobs and the cylinder gas valve. Wait 5 minutes before attempting to relight the appliance.**

- If a grease or fat fire should occur, immediately turn off all control knobs and the gas cylinder valve until the fire is out. Remove all food from the appliance.
- A leak test must be carried out prior to using the appliance for the first time and whenever the gas cylinder is refilled or whenever the gas hose and regulator have been disconnected from the gas cylinder or appliance.

# GAS CYLINDER SAFETY INFORMATION

Gas cylinders must be stored outdoors, out of reach of children and must not be stored in a building, garage or any other enclosed area.

- This appliance is designed to be used with a gas cylinder not exceeding 9kg (20lbs) capacity. The overall size of the gas bottle should not exceed 315mm in diameter and 460mm in height.
- The Gas cylinder must be constructed and marked in accordance with specifications for LP Gas Cylinders.
- Ensure gas cylinder is within the expiration date, it is not advised to use or attempt to refill a gas cylinder that is outside of its expiration date.
- The gas cylinder supply valve must be turned off when the appliance is not in use.
- The gas cylinder used must incorporate a safety collar to protect the valve assembly.
- The gas cylinder must always be kept and used in the upright position.



## IMPORTANT

**When disconnecting and removing the gas cylinder for the purpose of refilling, always observe the following procedure:**

- Ensure that all gas control valves on the appliance and the gas cylinder are turned off before disconnecting the gas line from the cylinder.
- Do not smoke or use a naked flame near the appliance or gas cylinder while disconnecting the gas line between the appliance and gas cylinder.
- Remove the gas cylinder from the enclosure before disconnecting the gas line from the appliance.
- Tighten all connections before placing the gas cylinder back in its enclosure.

The Gas Leak Testing Procedure should be conducted every time the gas cylinder is refilled and reconnected to the appliance – before using the appliance.

### Regulator Connection

1. Check that all control knobs are in the 'Off' position.
2. Make sure the cylinder valve is off by turning the valve knob all the way clockwise.
3. Remove the protective cap from the cylinder if present.
4. Make connection as described in figures 1 and 2.
5. Leak-test the connection with a soapy water solution. (See Gas Leak Testing Procedure).

Hose and regulator replacement must be a genuine part specified for this appliance and is obtainable from your nearest BeefEater stockist.

FIG 1

### Standard regulator

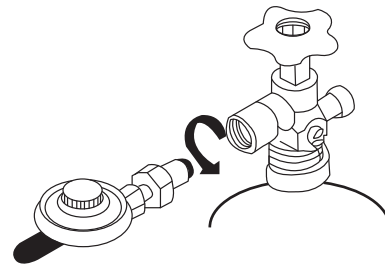
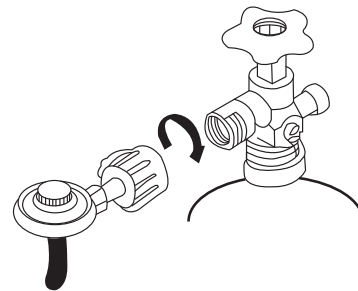

FIG 2

### Quick connect regulator



### Gas Leak Test Procedure

Use the following procedure to check for gas leaks. Never use a naked flame to check for gas leaks.

1. In a small container, mix up a solution of water and detergent or soap. Mix the solution well.
2. Make sure that the gas supply valve on the gas cylinder is turned on.
3. Make sure that the gas control valves on the appliance are all turned off.
4. Using a brush or spray bottle apply the solution to the gas line and each join in the gas line.
5. Bubbling of the solution will indicate that there is a leak present.
6. Re-tighten or re-seal any joints that are leaking.
7. If a leak persists then contact your distributor or the manufacturer for assistance.

## LPG safety information

- Use only gas cylinders, which meet national and regional codes. The minimum cylinder size for this barbecue is 6kg. Ensure that the cylinder can provide enough fuel to operate the appliance. If in doubt, check with your local gas supplier.
- Pay attention that when changing the gas cylinder which shall be carried our away from any source of ignition.
- Never connect a cylinder, which does not meet local codes.
- All cylinders 7kg or larger that do not sit in the location provided inside the trolley must be placed on the ground at the rear of the barbecue.
- Cylinders smaller than 7Kg (maximum size 465mm high x 306mm wide) may be placed on the hook on the right side of the barbecue.
- The isolation valve must be turned off when the appliance is not in use.
- Gas cylinders must be stored in an approved housing out of reach of children.
- When disconnecting the gas bottle ensure that all the control valves are in the 'OFF' position.
- When reconnecting the hose to the bottle, ensure that all connections are tight before replacing in storage compartment.
- Carry out a leakage check as detailed below after each reconnection.
- Only regulator which complies with EN 16129 can be used.
- The length of hose cannot exceed 1.5m. In Finland, the length of hose cannot exceed 1.2m.
- It's necessary to change the flexible tube when the national conditions require it, and/or depending on its validity.
- Make sure that the flexible tube is not subjected to twisting when the appliance is in operation.

# PRODUCT DESCRIPTION

## 4 burner built-in barbecue

- ① Warming rack
- ② Cast iron grill
- ③ Cast iron hotplate
- ④ Vaporisers
- ⑤ Burners
- ⑥ Roasting hood
- ⑦ Thermometer
- ⑧ Burner box
- ⑨ Support bracket and fasteners (purchase kit BAH70HS separately, needed for installation in BeefEater outdoor kitchen)
- ⑩ Control panel
- ⑪ Flip down control panel cover
- ⑫ LPG hose and regulator
- ⑬ Grease tray

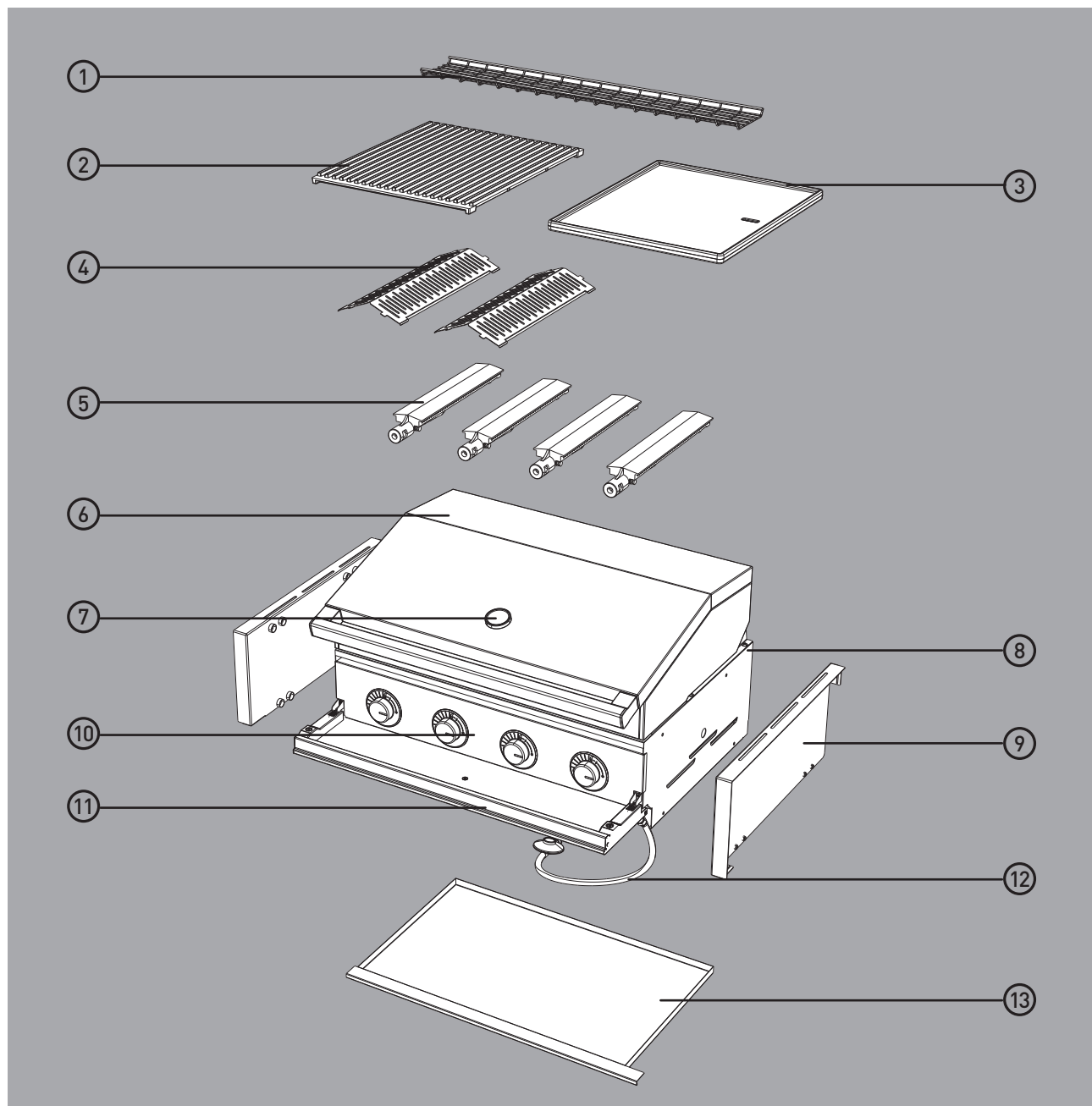



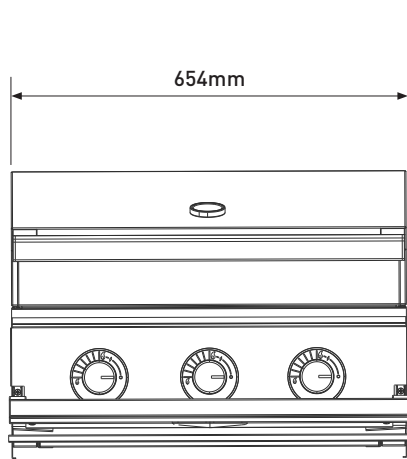

3 burner

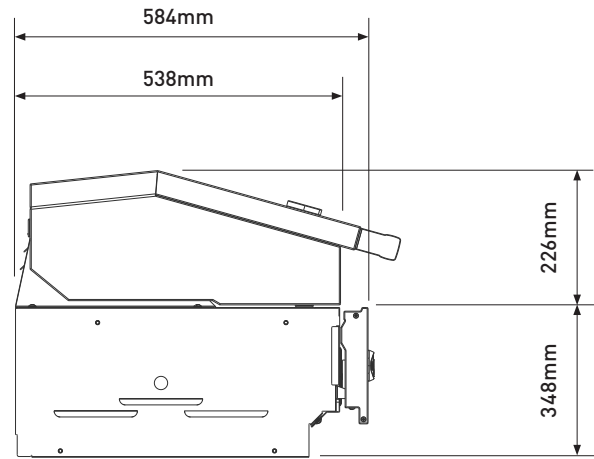

Hood and flip down control panel cover closed

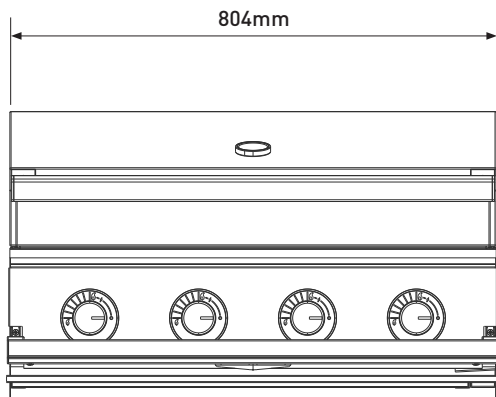

4 burner

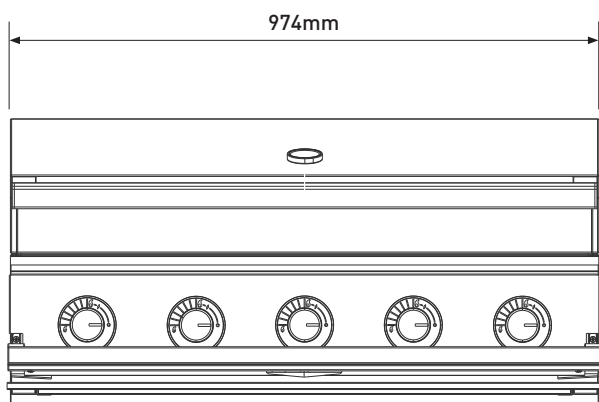

5 burner

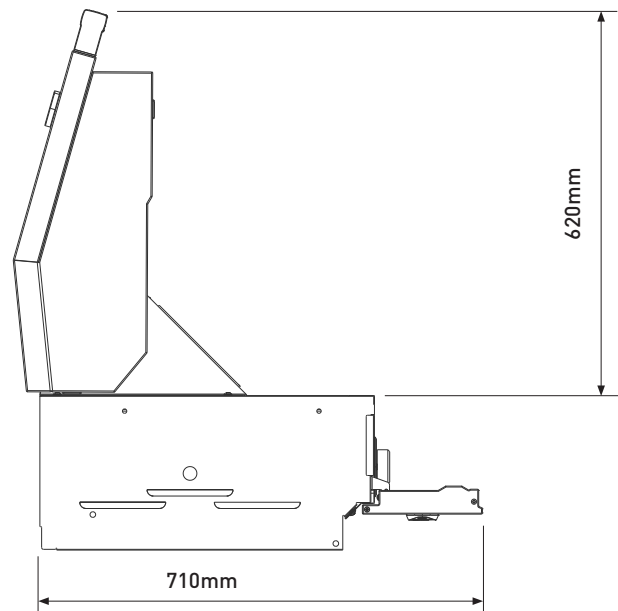

Hood and flip down control panel cover open

# GAS SPECIFICATIONS

## NOTES:

- This appliance **MUST** be installed and serviced only by a qualified licensed person.
- This product is intended for outdoor use only.

### Connecting the appliance to an LPG gas supply

This barbecue is set up for LPG gas and is labelled accordingly.

The appliance may be supplied LPG from either

- A 9kg portable cylinder, or
- A remote supply of via fixed pipe work.

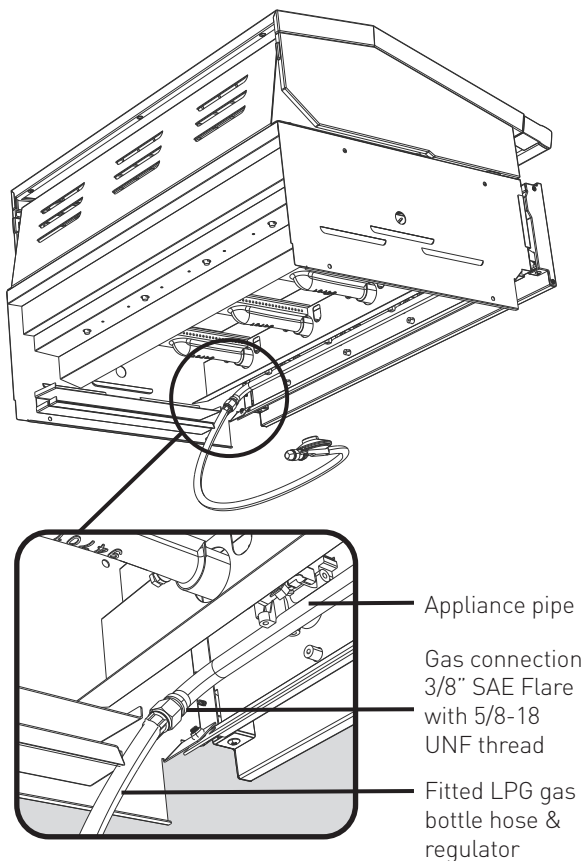

### Connecting the appliance to a LPG gas cylinder

- The appliance has a 9kg gas bottle regulator and hose already fitted.
- Connect the fitting of the inlet of the regulator to the valve on the LPG cylinder.
- Carry out a leakage check.

### Gas bottle safety information

- This appliance, when connected directly to an LPG cylinder, the cylinder capacity shall be 9kg(20lbs).
- The gas cylinder must be made and marked in accordance with specifications for LPG cylinders.
- It is recommended to turn off the cylinder valve when the appliance is not in use.
- Gas cylinders must be stored in an approved housing out of reach of children.
- When disconnecting the gas bottle ensure that all the control valves are in the 'OFF' position.
- Remove the bottle from any housing in which it may be stored before disconnection.
- When reconnecting the hose to the bottle, ensure that all connections are tight before replacing in the storage compartment.
- Carry out a leakage check. (See leak test procedure on page 13).

### Connecting to a remote supply of LPG

- The appliance shall be installed in accordance with local authority and any relevant statutory regulations.
- Remove the gas bottle hose and regulator from the appliance pipe.
- Connect the consumer supplied fixed LPG pipework to the appliance pipe.
- Carry out a leakage check on all connections.

**! WARNING**

- This appliance shall only be used in an above ground, open air situation with natural ventilation without stagnant areas, where gas leakage and products of combustion are rapidly dispersed by wind or natural convection. This barbecue has been designed for outdoor use only. Failure to adhere to these installation instructions may cause injury or property damage and affect your ability to make a claim under the manufacturer's warranty. Refer to diagrams below.
- Never install this barbecue inside any building, garage, shed or breezeway or inside a boat, caravan or recreational vehicle. This is to prevent the possibility of fire or carbon monoxide poisoning or asphyxiation.
- Any enclosure in which this appliance is installed shall comply with one of the following:
  - An enclosure with walls on all sides, but at least one permanent opening at the ground level and no overhead covering
  - Within a partial enclosure that includes an overhead cover and no more than 2 walls
  - Within a partial enclosure that includes an overhead cover and more than 2 walls, the following shall apply:
    - At least 25% of the total wall area is completely open and at least 30% of the remaining wall area is open and unrestricted
- In the case of balconies, at least 20% of the total of the side, back and front wall areas shall be and remain open and unrestricted.

### Choosing a location

When planning the location and preparing the installation structure for this appliance note the following:

- This appliance must be installed in accordance with with local authority and any relevant statutory regulations.
- Requirements in these instructions for clearances to combustible materials also apply to combustible materials that have non-combustible materials attached to their surface.
- The minimum clearance from combustible construction materials to all sides of the appliance is 450mm.
- The minimum clearance to a vertical wall above bench level that is made from combustible material is 450mm.
- The vertical clearance above the cooking surface to any combustible materials must be at least 1000mm.
- When using LPG in an enclosure ventilation must be provided. Gas is highly explosive and can cause serious injury and damage to property if allowed to accumulate and then be ignited.
- Avoid windy positions as this will affect cooking performance and burner efficiency. If this situation cannot be avoided some shielding may be necessary.

### Natural gas requirements

- The enclosure must be constructed so that access can be gained to the natural gas regulator at all times.

### Natural gas conversions

**! WARNING**

Conversion of this unit to natural gas must be carried out by a qualified licensed person and a Certificate of Compliance must be issued to the owner on completion of the installation and conversion. Conversion of this barbecue by unlicensed persons may result in improper functioning of the appliance, injury, property damage and may affect your ability to make a claim under the manufacturer's warranty.

Outdoor area example 1

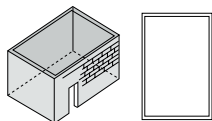

Outdoor area example 2

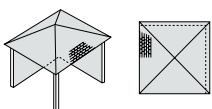

Outdoor area example 3

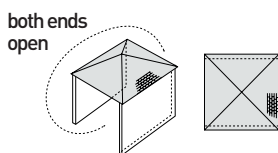

Outdoor area example 4

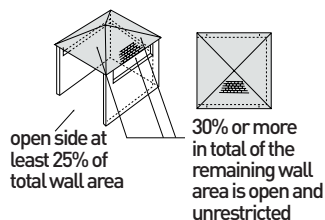

Outdoor area example 5

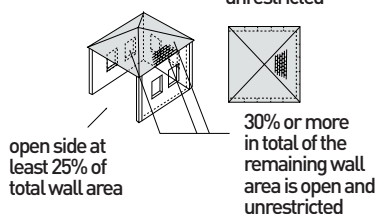

# MOUNTING ENCLOSURE GUIDELINES

## Mounting enclosure dimensions when installed with Beefeater hanging bracket BA70HS

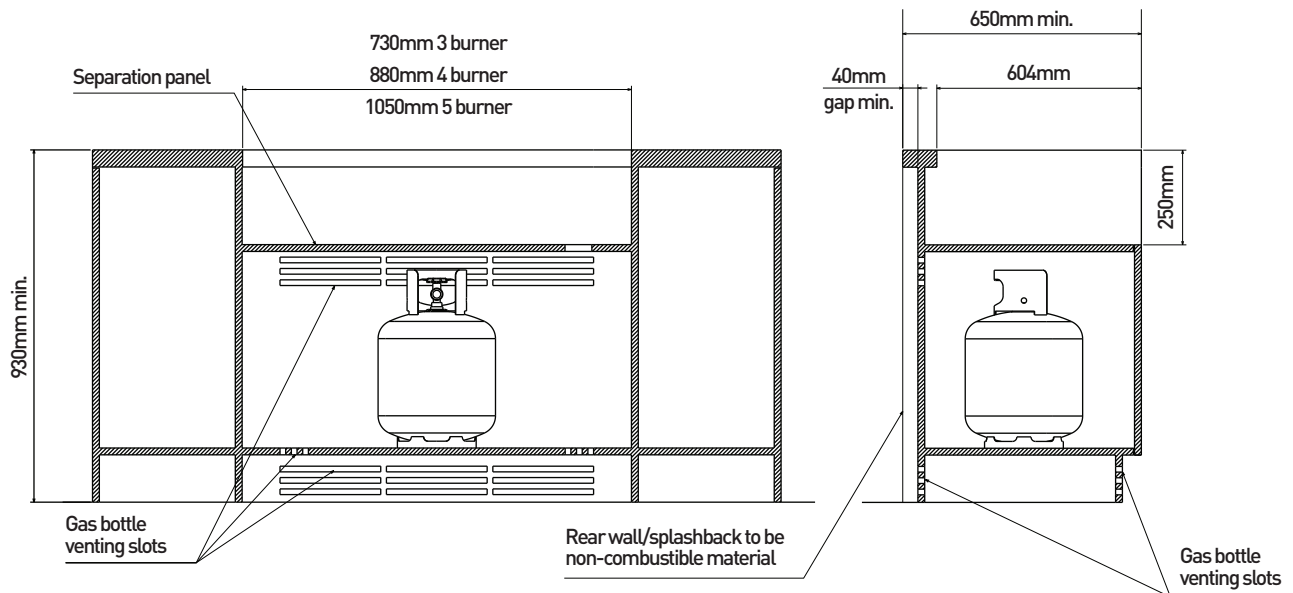

### Enclosure construction

- All materials used for the construction of the enclosure and gas bottle compartment must be non-combustible.
- A 40mm min. gap between the enclosure and rear wall is required. This allows for venting of the gas bottle compartment. Vents should also be positioned at the front of the enclosure.
- The cutout size specified above and below allow for a 20mm gap between the back of the barbeque and benchtop. This gap will help maintain air flow around the barbeque.
- The cutout sizes specified above are for use with the Beefeater hanging bracket BA70HS. This bracket is purchased separately as an accessory.
- The cutout sizes specified below are for when the product is installed without hanging brackets. The product rests directly onto its base.

### Enclosure ventilation requirements

AS5601 ventilation requirements for 9kg cylinder storage are:

- Where of sheet metal or similar impervious construction there shall be ventilation openings at the top and bottom of the enclosure or recess, each opening providing a free area of at least 200cm<sup>2</sup> for every cylinder enclosed.
- For LPG installations having enclosed cabinetry below the separation panel that does not contain a gas bottle, low level venting must be installed. This is to allow the gas which is heavier than air to escape from the enclosure in the situation where there may be a leak. A minimum opening of 200cm<sup>2</sup> is required.

### Gas bottle size

- This appliance is designed to be used with a gas cylinder not exceeding 9kg (20lbs) capacity. The overall size of the gas bottle should not exceed 315mm in diameter and 460mm in height.

## Mounting enclosure dimensions when installed without hanging brackets

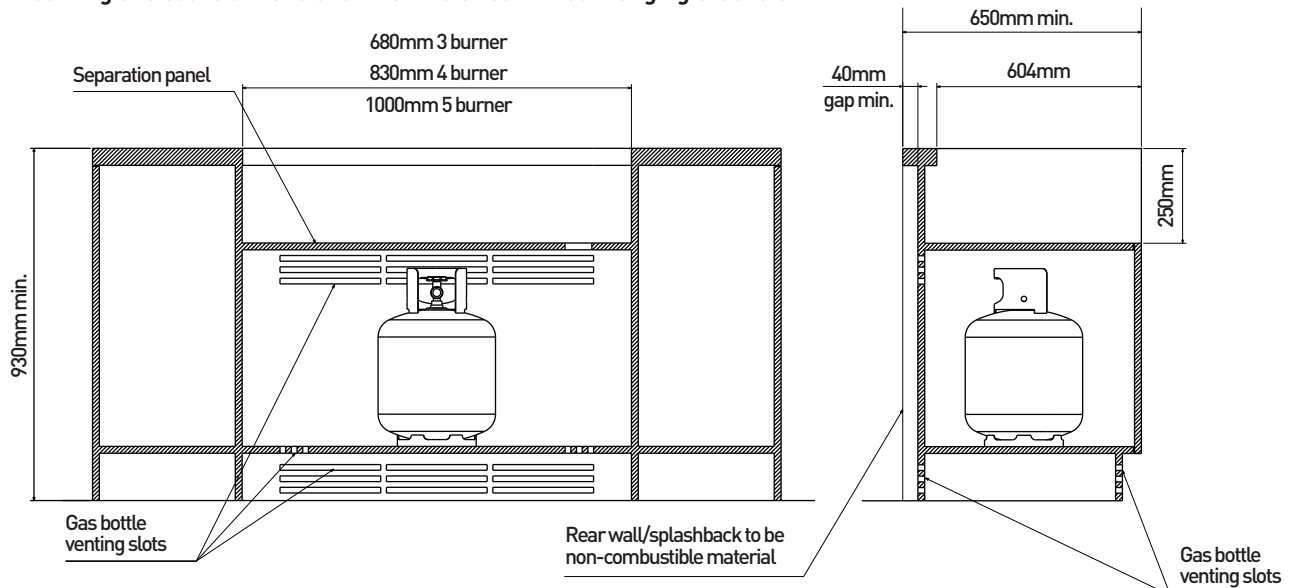

Tools required:

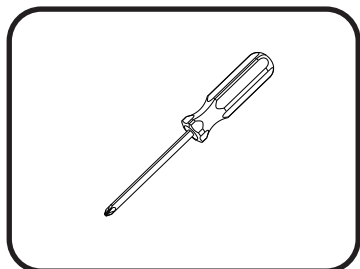

Fasteners supplied (with hanging bracket kit)



The barbecue can be mounted into the enclosure by using the BeefEater hanging bracket kit BA70HS or by resting the barbecue directly on its base. See step 1-4 for mounting of the hanging bracket kit.

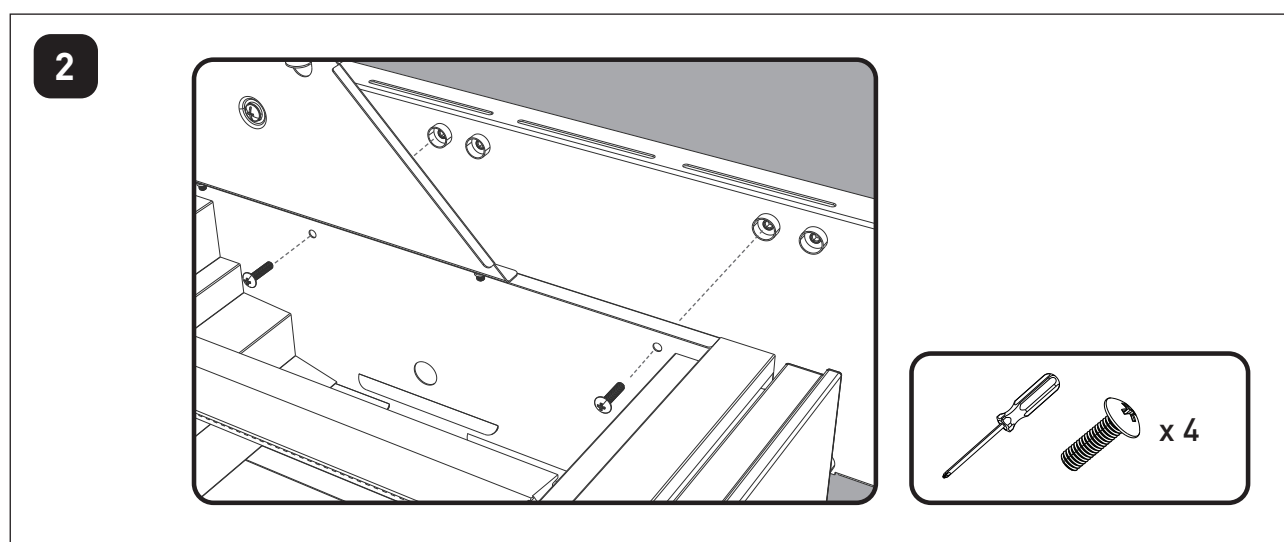
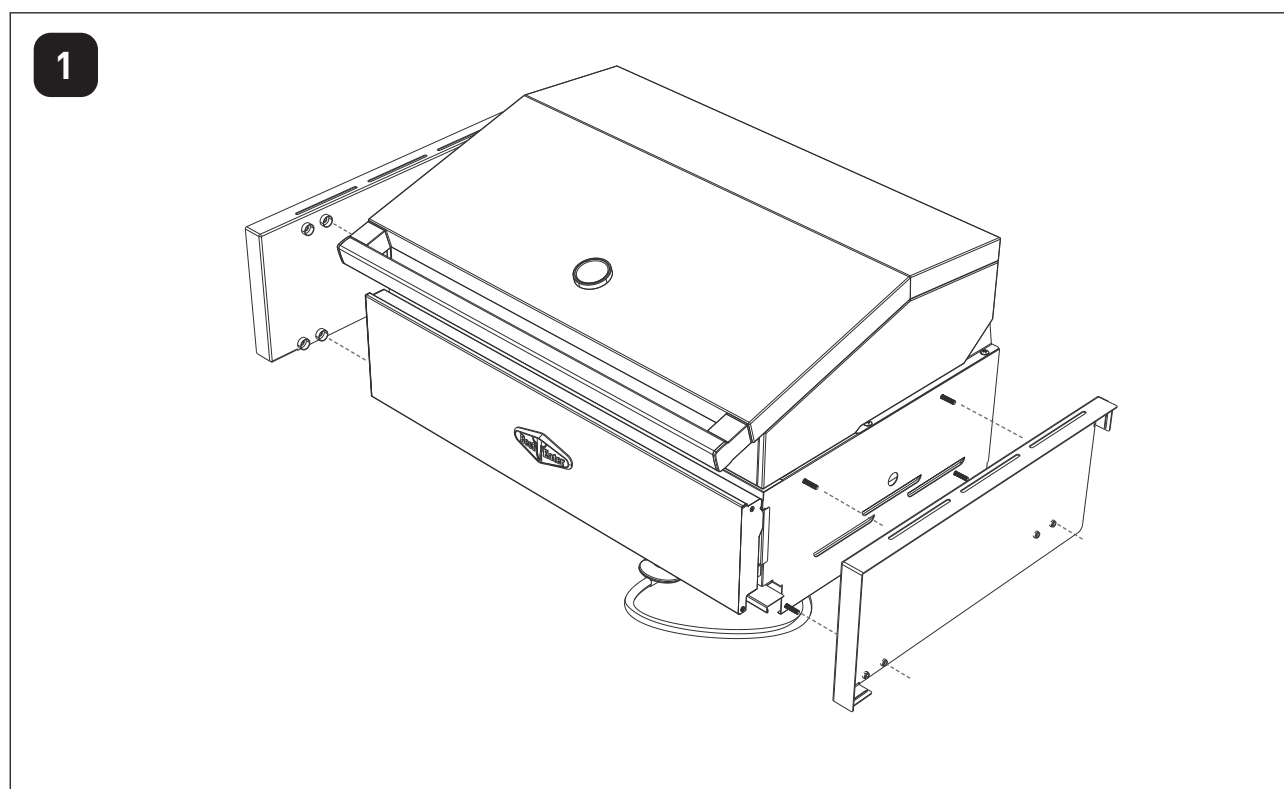

# ASSEMBLING THE BARBECUE

3

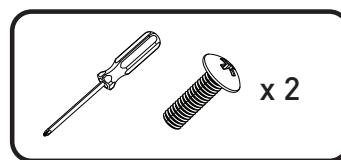
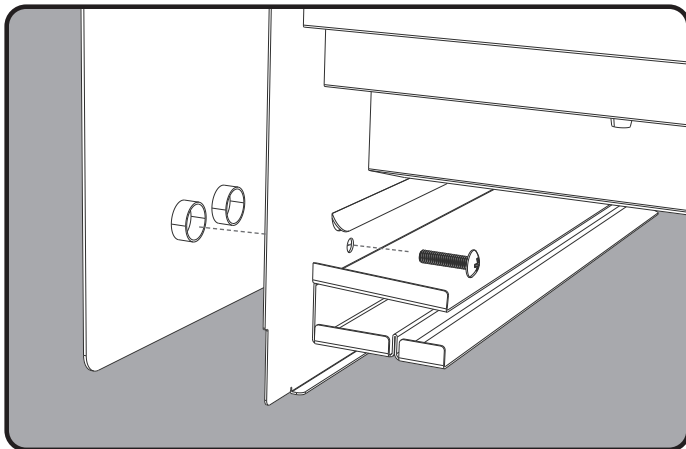

4

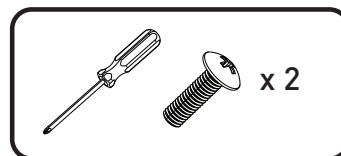
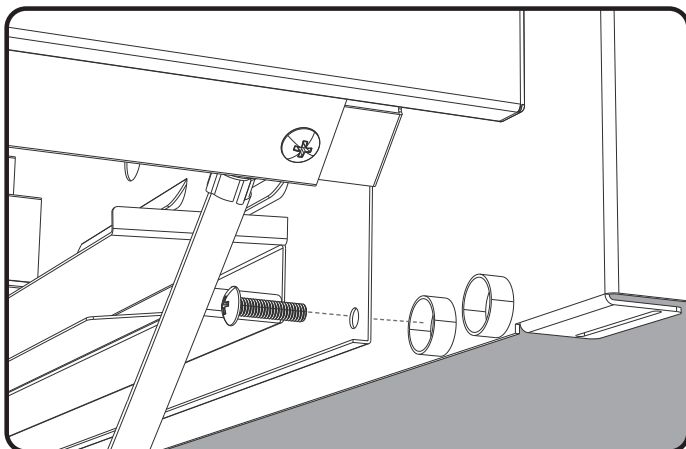

5

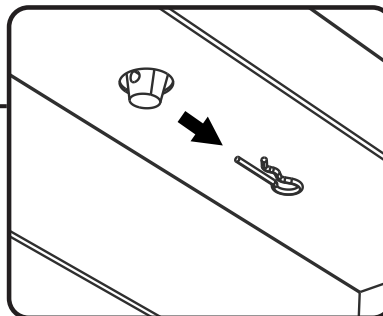
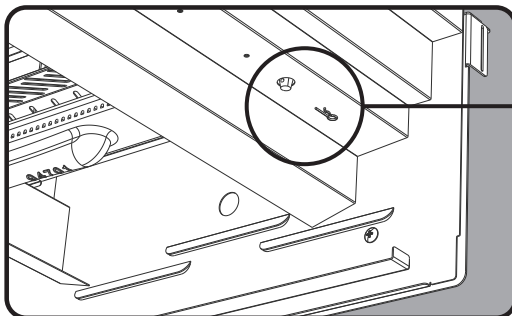

6

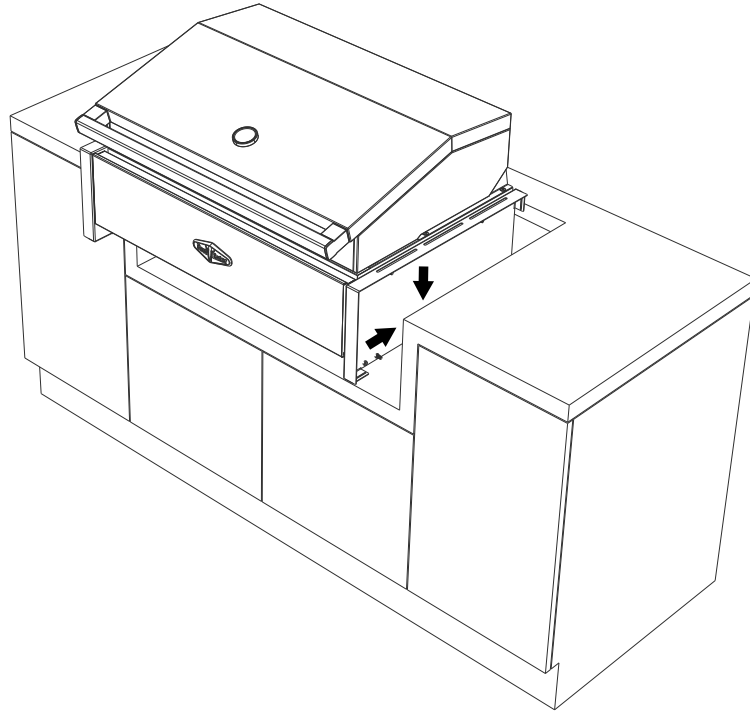

7

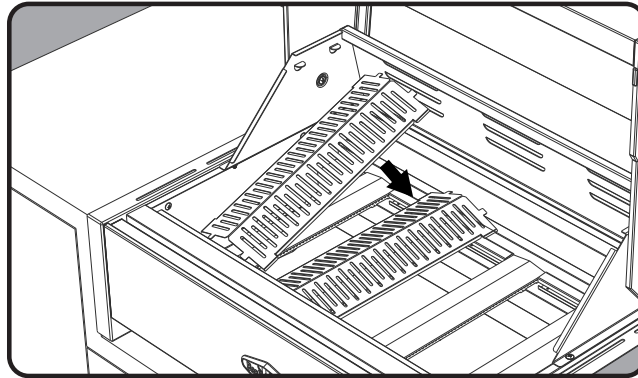

8

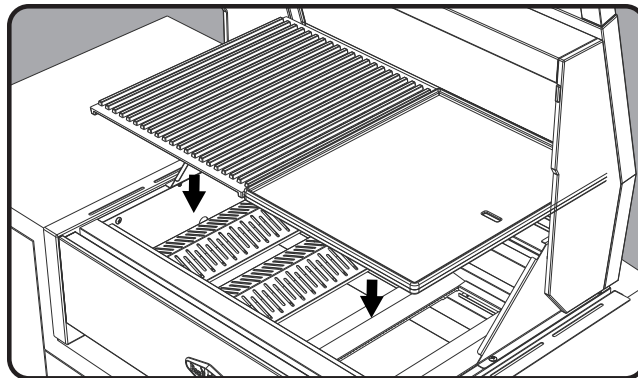

## ASSEMBLING THE BARBECUE

9

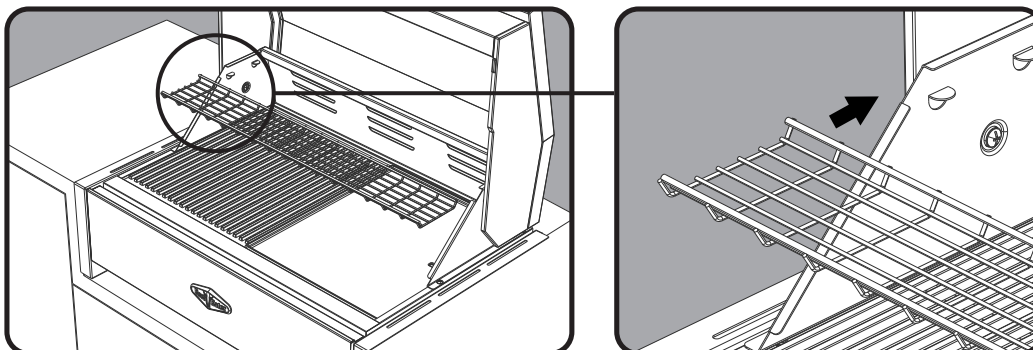

10

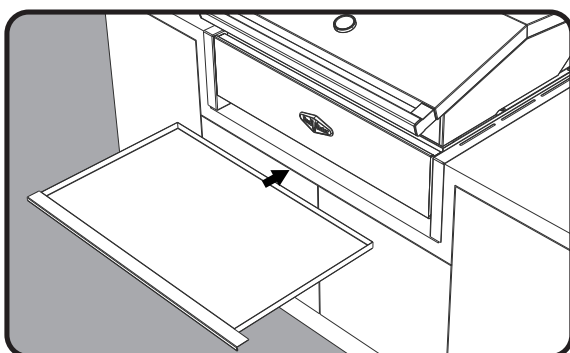



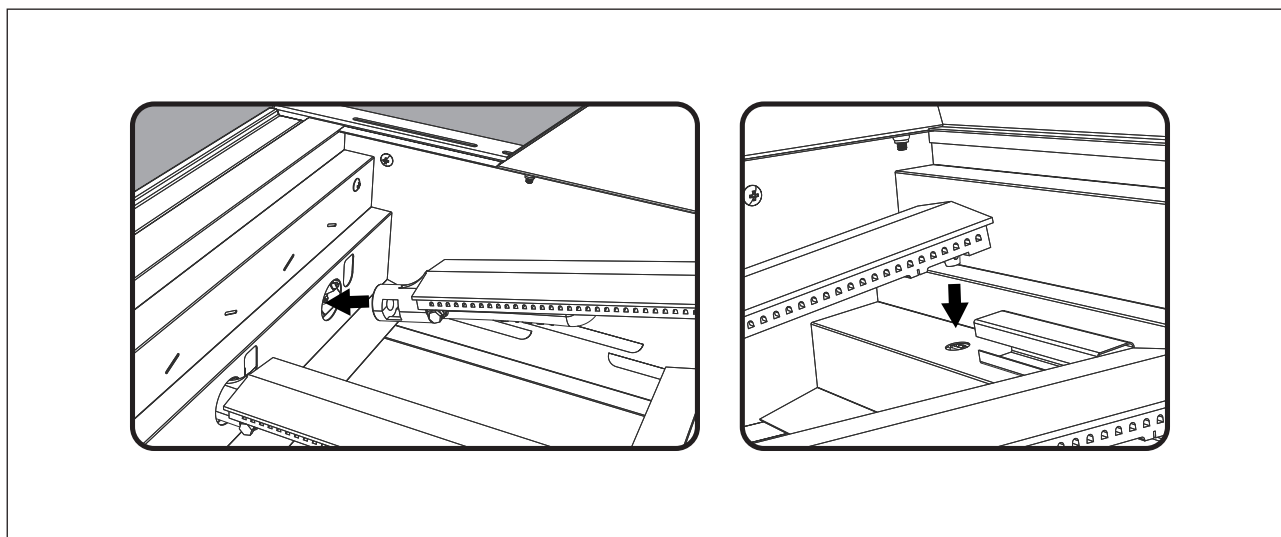

**! IMPORTANT**

After completing the gas hose connections, conduct a leak test following the leak test procedure before using the appliance.

**! WARNING**

To ensure gas tight connections, complete the gas leak test procedure before and after gas hose connection and after every reconnection of the gas cylinder. Failure to do so may result in a fire or explosion.

**Leak test procedure**

- Ensure all gas valves are in the 'OFF' position.
- In a small container, mix a solution of water and detergent or soap.
- After connection of the hose, turn on the gas supply at the gas bottle.
- Using a brush apply the solution to all gas connection points and look for bubbles forming.
- Bubbling will indicate a leak.
- Turn off the gas supply and re-tighten the joint. Repeat the leak test.
- If the leak persists, turn off the gas at the bottle and contact a licensed gas fitter to correct.

# OPERATING INSTRUCTIONS

## Control functions

Before lighting the barbecue:

- Check that all hoses and gas fittings are tight
- Open the roasting hood
- Check all control knobs are in the 'OFF' position
- Ensure that the cooking surfaces are clean
- Turn the gas isolation valve 'ON'

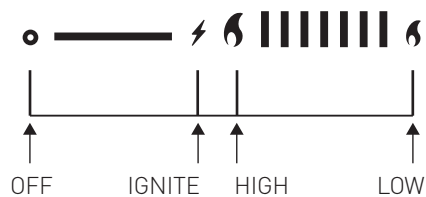
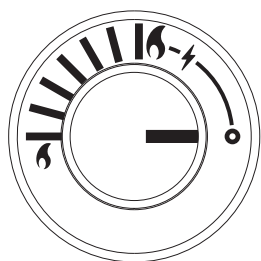

## Lighting instructions

- Do not attempt to light burners with the cooking surfaces covered
- Read instructions before lighting
- To light a burner, depress the knob and rotate to ⚡. The starter mechanism will click and the burner will light
- If burner did not light, depress knob and turn back to the 'OFF' position
- Allow several minutes for gas to disperse then repeat lighting procedure
- Once ignited, the knob can then be turned to the desired heat setting. The knob does not need to be pushed in while selecting the heat setting

### **Direct cooking method**

This method of cooking can be done with the hood either closed or open.

Commonly used for traditional barbecuing. Place food over the lit grill section. Excess flaring may occur, so care must be taken while cooking. If direct cooking with the lid closed, always check inside the roasting hood regularly. The direct cooking method is recommended for steaks, chops, sausages, and hamburgers.

### **Indirect cooking method**

This method of cooking requires the hood to be closed.

Indirect cooking involves little or no heat directly underneath the food. Instead, the food is placed on the grill, the burners below the food are turned off or Low, and burners on either side are used. The hood is closed to trap heat and moisture. With this method, heat circulates around the food, cooking by convection. By trapping the vapour inside your "outdoor oven", the cooking vapour will fall back on the food on all sides, not just from underneath. The food cooks more evenly, and stays moist in the process.

Indirect cooking is similar to using a conventional oven and is recommended for rotisserie cooking, roasts, poultry, casseroles, vegetables and whole fish.

# INDIRECT COOKING / ROASTING

## Reposition the grill plates

To achieve the best heat circulation around the food, it is best to remove the hotplate from the barbecue and position the two grill plates in the centre. Reposition the vaporisers from above the 2 outside burners to above the inside burners. This will give unrestricted heat circulation from the 2 outside burners.

## Preheating your Barbecue

Like an oven, preheating your barbecue before cooking produces better results. Because your hood retains heat so efficiently, preheating your barbecue is quicker with the hood down.

Turn all burners to high. Close the hood, and allow to preheat for about 5 minutes. Then reduce the burner settings to achieve and maintain the required temperature, by following these guidelines.

## Maintain the right cooking temperature

### CAUTION

Do not exceed the temperature warning on the temperature gauge. Operating the barbecue above this temperature may cause damage to the appliance. Your hood is designed to keep the heat in, so requires constant monitoring.

These two charts tell you how hot and how long to cook various types of meat, and the approximate burner settings to help you achieve these results.

MODEL	BURNERS
Four burner	Two inside burners off Two outside burners to medium
Five burner	Three inside burners off One outside burner to high Other outside burner to medium

TYPE OF MEAT	COOKING TEMPERATURE	APPROXIMATE COOKING TIMES	
Beef	180°C/355°F	45–55min per kg	20–25min per lb
Lamb	180°C/355°F	45–55min per kg	20–25min per lb
Pork	170°C/340°F	55–60min per kg	25–30min per lb
Veal	160°C/320°F	40–50min per kg	18–23min per lb
Poultry	180°C/355°F	40–50min per kg	18–23min per lb
Seafood	150°C/300°F	20–30min per kg	9–15min per lb

You may find it useful to purchase a meat thermometer to help take the guess work out of cooking.

Meats such as beef, lamb, veal and pork should be about 70°C/160°F when medium. Chicken and turkey should be 85–90°C/185–195°F.

Most importantly, do not allow your barbecue to overheat. Your hood is designed to keep the heat in, and also requires constant monitoring.

Do not use more than 2 burners on high at any one time.

During cold or windy conditions, more heat is required.

Finally, resist the temptation to keep opening the hood while cooking. This will help to maintain a constant temperature, and minimise cooking time.

The cleaning and care instructions are essential for the proper functioning and operation of your appliance over time. Failure to adhere to these care instructions may affect your ability to make a claim under the manufacturer's warranty.

### Cleaning Enamel burner box

Although porcelain enamel will keep its lustrous finish even under adverse conditions, it still needs regular cleaning. After the appliance has been used, wash down the surfaces with hot soapy water. Caustic cleaners should be avoided. For barbecues near the ocean or salt-water environment, more frequent cleaning and servicing should be conducted. Wash regularly, rinse and then dry before covering. (In a salt water or marine environment, more rapid deterioration can be expected which is not covered by warranty).

### Cleaning Plates and Grills

Many food acids, marinades, juices and sauces contain highly acidic elements that will slowly attack the surface of the plates and grills if not removed after cooking.

- After use, remove all solid material from the cooking surfaces using a brass bristle brush or plastic scourer. Brushes specifically designed for this purpose can be purchased from your BeefEater retailer. Wipe off remaining residue with a paper towel.
- Wash the surface of the grills with a soft sponge and a solution of hot water and a mild dishwashing liquid. Do not use highly caustic, harsh or abrasive chemical cleaners to clean the cooking grills. Always check the manufacturer's recommendations for the cleaner prior to use.
- Coat the grills with a layer of cooking oil. This will help protect the surfaces between uses.

### Cleaning the grease tray

Never remove the grease tray while the barbecue is hot. Always remove and clean the grease tray after the unit has cooled down.

Replace aluminium foil drip tray and clean grease tray at regular intervals to prevent grease build-up. Otherwise, a grease fire could result and void the barbecue warranty.

### Cleaning the control panel and hood

Wash the surfaces of the control panel and hood with a soft sponge and a solution of hot water and a mild dishwashing liquid. Do not use highly caustic, harsh or abrasive chemical cleaners or scouring pads as these will damage the surface of the panels.

### Cleaning the Burners

- Check main opening of burner regularly for insect nests (eg. wasp, ants or spiders). Nests are dangerous and must be cleaned out thoroughly.
- Remove burners periodically and scrub clean with soapy water and a wire brush making sure that the ports are free of obstructions.

Replace burners in the correct position and dry by lighting each one to avoid subsequent corrosion.

### CAUTION

A clogged burner can lead to a fire beneath the grill.

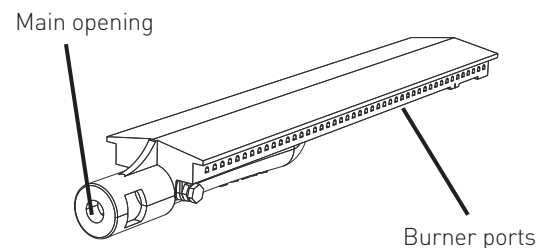

### Inspecting the hose and Regulator Assembly and Cylinder

- Inspect the hose and regulator assembly for abrasion, aging or any damage that may result in a gas leak at periodic intervals, at least once a year, and whenever replacing a cylinder.

Replace the assembly if necessary to ensure safe operation.

After connecting the assembly to a cylinder always carry out a leak check.

Only connect the appliance to cylinders that are current according to the date marking on the cylinder.

### Storing your Barbecue

When storing barbecue for extended periods, be certain all controls and cylinder valves are turned off.

Gas cylinders must be stored outdoors, out of reach of children and must not be stored in a building, garage or any other enclosed area.

The barbecue should be covered when not in use. A barbecue cover is available as an accessory.

The gas cylinder supply valve must be turned off when the appliance is not in use.

### WARNING

**Note:** For storage and cylinder exchange, disconnect hose at the cylinder only, do not disconnect hose from appliance.

# TECHNICAL INFORMATION

## EUROPEAN SPECIFICATION

### 1500 SERIES 3 BURNER BBQ

COUNTRY	BE,CH,CY,CZ, ES,FR,BG, GR, IE,IT,LT,LU, LV,PT,SK,SI		BE,CY,DK,EE, FR,GB,HU,IT, LT,NL,NO,SE, SI,SK,RO,HR, TR,BG,IS,LU, MT,FI		AT,CH,DE,SK	
GAS CATEGORY	<b>I<sub>3+</sub>(28-30/37)</b>		<b>I<sub>3B/P</sub>(30)</b>		<b>I<sub>3B/P</sub>(50)</b>	
GAS TYPE	G30 BUTANE	G31 PROPANE	G30 BUTANE	G31 PROPANE	G30 BUTANE	G31 PROPANE
GAS INLET PRESSURE [mbar]	28 - 30	37	30	30	50	50
INJECTOR Ø [mm]	1.00				0.85	
TOTAL HEAT INPUT	<b>12KW</b> G30:873g/h, G31:857g/h, G20:1.27m3/h					



#### CAUTION

READ THE INSTRUCTIONS BEFORE USING THE APPLIANCE. USE OUTDOORS ONLY.

**WARNING:** ACCESSIBLE PARTS MAY BE VERY HOT. KEEP YOUNG CHILDREN AWAY.

### 1500 SERIES 4 BURNER BBQ

COUNTRY	BE,CH,CY,CZ, ES,FR,BG, GR, IE,IT,LT,LU, LV,PT,SK,SI		BE,CY,DK,EE, FR,GB,HU,IT, LT,NL,NO,SE, SI,SK,RO,HR, TR,BG,IS,LU, MT,FI		AT,CH,DE,SK	
GAS CATEGORY	<b>I<sub>3+</sub>(28-30/37)</b>		<b>I<sub>3B/P</sub>(30)</b>		<b>I<sub>3B/P</sub>(50)</b>	
GAS TYPE	G30 BUTANE	G31 PROPANE	G30 BUTANE	G31 PROPANE	G30 BUTANE	G31 PROPANE
GAS INLET PRESSURE [mbar]	28 - 30	37	30	30	50	50
INJECTOR Ø [mm]	1.00				0.85	
TOTAL HEAT INPUT	<b>16KW</b> G30:1163g/h, G31:1143g/h, G20:1.693m3/h					



#### CAUTION

READ THE INSTRUCTIONS BEFORE USING THE APPLIANCE. USE OUTDOORS ONLY.

**WARNING:** ACCESSIBLE PARTS MAY BE VERY HOT. KEEP YOUNG CHILDREN AWAY.

**1500 SERIES 5 BURNER BBQ**

COUNTRY	BE,CH,CY,CZ, ES,FR,BG, GR, IE,IT,LT,LU, LV,PT,SK,SI		BE,CY,DK,EE, FR,GB,HU,IT, LT,NL,NO,SE, SI,SK,RO,HR, TR,BG,IS,LU, MT,FI		AT,CH,DE,SK	
GAS CATEGORY	<b>I<sub>3+</sub>(28-30/37)</b>		<b>I<sub>3B/P</sub>(30)</b>		<b>I<sub>3B/P</sub>(50)</b>	
GAS TYPE	G30 BUTANE	G31 PROPANE	G30 BUTANE	G31 PROPANE	G30 BUTANE	G31 PROPANE
GAS INLET PRESSURE [mbar]	28 - 30	37	30	30	50	50
INJECTOR Ø [mm]	1.00				0.85	
TOTAL HEAT INPUT	<b>20KW</b> G30:1163g/h, G31:1143g/h, G20:1.693m <sup>3</sup> /h					

**CAUTION**

READ THE INSTRUCTIONS BEFORE USING THE APPLIANCE. USE OUTDOORS ONLY.

**WARNING:** ACCESSIBLE PARTS MAY BE VERY HOT. KEEP YOUNG CHILDREN AWAY.

## TROUBLESHOOTING

PROBLEM	CAUSE	CHECK
Barbecue will not light	Ignition system not working	Check to see visible spark at starter probe - if no spark is present when control knob is turned then the unit may need to be serviced or replaced. Contact your BeefEater dealer. Check that there is a visible flame coming from the pilot ignition tube. Check that the pilot ignition tube is not blocked by spider webs or insect nests.
	Turning on gas control too quickly	Allow at least 5 seconds for gas to flow through burner before ignition.
	No gas flow	Check that valve on gas cylinder is turned on. Check that burner ports are free of obstructions. Check that all gas injectors are clean and free of obstructions.
	Burners not assembled correctly	Check that burners are correctly positioned in the barbecue frame.
	Burner ports or throat blocked	Check that the burner ports are not blocked by spider webs or insect nests. Clean out as required.
Barbecue lights but goes out soon after starting	Fuel supply turned off	Turn on gas valve at cylinder.
	Gas cylinder low or empty	Replace cylinder and carry out a leak check.
	Kink in gas hose	Check that the gas line is not kinked or twisted.
	Wind or breeze affecting operation	Ensure that the appliance is located out of the way of wind.
Burners will not cross light from one to the other		Check that cross light channel is in place. Check that burner ports are free of obstructions.
Low flame level or low heat output	Burners will not cross light	Check you are running on correct gas Check gas injector size is correct.









FOR SALES IN EUROPE  
 APPLIANCE: BEEFEATER INTEGRATED BARBECUE

**Should any part fail due to defective workmanship or faulty materials within the specified period from the date of purchase, BeefEater or its distributor will repair or, (at distributors option), replace the defective part free of charge.**

**• LP / Propane Gas Cylinder**

The cylinder manufacturer is responsible for the materials, workmanship and performance of the gas cylinder. Contact your dealer or the cylinder manufacturer in respect of all warranty claims or service.

**• Warranty Administration**

In Australia, warranty is administered by BeefEater Barbecues. In other countries, contact your authorised BeefEater retailer for details of your BeefEater distributor.

- To ensure speedy processing of your warranty service claim, ensure that you record all specific details about your appliance in the space provided. Keep this information handy for future reference.

**Not covered**

Exposure of the barbecue appliance to the elements should be minimised. Once the unit has cooled and is cleaned, store the barbecue under cover. Polyester/ Vinyl barbecue covers are an optional accessory that will ensure years of trouble free operation.

This warranty does not cover the purchaser or any other person for damage, malfunction or loss due to the following:

- Lack of maintenance, abuse, neglect, misuse, accident or improper installation of this appliance.
- Scratches, dents, corrosion or discolouring caused by heat, abrasive or chemical cleaners or chipping on porcelain parts.
- Corrosion or damage caused by exposure to the elements, grease fires, insects, weather or hail. Note: Barbecues must be covered when not in use.
- Cleaning and normal wear and tear. Service calls of this nature are chargeable.
- Rusting of cast iron plates, grills and burners. Note: Rust should be removed by a scrub pad and the surface coated with cooking oil. See owners manual – Caring for cast iron cooking surfaces. Cooktops must be covered when not in use.
- Commercial use of the barbecue.
- Unauthorised repairs during the warranty period
- Removal or re-installation costs.

**Conditions of Warranty**

1. The appliance is delivered to the BeefEater distributor's service department or authorised service agent and freight charges both ways are paid by the owner. No liability is accepted for loss or damage during transit.
2. The appliance is operated and maintained in accordance with the instructions supplied. Repairs or service must be carried out by an authorised person.
3. Installation must conform to the applicable Gas, Electrical and Building standards laid down by the local codes for your country or region.
4. No alterations or repairs have been carried out without obtaining the distributors prior consent. Such repair or any replacement does not extend the warranty period.
5. Proof of purchase together with the warranty card must be provided to verify purchase date and establish the warranty period. Only the original purchaser is covered under this warranty.
6. The warranty period is calculated from the date of purchase only.
7. Where this warranty is inconsistent with any state laws, the statutory rights of the purchaser shall prevail.
8. Parts installed from other manufacturers' products will void this warranty.

**Service assistance**

To assist you when contacting your after sales service contact to arrange a service call please complete the following details and have them ready when you call. You do not need to register your warranty. However, you must retain your receipt or proof of purchase. When claiming warranty for this appliance you must provide a copy of your proof of purchase receipt. No claims for warranty will be accepted without proof of purchase.

**TERMS OF WARRANTY (YEARS)**

Barbecue	
Stainless Steel burner box	25
S/S burners	5
Cast iron cooktops	3
Valves	2
Ignition system	2
All other parts	2
Hood	
Hood	2
Cast alloy parts	2
All other parts	2

For more information on all Beefeater products, or for dimension and installation information, call into your retailer, phone or email our customer care team or visit our website:

## **EUROPE**

**BeefEater Europe**

**PO Box 1238**

**Cheddar**

**BS27 9AH**

**United Kingdom**

phone UK: **+44 (0) 8455 436001**

phone EU: **+44 (0) 1934 743362**

email: **sales@beefeaterbarbecues.co.uk**

web: **www.beefeaterbbq.com**

BeefEater. We are part of the Electrolux Family.  
To add a touch of professional inspiration to  
your home, visit [electrolux.co.uk](http://electrolux.co.uk)