



Making British gardens great

Thank you for purchasing your shed from Forest Garden. No matter what size garden, a shed is the most practical of garden structures. Simply follow these step by step instructions and our top tips and you'll be enjoying your shed for many years to come. If you have any questions or need advice, our friendly team is here to help.

SHED INSTRUCTIONS

PENT SHEDS (SIZE RANGE 7x5, 8x6)

FIXING PACK CONTAINS:

FIXING PACK CODE: *TPP86MFP*

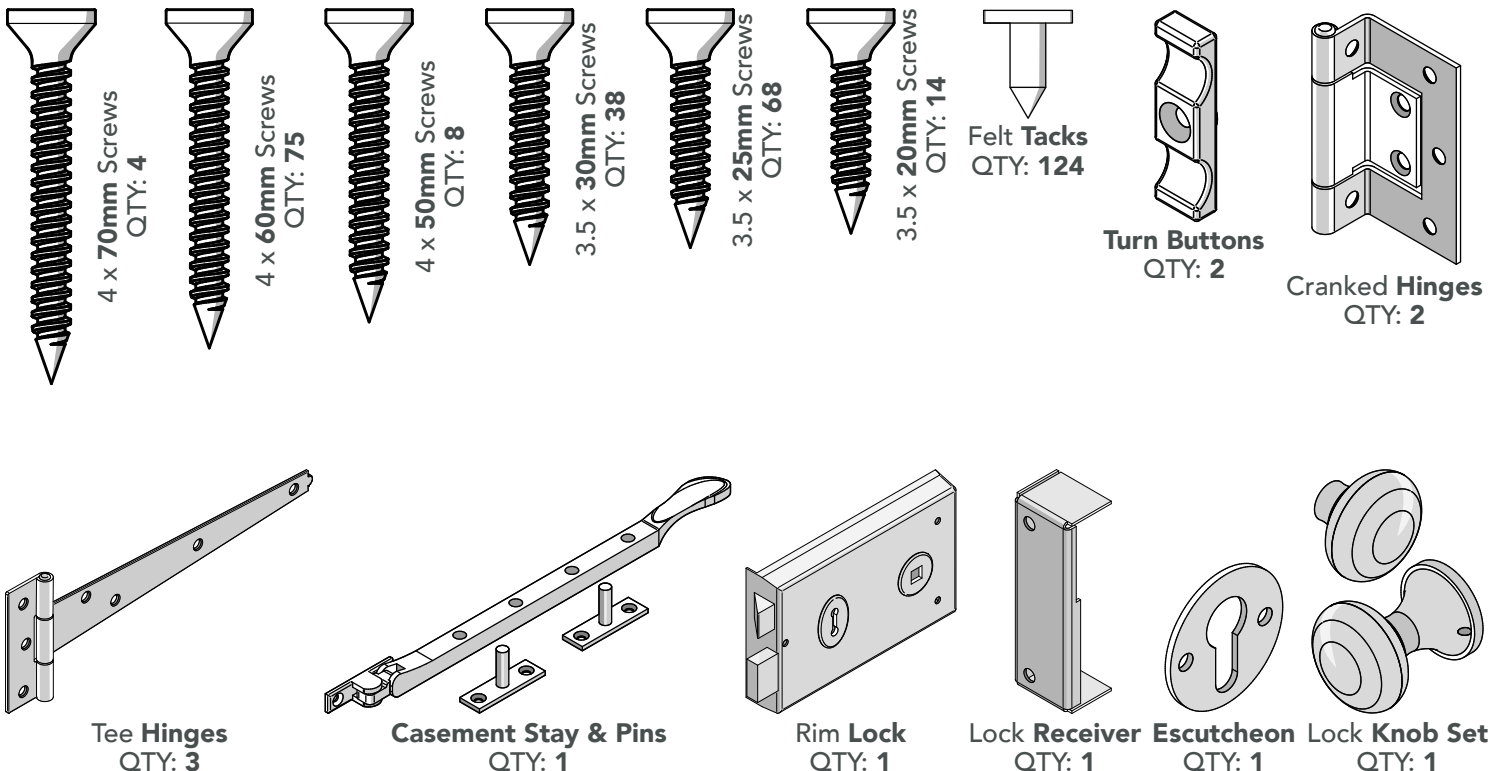

Missing something or need more information?

Call our aftersales team on
0333 321 3142

Visit our website for spare instructions and more information

www.forestgarden.co.uk

BEFORE YOU START

Please read through these instructions to familiarise yourself with your shed. We recommend that you **check all the components** using the lists found on the front and back pages before you start to build.

All of our sheds are constructed in the same way. They simply come with different components depending on the type of shed you have. Don't worry if your fixing pack contains some spare items at the end of the build (you haven't missed a bit!) we have sent you a generic fixing pack to suit the shed range.

Please take care when unpacking, handling and assembling the toughened safety glass windows. We recommend wearing cut-resistant gloves in the event of a breakage, as it will disintegrate into small pieces.

BASE PREPARATION

It's vital that you build your new shed on a **solid, level base**. Timber or Plastic Shed Bases are ideal, as is solid concrete or concrete slabs.

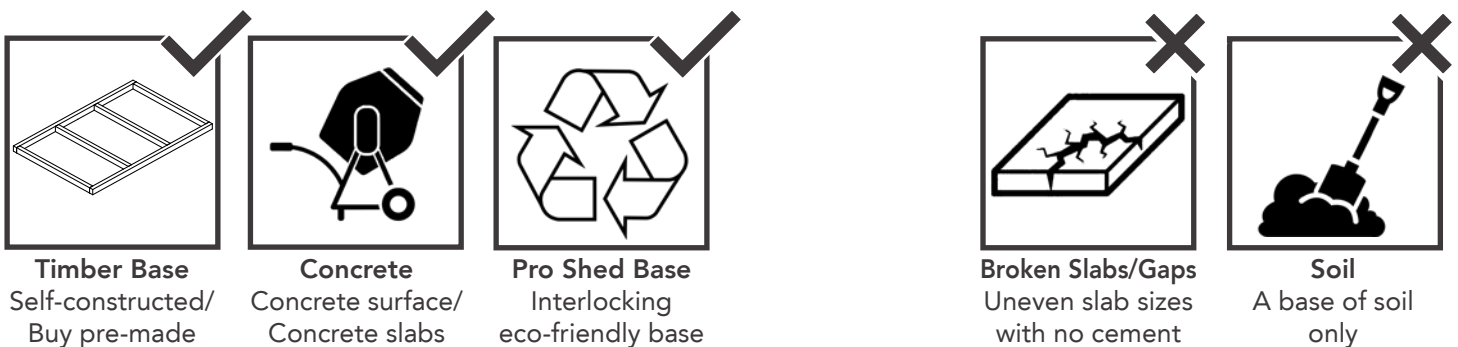

If you have an existing base and think it's suitable for your new shed to be sited on, it is important you check that it is level and doesn't deviate by any more than 15mm from edge to edge. If this isn't the case the building will twist, causing gaps to appear in the sections and the roof, doors and windows to misalign.

There's more information on base preparation on our website www.forestgarden.co.uk

TOOLS NEEDED

We recommend using the following tools (not supplied):

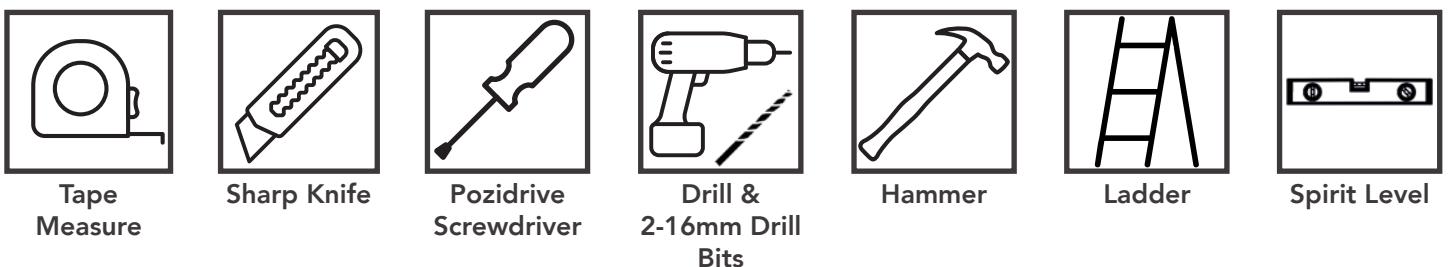

Assembly is relatively straightforward if you follow these step by step instructions. We recommend getting everything aligned properly before screwing together and that **screw holes should be pre-drilled** to avoid splitting the timber.



IMPORTANT
Assembly requires 2+ adults.



REMINDER
Always pre-drill before screwing.

PLEASE KEEP PLASTIC BAGS AND SMALL PARTS AWAY FROM CHILDREN

To help you get the most out of our products it's useful to know a little more about the properties of timber, what's normal and how your shed may behave as the seasons change. Wood is an extremely durable material for construction but as a natural product when used outdoors it is susceptible to changes in the environment.

THINGS THAT YOU MIGHT SEE IN YOUR PRODUCT



MOVEMENT, TWISTING & WARPING

Wood contains a natural level of moisture so decreasing humidity levels in the surrounding air may cause panels to change their shape as the porous fibres shrink. This can be exaggerated during prolonged periods of dry weather. Movement and gaps in timber products are normal, in most cases the wood will revert to its original form once the high temperatures subside and there is more moisture content in the air. Similarly, in the winter months, the opposite may occur with wood swelling.

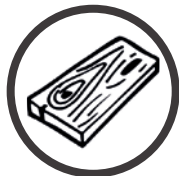

EXPANSION, CONTRACTION, SPLITS & CRACKS

All timber will expand and contract according to its environment. As a result of this expansion and contraction, it is very common to see splits and cracks developing in the wood. Splits are common during the spring and summer months as the wood begins to dry out. The outer surface dries first and contracts, contracting over a still expanded core of the wood. The result of this is that splits and cracks appear along the grain of wood. These splits are not a fault and do not affect the structural integrity of a product.



MOULD & BLUE STAIN

Mould is a surface-dwelling fungus that feeds on the nutrients and debris contained in the surface cells of timber. The most common problems associated with mould are discoloured timber and an increase in permeability of the timber. Blue stain is part of the same family but penetrates deeper into the surface layers of the timber. It stains the timber a dark blue, whereas mould is usually black. These do not cause the timber to rot. Keep the building well ventilated to avoid mould.

Treat your building annually, we advise the application of a high quality preservative that contains a mildewcide. For more information on the conditions of our guarantee see forestgarden.co.uk.

ADVICE ON FELT HANDLING & USAGE

Roofing felt is flexible at temperatures above 5°C. In cold temperatures extra care must be taken when handling and installing to prevent cracking and damage to the felt. The felt should not be rolled, folded or used in temperatures lower than 5° C. In cold temperatures the felt should be stored above 10°C (indoors) for 24 hours prior to use. Felt must be lifted, not dragged and should be stored on its end on a dry surface.

THE ROOF OF THIS BUILDING IS NOT A LOAD BEARING STRUCTURE

8 TOP TIPS TO ENSURE YOUR SHED IS FULLY WATERPROOF

- 1 MAKE SURE YOU POSITION YOUR SHED IN THE BEST LOCATION IN YOUR GARDEN**
Avoid areas where water pools and is constantly wet. Position away from trees and cut back any overhanging foliage which can cause moisture to be trapped against shed walls and debris to collect on the roof.
- 2 RAISE YOUR SHED OFF THE GROUND**
Ideally any concrete base should be the same footprint as the shed to allow surface water to run off without pooling, a timber shed base can also be used. Raise 50mm above ground level.
- 3 SEAL THE BASE**
We recommend a treatment containing wax or oil, paint the bearers that come into contact with the ground to prevent moisture coming up.
- 4 USE AN END-GRAIN PROTECTOR**
To protect the corners and panel joints, an end grain treatment can be applied.
- 5 SEAL THE PANELS & WINDOWS**
Use a flexible silicone sealant around windows to prevent water ingress. This can also be used where 2 sections of the shed joint together. Apply internally.
- 6 CONSIDER ADDING GUTTERS**
Adding guttering around the fascia of the shed will redirect rain water away from the shed's foundation.
- 7 KEEP VENTILATED**
Good airflow around the perimeter of the shed and regular ventilation inside the shed will help prevent mould and mildew.
- 8 CONSIDER A WEATHERPROOFING STAIN OR CLEAR TREATMENT**
We recommend you paint your garden shed with a weatherproofing treatment at least once a year. This will help maintain the wood, stabilise timber movement and help prolong the life of your shed.

HEALTH & SAFETY

We strongly recommend that PPE (Personal Protective Equipment) is used throughout your build to ensure you are protected from any potential health and safety risks. Do not exempt yourself from wearing PPE.



IDENTIFY YOUR SHED

From the **section layout** below, identify your shed based on the **width** and **depth** dimensions – eg 7x5. You'll need this to identify the side panel positions. Use the key and visuals below as a guide.

KEY

A Plain Panel
(323 x 1831mm)

B Plain Panel
(328 x 1831mm)

C Plain & Window Panel (852 x 1831mm)
(These panels are interchangeable)

D Plain & Window Panel (1114 x 1831mm)
(These panels are interchangeable)

E Plain Panel
(1180 x 1831mm)

F Door Panel
(1180 x 1831mm)

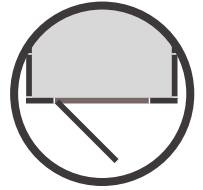

The door is flexible for all shed types and can be hinged onto either side.

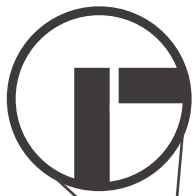

Indicates the panel orientation during construction. This will apply to all of the corners for your chosen shed.

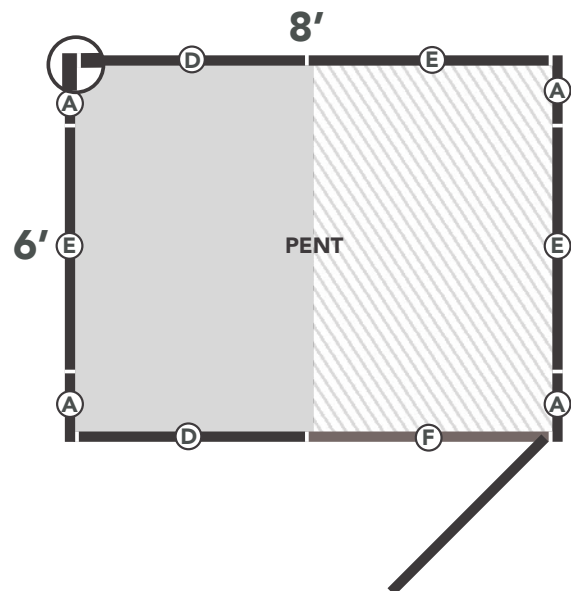
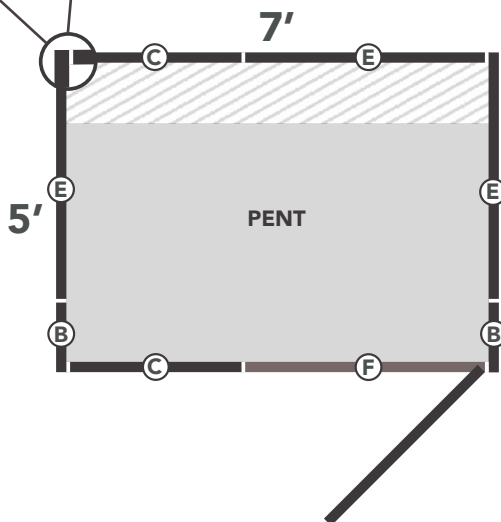

PANEL POSITION

When assembling your wall panels, ensure the **timber framing** on the panels are **flush** at the corners. The space left next to the board is for the cover strip to sit into. Ensure to apply the same panel position to all corners.

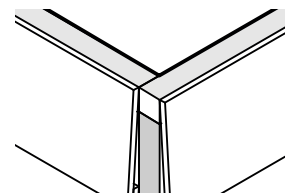

Please note that the below visuals use the 8x6 pent shed as a guide. The assembly steps still apply to both shed types unless specified in the text.

1a FLOOR & PANEL LAYOUT



Position the floors in your desired location. Turn the floors upside down to **secure the sections together** by screwing through the adjoining bearers.

50MM SCREWS

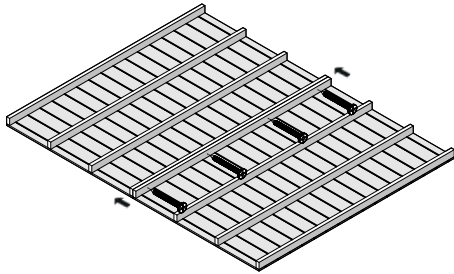

Layout the panels around your shed base.

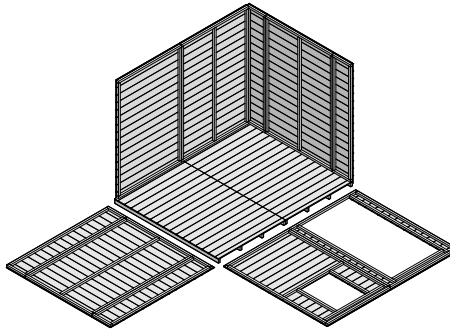

We recommend to start in a back corner then **work from the back panels to the front panels** for assembly.



1b SIDE PANELS



Start at a **back corner**. See the section layout on page 4 to confirm position. Secure the corner as shown below.

EG. INSIDE CORNER

60MM SCREWS

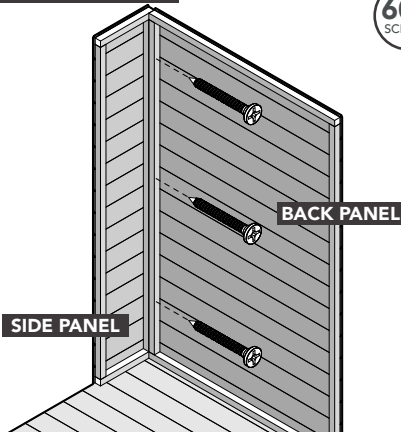

Repeat the process for the remaining panels and **secure the panels together**. Make sure that the bottom frame of the wall panel rests on the outer edge of the floor.

EG. BACK PANELS

60MM SCREWS



Secure the panels into place by **screwing into the floor bearers**. Use 4 x screws for the larger panels and 1 x screw for the smaller panels as shown in the bottom visual.

EG. INTO FLOOR BEARERS

60MM SCREWS

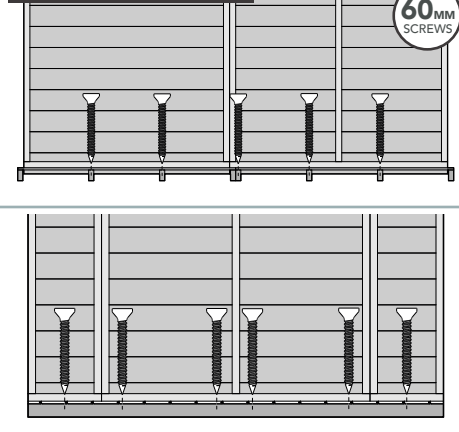

1c APEX SECTIONS



Attach the **Infill Panels** by screwing to the front wall panels as shown below.

60MM SCREWS

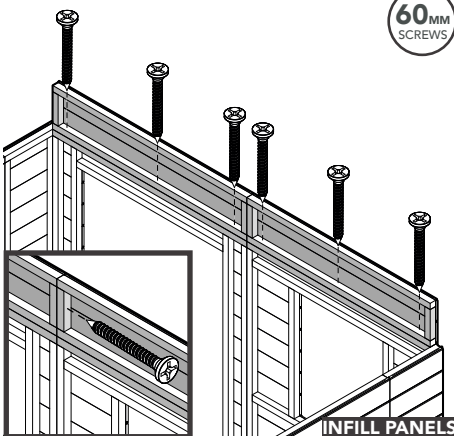

Attach the **Right Pent Section** to the side panels by screwing to the wall panels and Infill Panel as shown below.

60MM SCREWS

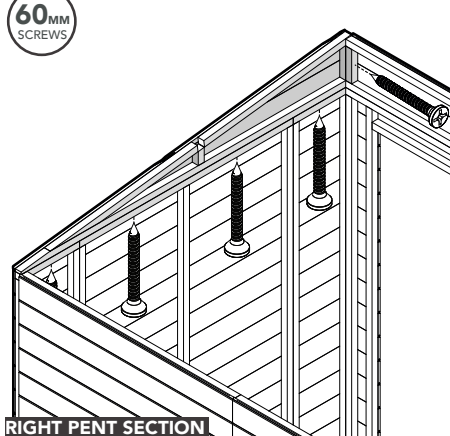

Attach the **Left Pent Section** to the other side panels by screwing to the wall panels and Infill Panel as shown below.

60MM SCREWS

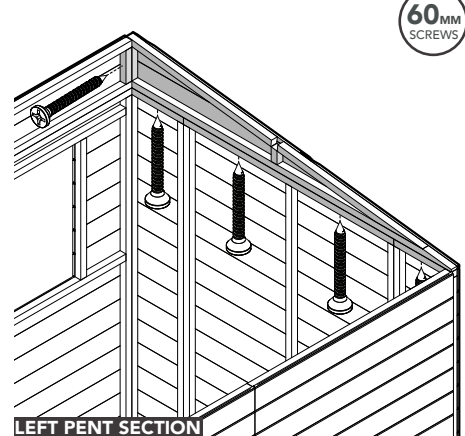

2 COVER STRIPS & DOOR STRIPS



Attach the Back Cover Strips to the back corners and back adjoining panels. Ensure they are flush to the bottom edge of the panels as shown below.

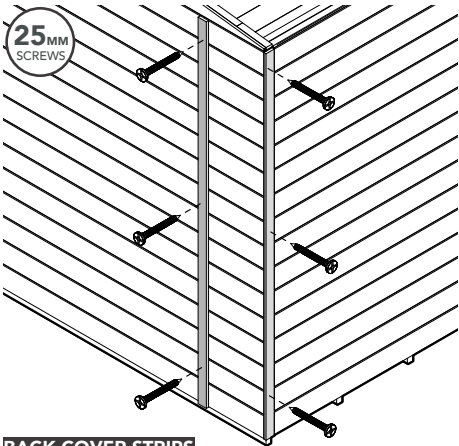

BACK COVER STRIPS

Attach the Front Cover Strips to the front corners and front adjoining panels. The 7x5 shed only will have longer Front Cover Strips on the front panels.

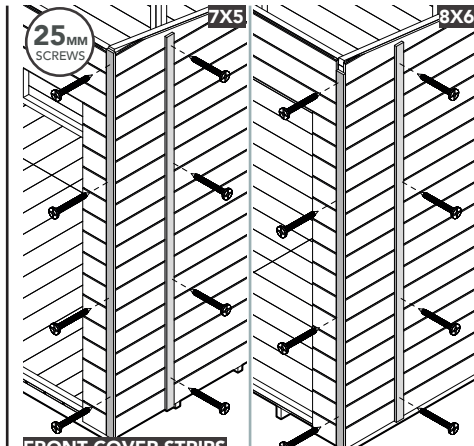

FRONT COVER STRIPS

Secure the Door Weather Strips. Ensure they are in contact with the door batten and flush to the panel frame.

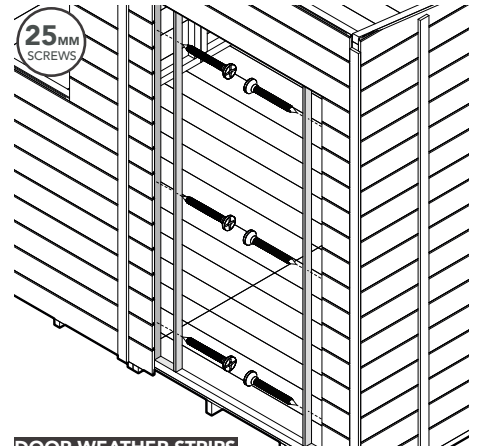

DOOR WEATHER STRIPS

3a ROOF ASSEMBLY



(7x5 only) Fix the Roof Batten to the top of the front panels. Ensure it is flush to the framework.

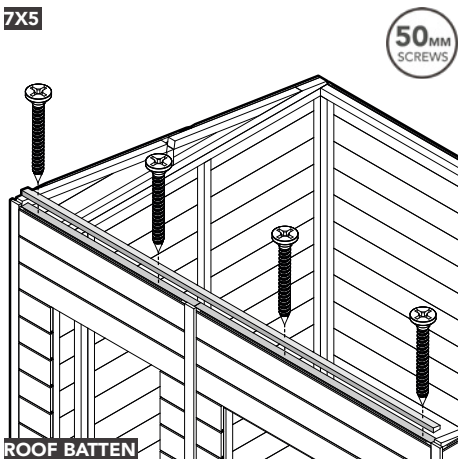

ROOF BATTEN

(8x6 only) Fix a Truss Support Block to the centre of your front panels (In between the Pent Sections). Use the measurement below as a guide.

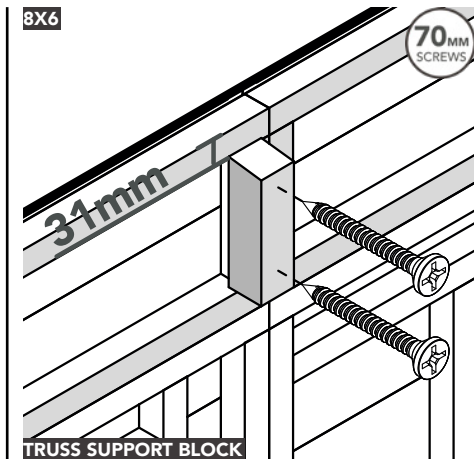

TRUSS SUPPORT BLOCK

(8x6 only) Fix a Truss Support Block to the centre of your back panels. Ensure the angle is in the same direction as the other Truss Support Block.

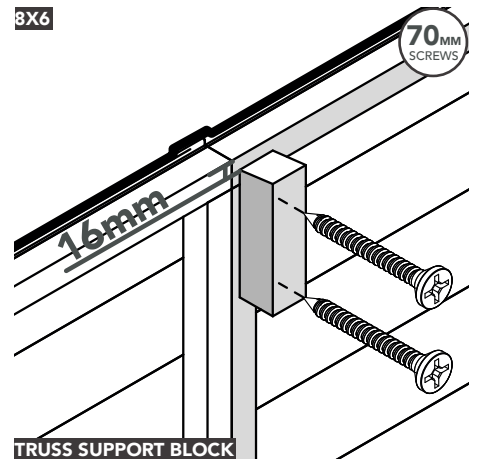

TRUSS SUPPORT BLOCK

3b ROOF ASSEMBLY



Secure the Roof Panel to the Pent Section and wall panels. The Roof Panels frame will slot into the Pent Sections frame.

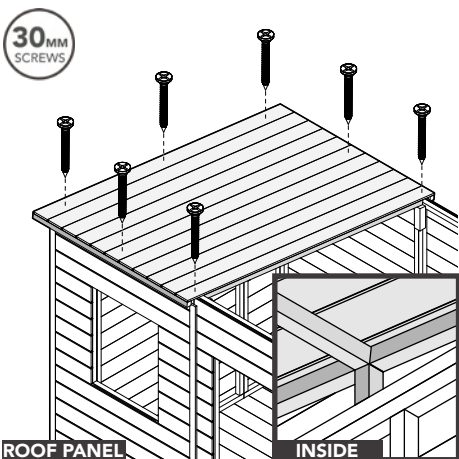

ROOF PANEL

INSIDE

Secure the other Roof Panel to the Pent Section and wall panels. The Roof Panels frame will slot into the Pent Sections frame. Ensure the Roof Panel is butt up against the other Roof Panel.

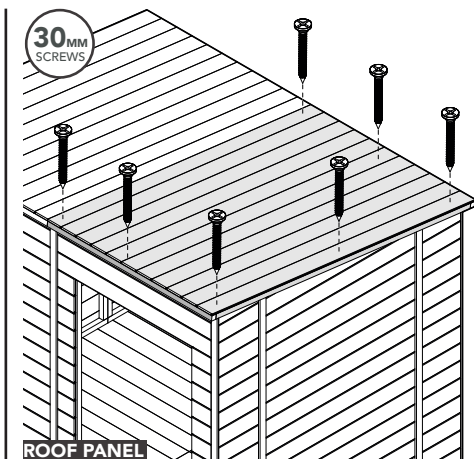

ROOF PANEL

Fix the Roof Panels together, through the adjoining framework.

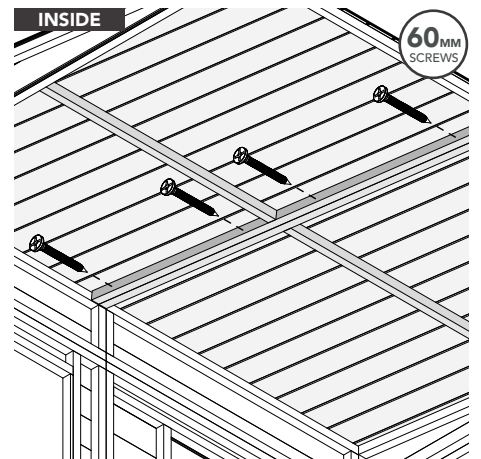

INSIDE

60MM SCREWS

4 ROOF FELT, FASCIAS & FINIALS

 PRE-DRILL WITH 2MM BIT FOR ALL STEPS BELOW.

Measure out 3 equal lengths of felt. Overlap it on the top and around the edges. Fold at the corners. Tack to keep secure. Ensure 50mm of the felt covers the roof end battens. Tack from the bottom to the top.

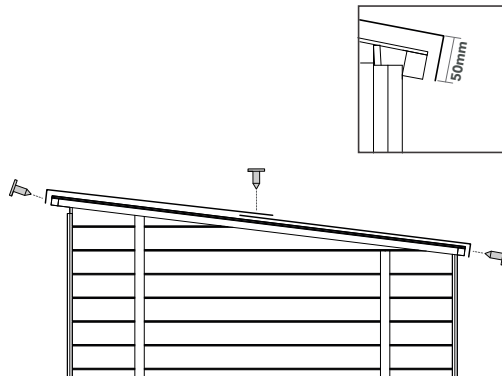

Secure the Side Fascias with screws to the Roof Panel framework as shown below. Ensure each Side Fascia is flush to the Roof Panel.

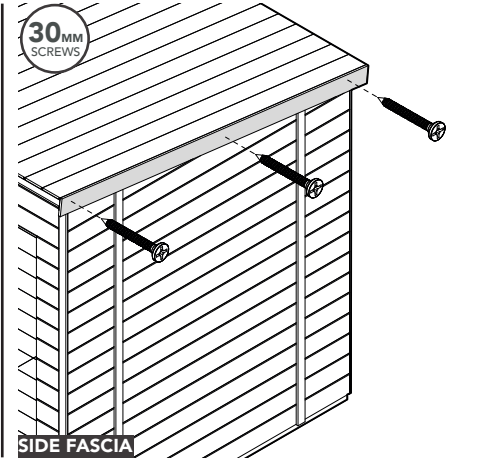

Secure the Front and Back Fascias with screws to the Roof Panel framework as shown below.

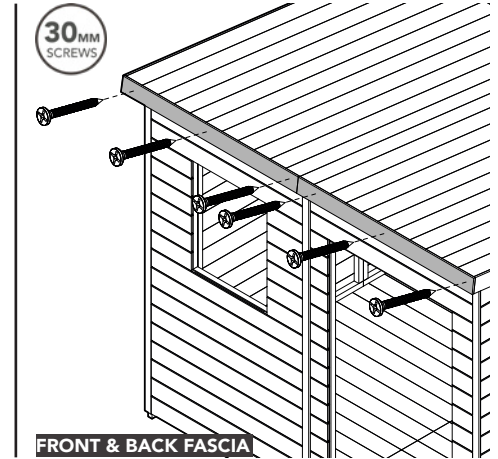

TOP TIP: Use a measuring tape to measure out 3 equal lengths & cut with a sharp knife. Hammer the tacks into the felt. Add the tacks at 150mm intervals.

5 WINDOW ASSEMBLY

 PRE-DRILL WITH 2MM BIT FOR ALL STEPS BELOW.

Attach the Cranked Hinges to the Window. Use the measurement provided as a positioning guide.

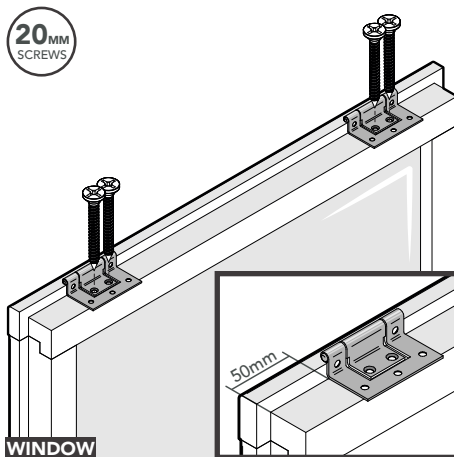

Secure the Window to the Window Panel framework. Ensure the pin on the hinges hook onto the T&G board on the front of the Window Panel and the window can open easily before securing into place.

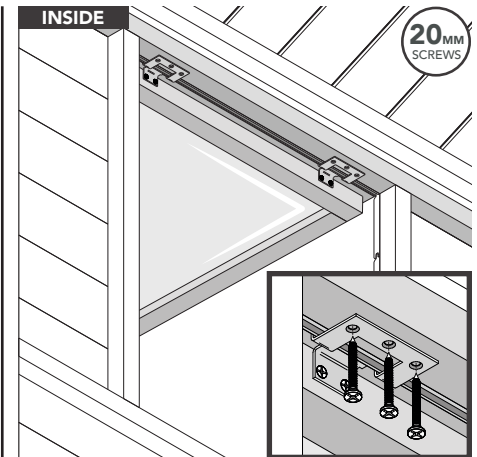

Secure the Casement Stay & Pins to the Window and interior sill. Secure the Casement Stay with its supplied screws and use it to position the pins underneath. Mark out first to ensure they align.

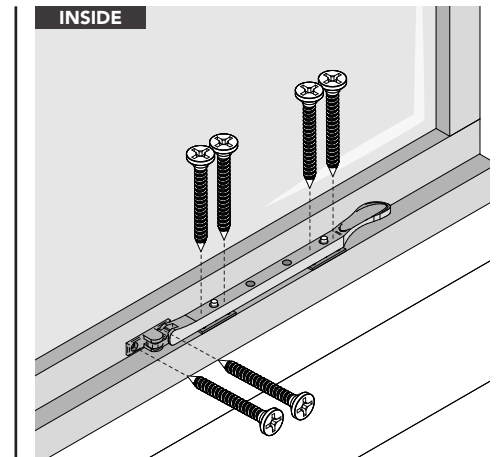

6a DOOR ASSEMBLY

 PRE-DRILL WITH 2MM BIT FOR ALL STEPS BELOW.

Make sure the outer face of the notch on the hinge is in line with the door edge.

HINGE POSITION

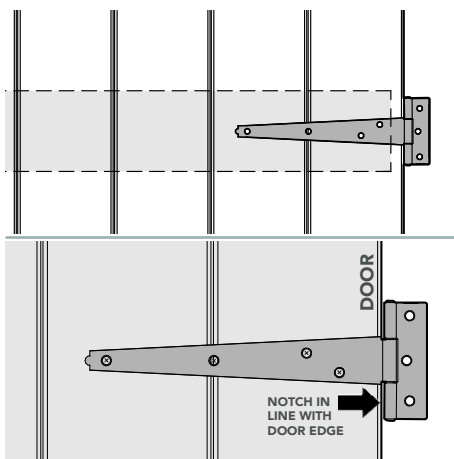

Position and attach the hinges to the framework behind on the Door. Please take note of the hinge position.

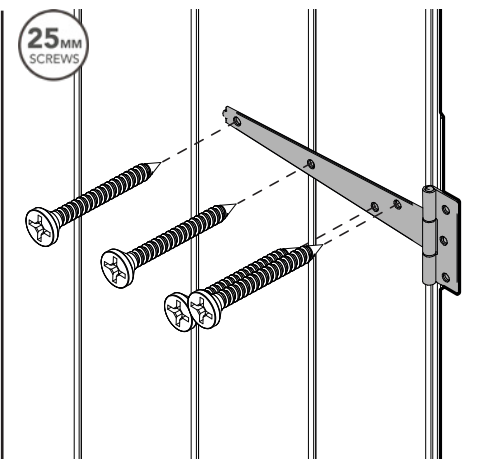

Place the Door into the opening, ensuring it's level. Make sure the hinges are up against T&G boards and fix into place.

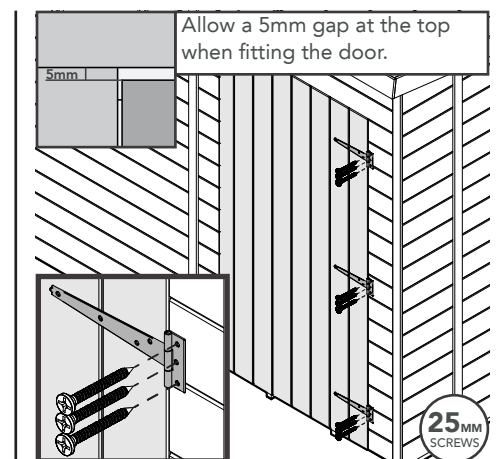

6b DOOR LOCK



Fix the Lock Block flush to the corner of the framework on the back of the Door.

Use a 16mm drill bit for the Door Handle hole. Use the Escutcheon as a guide with 5-8mm drill bits and drill 3 x holes to provide the hole for the key.

Secure the Rim Lock to the Lock Block with its supplied fixings. Ensure to hook the Rim Lock over the edge of the Lock Block. Thread the spindle through to attach the Handle.

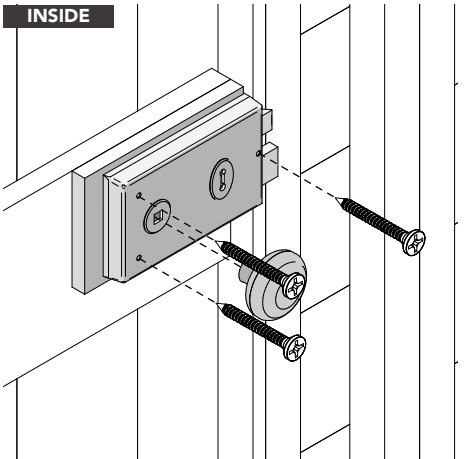
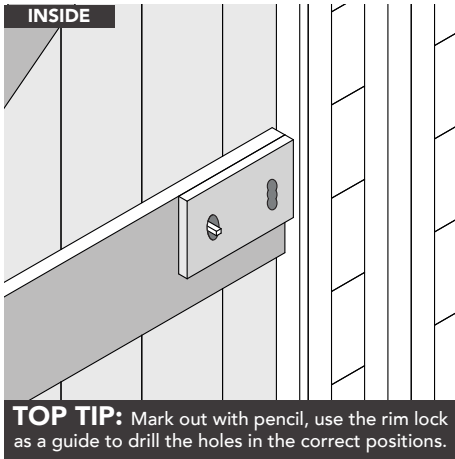
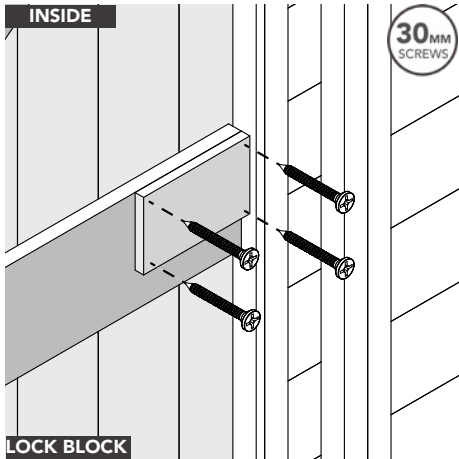

6c DOOR FIXINGS



Attach the Door Handle and Escutcheon to the external face of the Door using their supplied fixings.

Position and secure the Rim Lock Receiver to the framework. Test the key to ensure the lock works accordingly.

Attach a turn button at the top and bottom of the Door Panel.

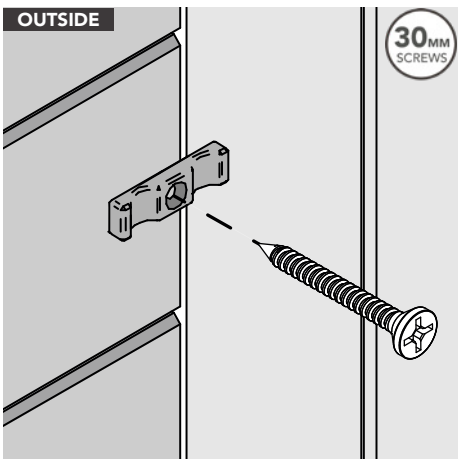
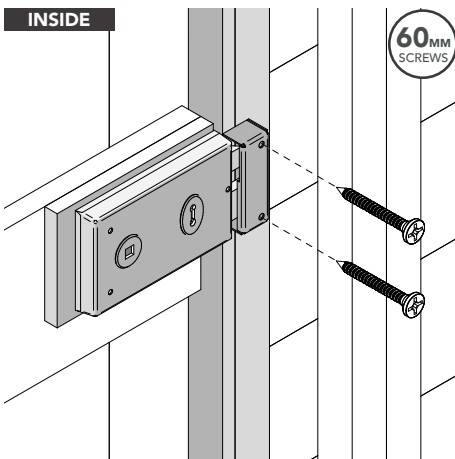
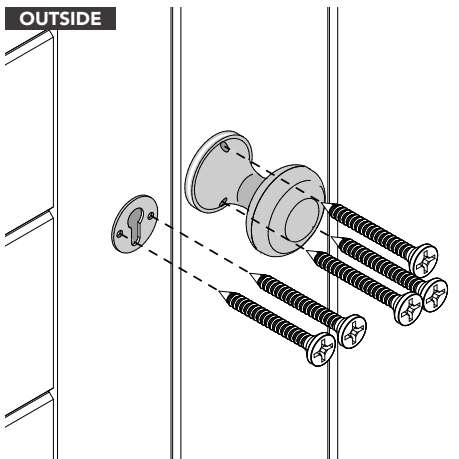

CHECK YOU HAVE ALL YOUR PARTS.

(The parts do not have codes on them. They are listed below should you need to order one.)

The components provided may be heavy. Please lift with caution and with a minimum of 2 people.

T&G Pent 7' x 5' - 1 Window (TPP75M)			
Label	Part Code	Description	No.
B	TPMOD328	Section B - Plain Panel (328x1831mm)	2
C	TPMODPP852	Section C - Plain Panel (852x1831mm)	1
D	TPMODW852	Section C - Window Panel (852x1831mm)	1
G	TPMODPP1180	Section E - Plain Panel (1180x1831mm)	3
H	TPMODDP	Section F - Door Panel (1180x1831mm)	1
I	TPMOD75FL1180	Floor (1180x2098x70mm)	1
J	TPMOD75FL328	Floor (328x2098x70mm)	1
K	TPMOD1180FILL	Infill Panel (235x1180mm)	1
M	TPMOD852FILL	Infill Panel (235x852mm)	1
N	TPMOD75RHCH	Right Pent Section (251x1592mm)	1
O	TPMOD75LHCH	Left Pent Section (251x1592mm)	1
P	45121820PPT	Back Cover Strip (45x12x1820mm)	3
Q	45122000PPT	Front Cover Strip (45x12x2000mm)	2
R	45122068PPT	Front Cover Strip (45x12x2068mm)	3
S	33121631PPT	Door Weather Strip (33x12x1631mm)	2
T	3332032BN09PT	Roof Batten (33x33x2032mm)	1
V	TPP75MRF	Roof Panel (1110x1681mm)	2
Y	95121681PPT	Side Fascia (95x12x1681mm)	2
Z	95121122PPT	Front & Back Fascia (95x12x1122mm)	4
AA	TPASWIN	Window (558x695mm)	1
AB	MTGSH86DR	Door (883x1705mm)	1
AC	95150150PPT	Lock Block (95x15x150mm)	1
AD	Felt - Please contact our aftersales team with your product code if you are missing your felt.		1

T&G Pent 8' x 6' - 1 Window (TPP86M)			
Label	Part Code	Description	No.
A	TPMOD323	Section A - Plain Panel (323x1831mm)	4
E	TPMODPP1114	Section D - Plain Panel (1114 x 1831mm)	1
F	TPMODW1114	Section D - Window Panel (1114 x 1831mm)	1
G	TPMODPP1180	Section E - Plain Panel (1180x1831mm)	3
H	TPMODDP	Section F - Door Panel (1180x1831mm)	1
I	TPMOD86FL1180	Floor (1180x1826x70mm)	2
K	TPMOD1180FILL	Infill Panel (235x1180mm)	1
L	TPMOD1114FILL	Infill Panel (235x1114mm)	1
N	TPMOD86RHCH	Right Pent Section (237x1826mm)	1
O	TPMOD86LHCH	Left Pent Section (237x1826mm)	1
P	45121820PPT	Back Cover Strip (45x12x1820mm)	5
Q	45122000PPT	Front Cover Strip (45x12x2000mm)	5
S	33121631PPT	Door Weather Strip (33x12x1631mm)	2
U	45450150PAI07PT	Truss Support Block (45x45x150mm)	2
W	TPP86MLHRF	Left Roof Panel (1240x2000mm)	1
X	TPP86MRHRF	Right Roof Panel (1240x2000mm)	1
Y	95122000PPT	Side Fascia (95x12x2000mm)	2
Z	95121252PPT	Front & Back Fascia (95x12x1252mm)	4
AA	TPASWIN	Window (558x695mm)	1
AB	MTGSH86DR	Door (883x1705mm)	1
AC	95150150PPT	Lock Block (95x15x150mm)	1
AD	Felt - Please contact our aftersales team with your product code if you are missing your felt.		1

Use the labelled components to help identify the part code and description.

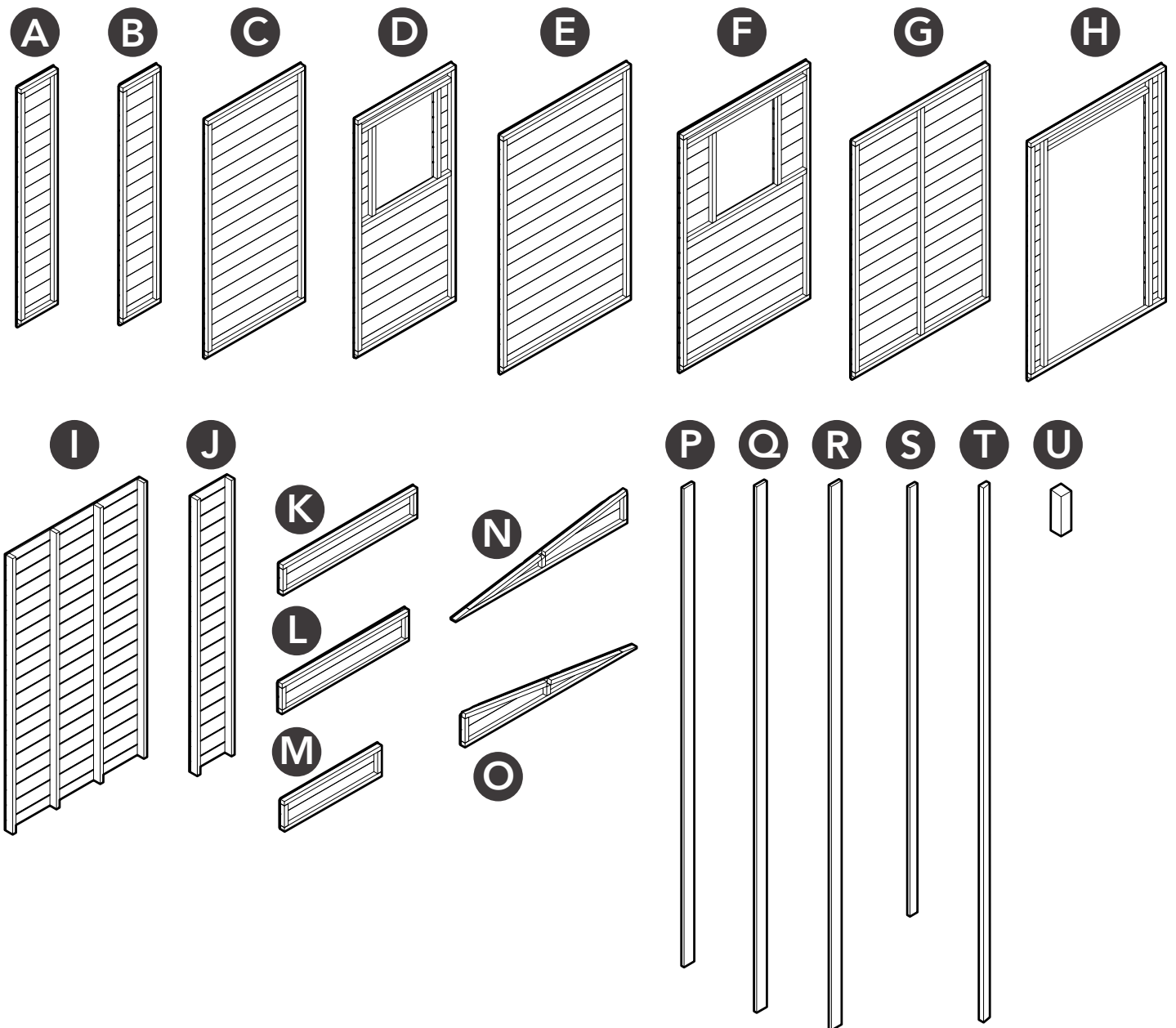

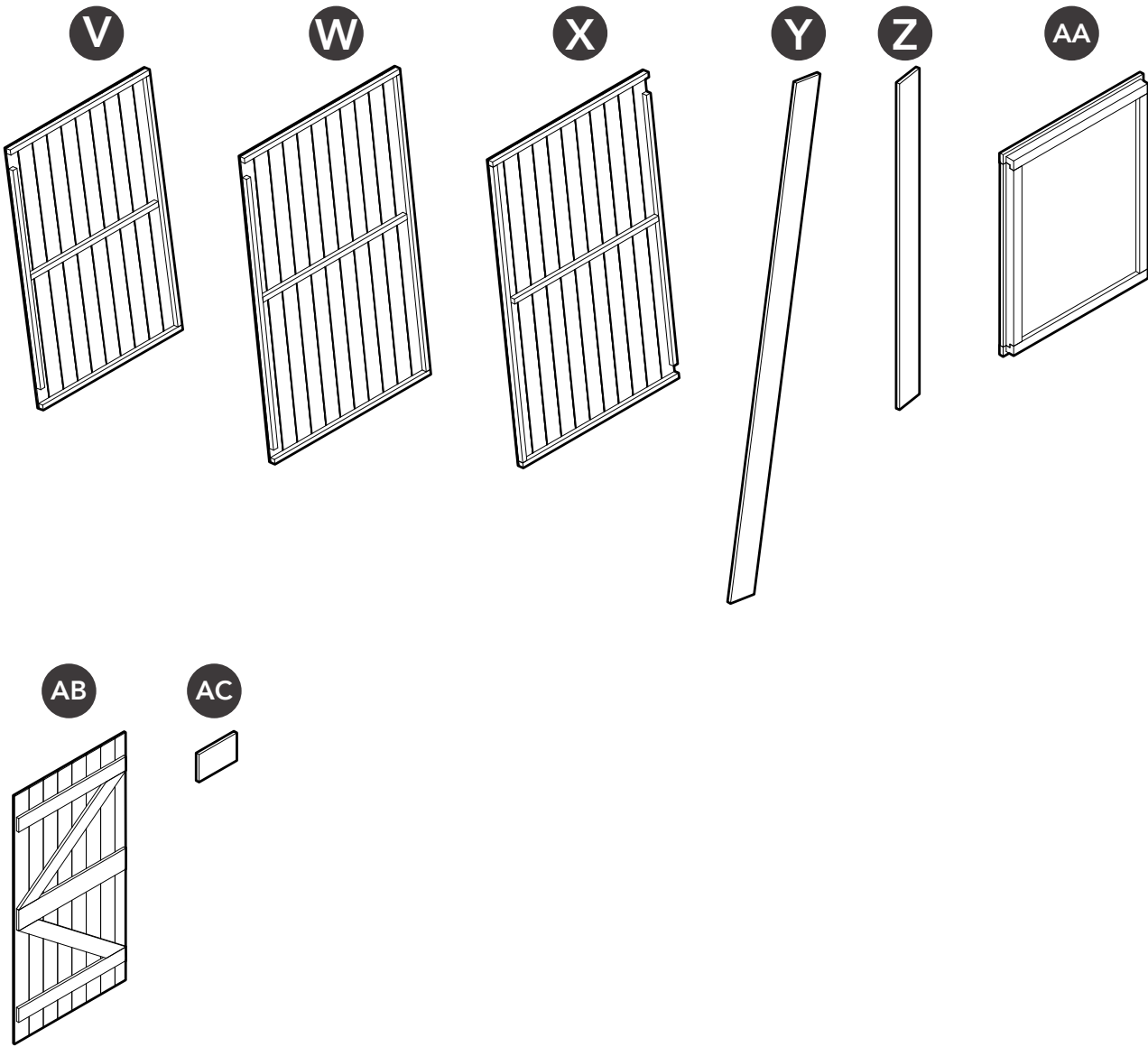

TREATED TIMBER CONTAINING A BIOCIDAL PRODUCT
CONTROL OF WOOD DESTROYING ORGANISMS

Active Ingredients - Basic Copper Carbonate, Benzalkonium Chloride. (Pressure Treated Sheds)

For use in above-ground and in-ground conditions. Wear gloves when handling freshly treated wood. Avoid breathing wood dust, treated or untreated. Do not burn off-cuts.