

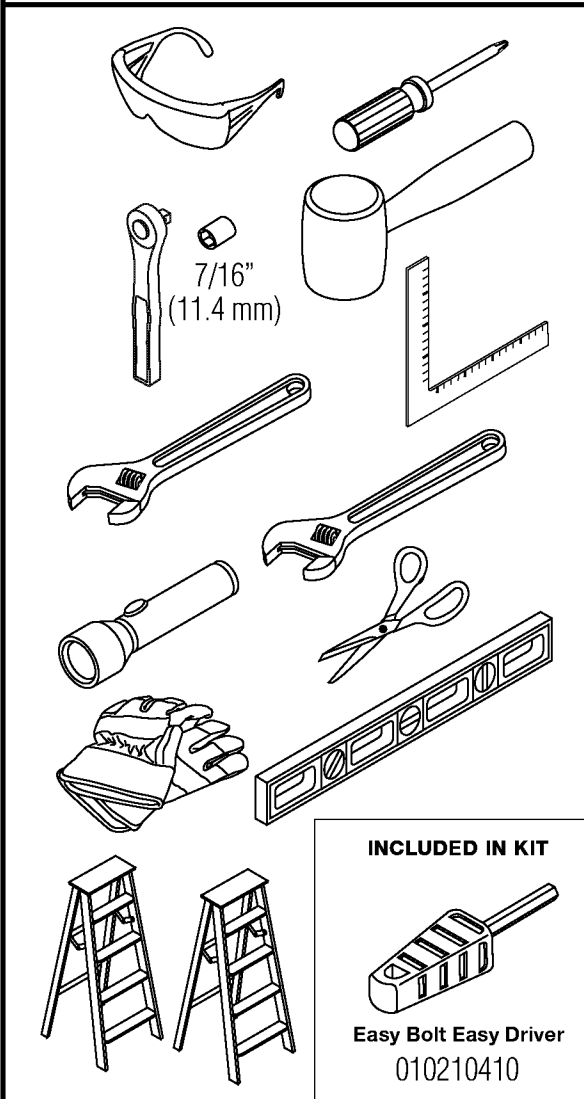

Tools Needed for Installation



BMS8700

Blow Molded Resin Storage Shed **ASSEMBLY INSTRUCTIONS**

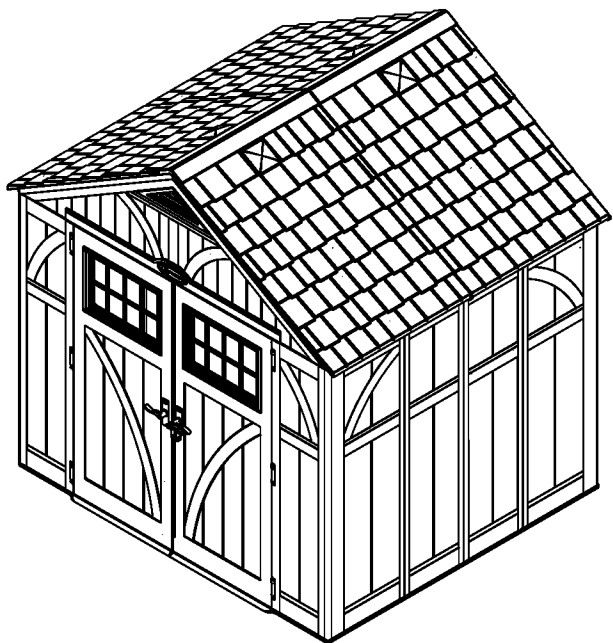

Suncast Products and Replacement Parts



To purchase Suncast replacement parts and learn about other Suncast products, visit www.suncast.com or call 1-800-846-2345 or 1-630-879-2050.



KEEP THESE INSTRUCTIONS. You will need Quality Control Number shown below to register your product.

Quality Control Number:

Assembled exterior dimensions 8' 4 1/2"W x 7' 1 3/4" x 8'7"H

Before You Begin...

- **Consult your local authorities for any permits required to construct shed.**
Prior to the construction of your shed, check with the local building code official to review any required permits or building limitations.
- **A level and sturdy foundation is required before shed construction can begin.**
Site preparation information is available on pages 11-12. A foundation that differs from the suggestions within this manual could prevent proper assembly and may damage parts.
- **Read instructions thoroughly prior to assembly.**
This kit contains parts that can be damaged if assembled incorrectly or in the wrong sequence.
- **Please follow instructions.**
Suncast is not responsible for replacing parts lost or damaged due to incorrect assembly.
- **Check for all parts before you begin assembly.**
Using the provided parts check list on pages 4-10, verify that you have all the parts required to construct your shed model. **COMPLETE SITE PREPARATION AND FOUNDATION CONSTRUCTION BEFORE UNPACKING ALL PARTS.**
- **Assistance is required during entire assembly.** 



CAUTION

- Proper site preparation required.
- Shed not intended for use in extreme weather conditions.
- Shed not intended for storage of flammable or caustic chemicals.
- Store heavy items near the bottom of shed.
- Shed not intended for use by children.
- **DO NOT** stand, sit, or store items on storage shed roof.
- Treat carefully in extreme temperatures.
- Repair or replace broken parts immediately.
- Suncast is not responsible for damage caused by weather or misuse.
- At regular intervals inspect your shed to make sure that assembly integrity has been maintained.
- Periodically check that the location you have chosen to set your shed is still level.
- This kit contains parts with metal edges. Please be careful when handling.

Shed Safety and Care

- Hot items, such as recently used grills, blowtorches, etc., must not be stored in the shed.
- Heavy articles should not be leaned against the walls, as this may cause panel distortion and permanent damage.
- Keep roof clean of snow and leaves.
- The shed walls and roof sections have a textured exterior, much like vinyl home siding. Over time, dust may accumulate in the texture. When combined with moisture, this could encourage the growth of moss or mold on the shed. To maintain the look of your shed, we recommend cleaning it each year with mild soap and water. **DO NOT** use bleach, ammonia, or other caustic cleaners, and **DO NOT** use stiff bristle brushes. Failure to perform annual cleaning could result in permanent staining of the plastic. This is not a manufacturing defect and is not covered under warranty.

Assembly Day Tips

- Complete site preparation and foundation construction before unpacking parts and beginning assembly.
- **DO NOT** attempt to assemble on a day with strong winds.
- **DO NOT** attempt to assemble on days when temperature is below 32 degrees.
- Set aside appropriate amount of time to completely assemble shed.
- Make sure you have assistance nearby to lift and secure parts in place.
- Wear light duty work gloves while assembling shed.
- Once roof is assembled, a flashlight may be of use when assembling smaller components inside shed.
- **DO NOT** use a torque wrench or hand drill to tighten provided Easy bolts. Use 010210410 Easy Bolt Easy Driver tool (provided) **ONLY**.
- Suncoast provides extra hardware for small fasteners for customer convenience. In some cases, there will be extra small fasteners once the assembly is complete.

Note: This product contains parts that are used in different orientations to construct the shed. Please take note of the orientation of the parts shown throughout this instruction manual. Failure to follow instructions could result in damage to parts. Suncoast is not responsible for replacing parts lost or damaged due to incorrect assembly.

Parts - BMS8700 Walls and Floors

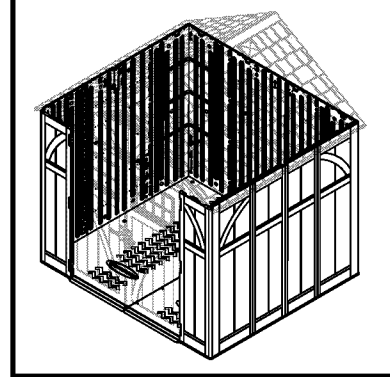

E

OB00165 –
Left front corner

S

OB00157 –
Shelf
x2

H

OB00171 –
Back

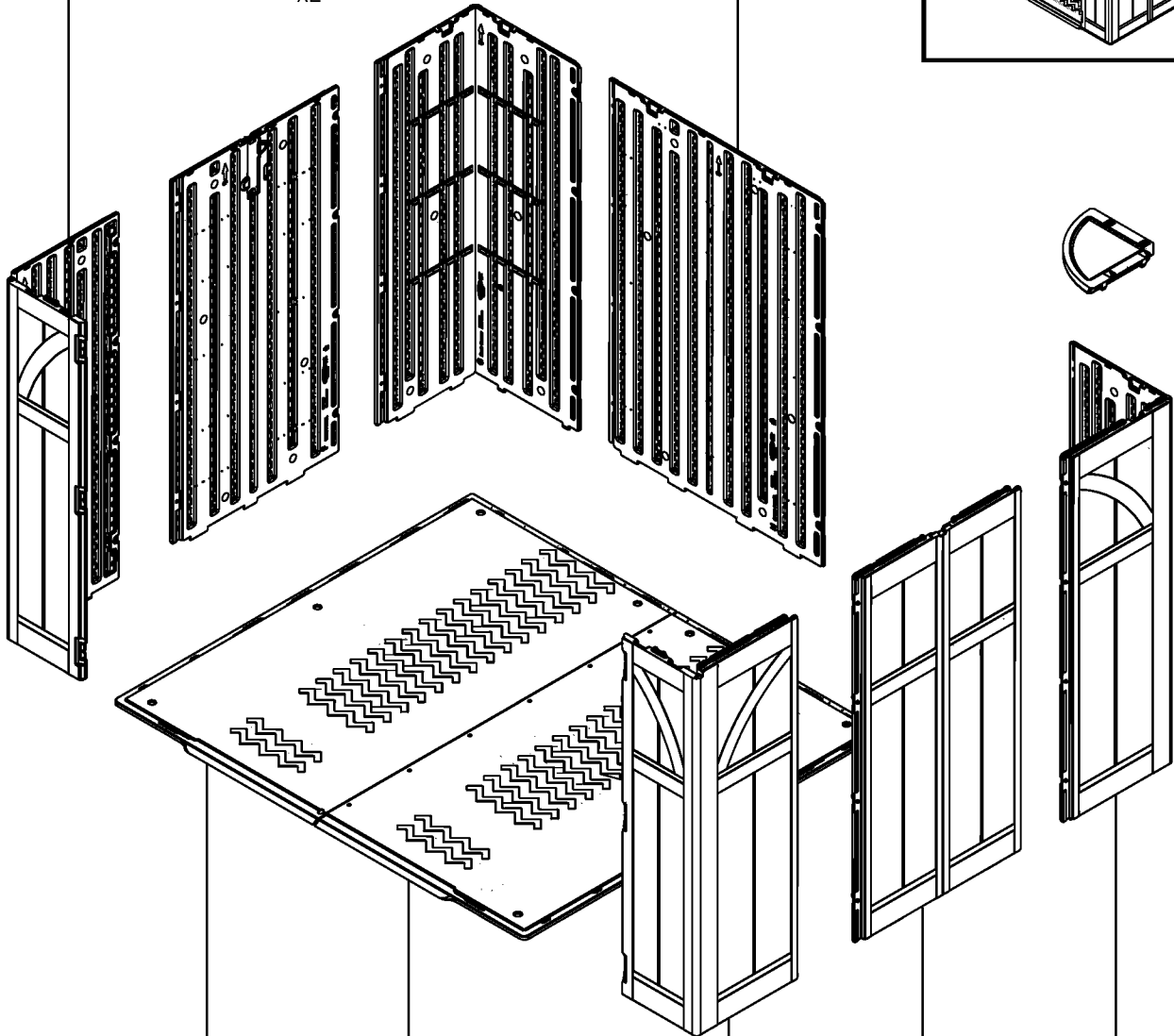

A

OB00173 –
Left floor

B

OB00174 –
Right floor

I

OB00166 –
Right front corner

F

OB00160 –
Side panel
x2

G

OB00156 –
Rear corner
x2

Parts - BMS8700 Doors

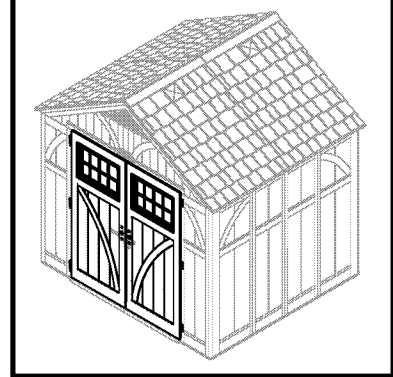

C

0440690 –
Door window
x1 set

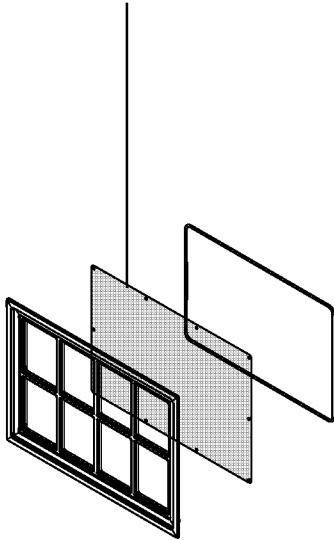

L

0B00163 –
Left door

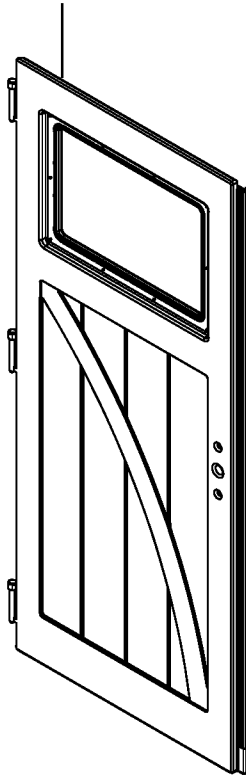

D

0440631 –
D-ring bolt
x1 set

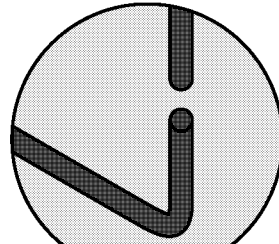
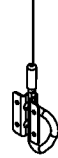

P

0102086 – Door
window frame
x2

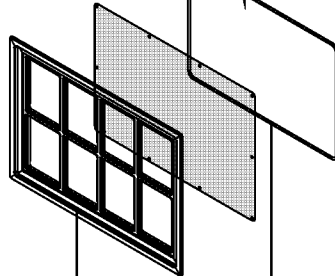

Q

0440655 – Door
window gasket
x1 set

M

0B00162 –
Right door

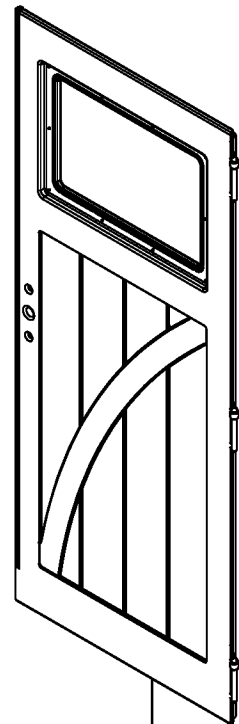

Parts - BMS8700 Headers

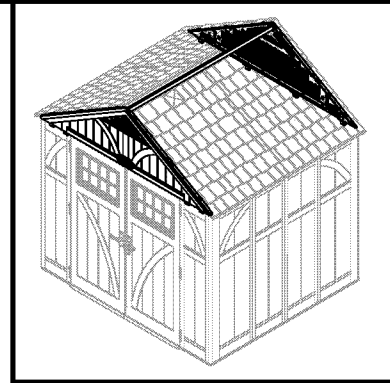

R

0280406 – Ridge beam

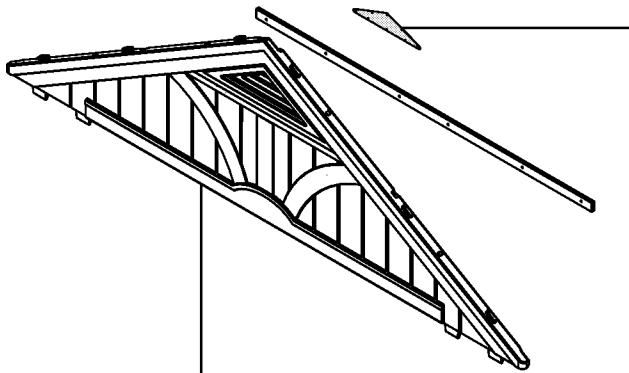
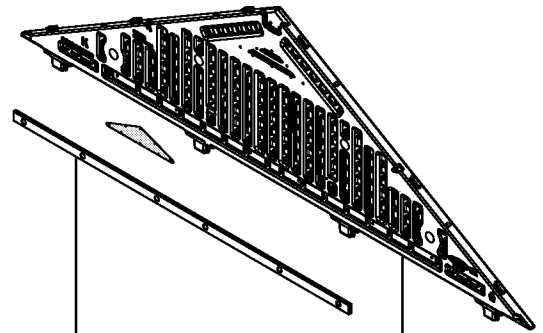
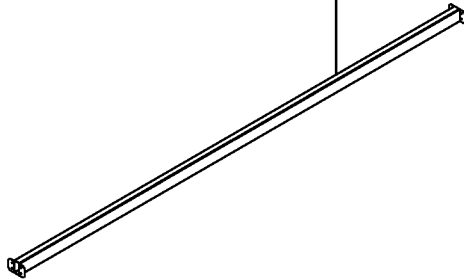

J

0B00159 –
Front header

YY

0440630 – Vent screen
x1 set

T

0280372A –
Header beam
x2

K

0B00161 –
Rear header

Parts - BMS8700 Truss

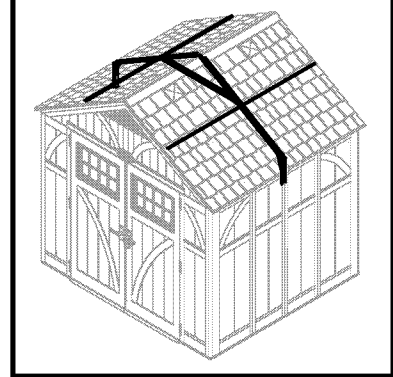

U

0631094 –
Truss leg
x2



V

0631096 –
Truss bracket



W

0440694 – Roof
support bracket
x1 set

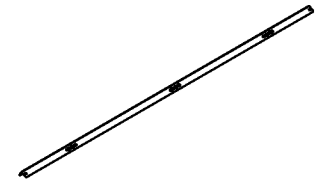
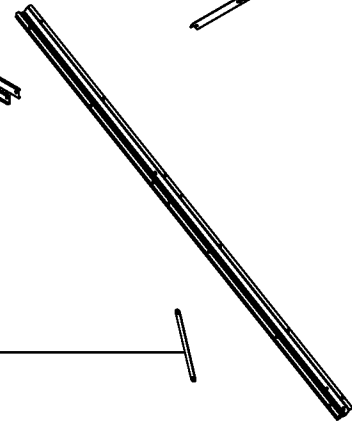
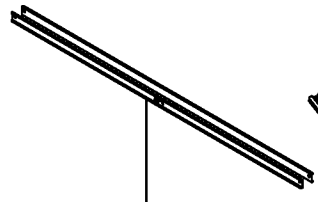
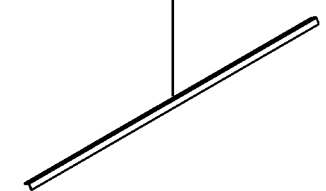

X

0631095 – Truss
cross beam
x2

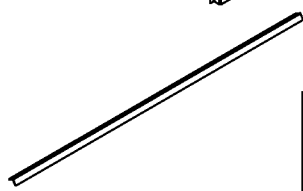

Y

0631093 – Truss strap
x2

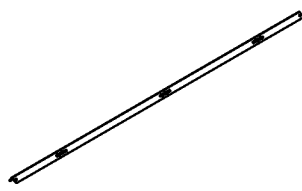

Z

0630817A – Side
adaptor bracket
x2



Parts - BMS8700 Roof

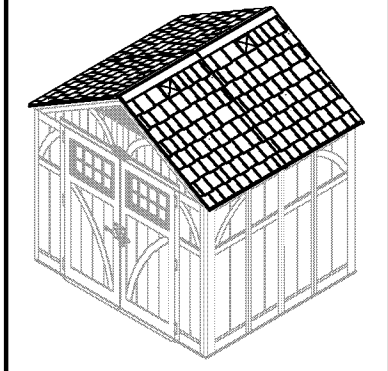

N

0B00167 –
Left roof
x2

AA

010223107 –
Skylight
x4

BB

0440691 –
Skylight sealing gasket
x2 sets

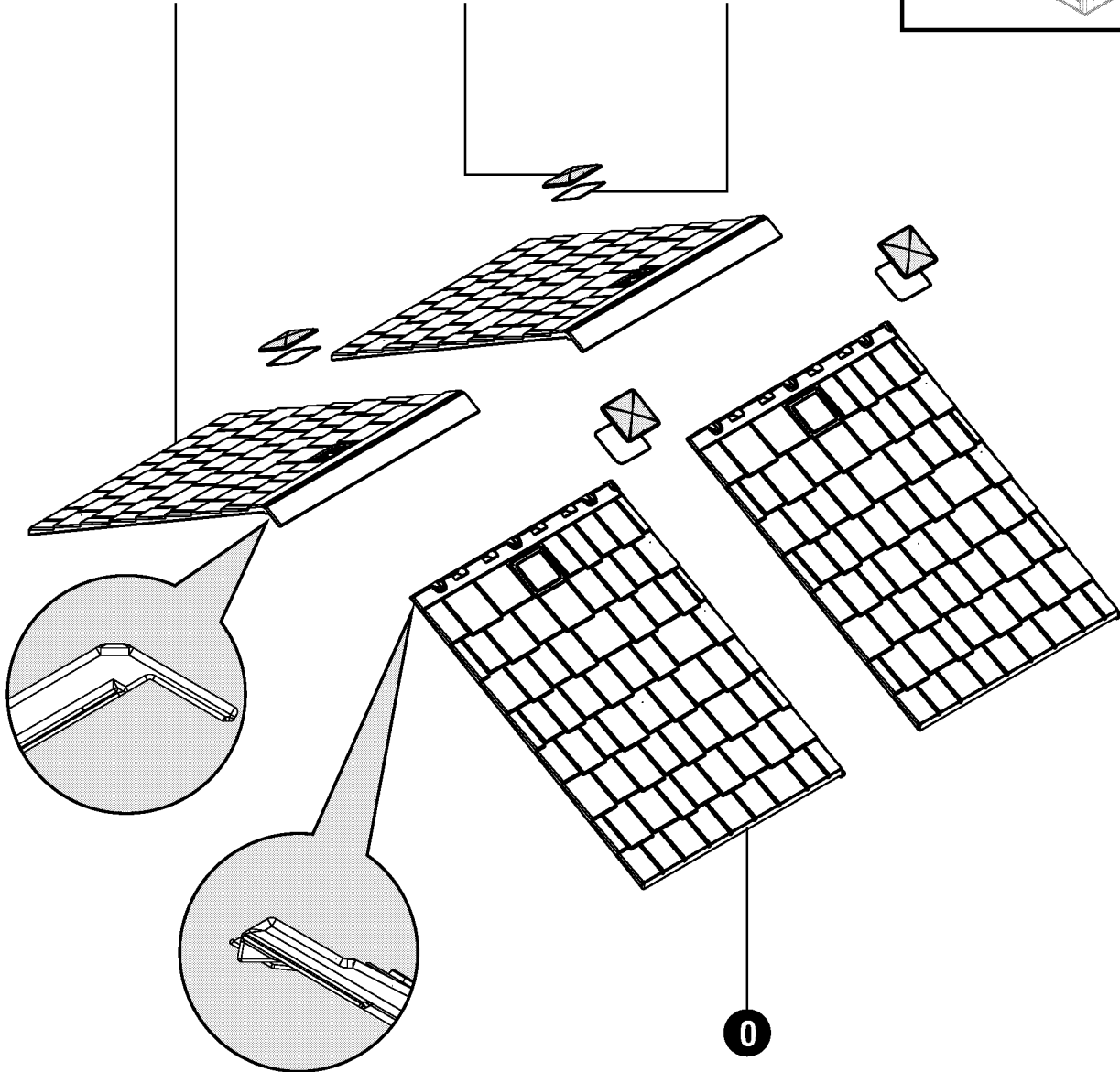

O

0B00168 –
Right roof
x2

Hardware - BMS8700

0440652

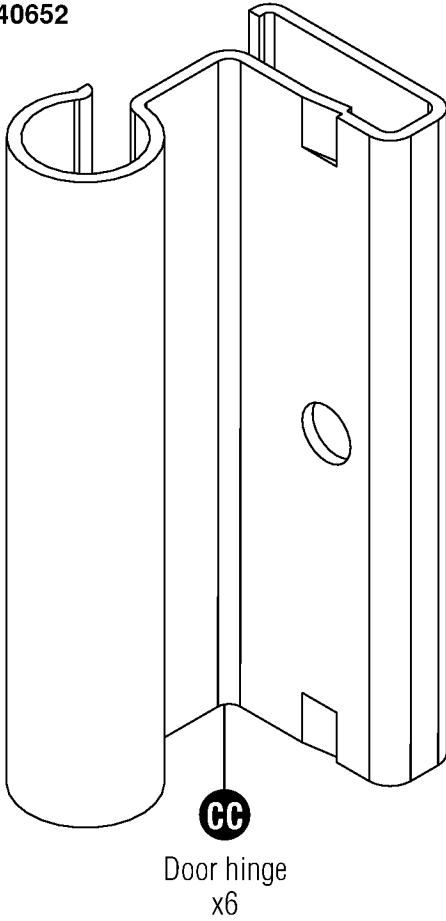

0480290 –
Hardware bag

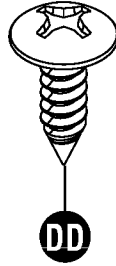

.625" Truss head screw
x75

0480305 –
Hardware bag

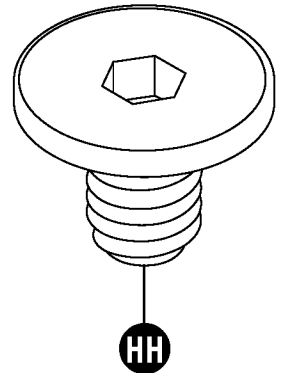

Easy bolt 7/8"
x28

0480336 –
Hardware bag

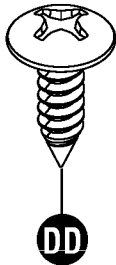

.625" Truss head screw
x125

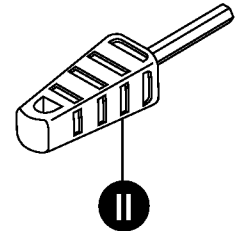

*Easy bolt easy driver

0480337 – Hardware bag

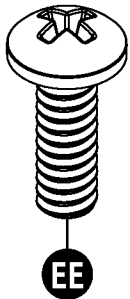

.25" x .75"
Phillips machine screw
x6

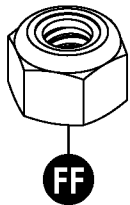

.25" Locking nut
x6

0480342 – Hardware bag

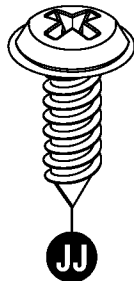

.75" Sealing screw
x6

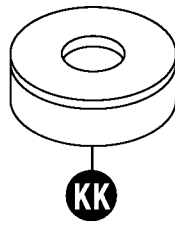

Rubber washer
x6

0480340 – Hardware bag

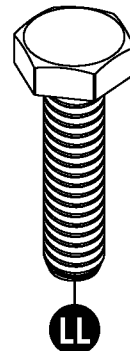

.25" x 1" Hex bolt
x2

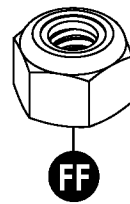

.25" Locking nut
x6

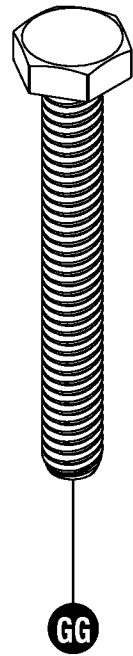

.25" x 2" Hex bolt
4

Hardware shown at actual size (*Unless otherwise noted.) Extra hardware provided. Not all are used.

Door Handle Kit - BMS8700

0440647A – Door Handle Kit

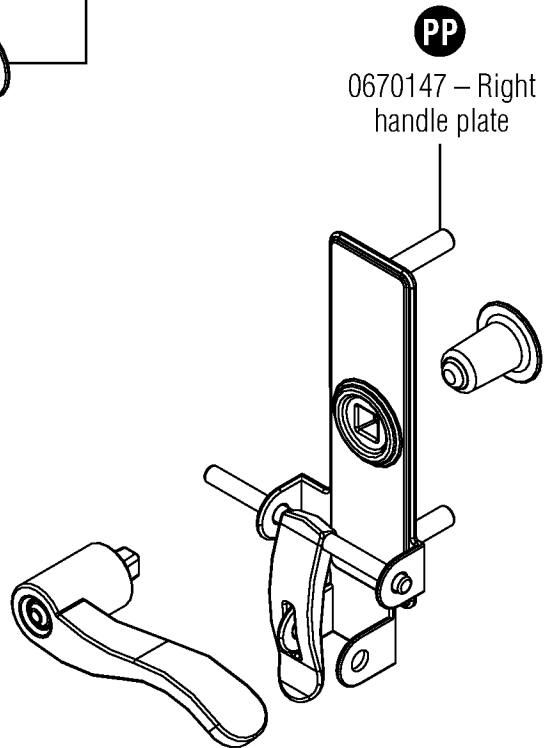
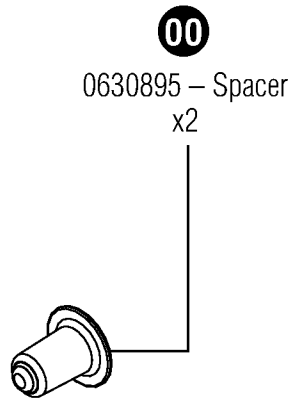
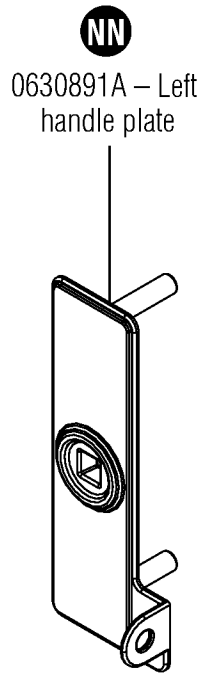
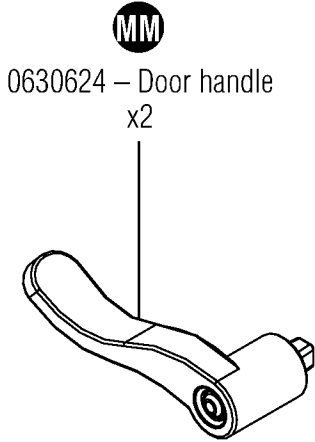
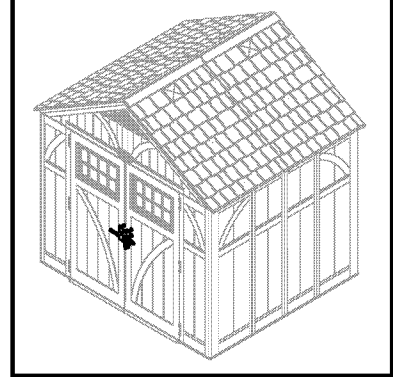

Hardware

0480306B – Hardware bag

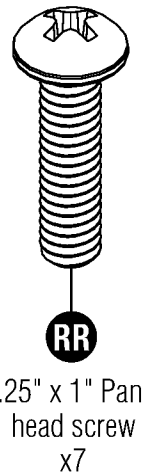
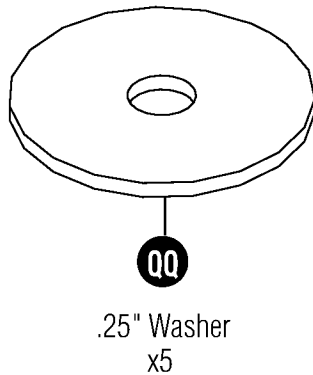

Hardware shown at actual size (*Unless otherwise noted.) Extra hardware provided. Not all are used.

Site Preparation and Platform Construction

Materials **NOT** supplied with BMS8700 Shed Kit

Note: Site preparation is required for this shed. Placing the shed on a constructed foundation is highly recommended. Without a constructed foundation, settling will probably occur, causing distortion and damage to the shed. Suncoast is not responsible for replacing parts damaged or property lost due to incorrect assembly.

Note: Complete the site preparation and foundation construction before unpacking parts and beginning assembly.

To prepare your shed site, follow the steps below:

- 1) Consult your local authorities for building codes and covenants before beginning foundation or erecting shed.
- 2) Before any digging, check with local utilities to determine location of buried cables, pipes, etc.
- 3) Decide which type of foundation you want:
 - Concrete slab, 4" thick

OR

- Wood platform

Use exterior grade wood. The wood platform should be set on pier blocks or footing. Consult your local retailer for help to determine the best anchoring method for your particular installation. The provided plans are sized for the minimum number of cuts to lumber and plywood.

- 4) Prepare the building site:
 - The ground should slope away from the foundation area to provide drainage.
 - The foundation surface must be flat and level.
 - A vapor barrier should be provided to prevent excessive condensation in the shed.
 - Follow local building codes for a proper vapor barrier.
- 5) Anchoring the shed to the foundation:
 - Consult your local retailer for help to determine the best anchoring method for your particular installation.
 - To secure the shed to a concrete slab, use masonry fasteners available at your local hardware retailer.
 - To secure the shed to a wood platform, use 1/4" x 2" long lag screws with washers.

Anchoring floor panel to concrete slab

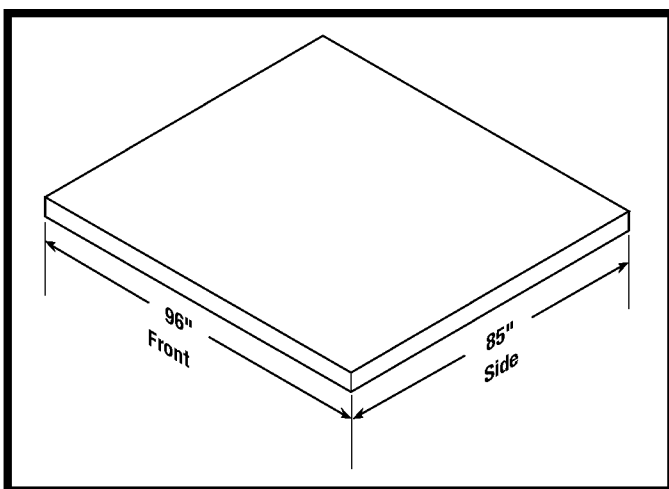

- Secure shed to concrete slab using masonry fasteners.
- Dimensions allow for shed to fit within the nearest 1" on each side.

Anchoring floor panel to wood platform

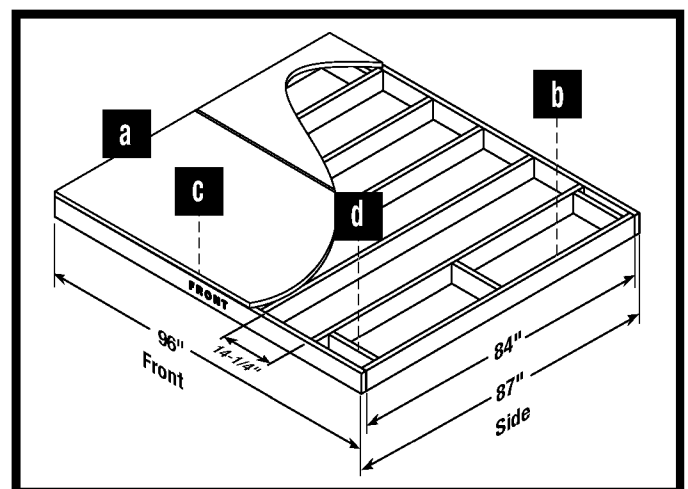

- Secure shed to wood platform using 1/4" x 2" lag screws.

Site Preparation and Platform Construction (continued)

Materials **NOT** supplied with BMS8700 Shed Kit

Wood platform critical spacing

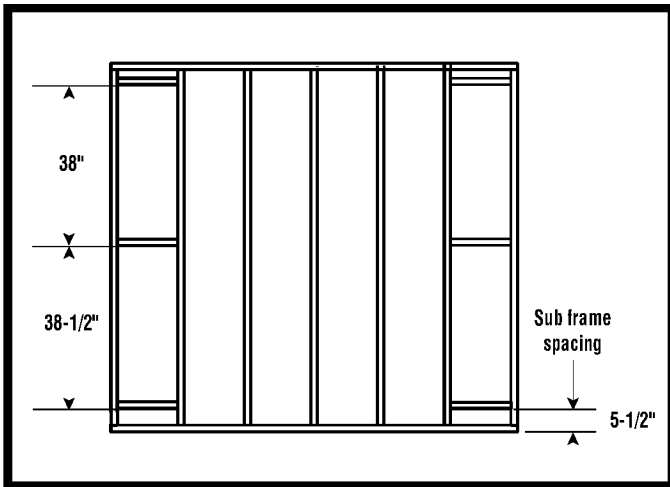

- Check all critical spacing measurements.

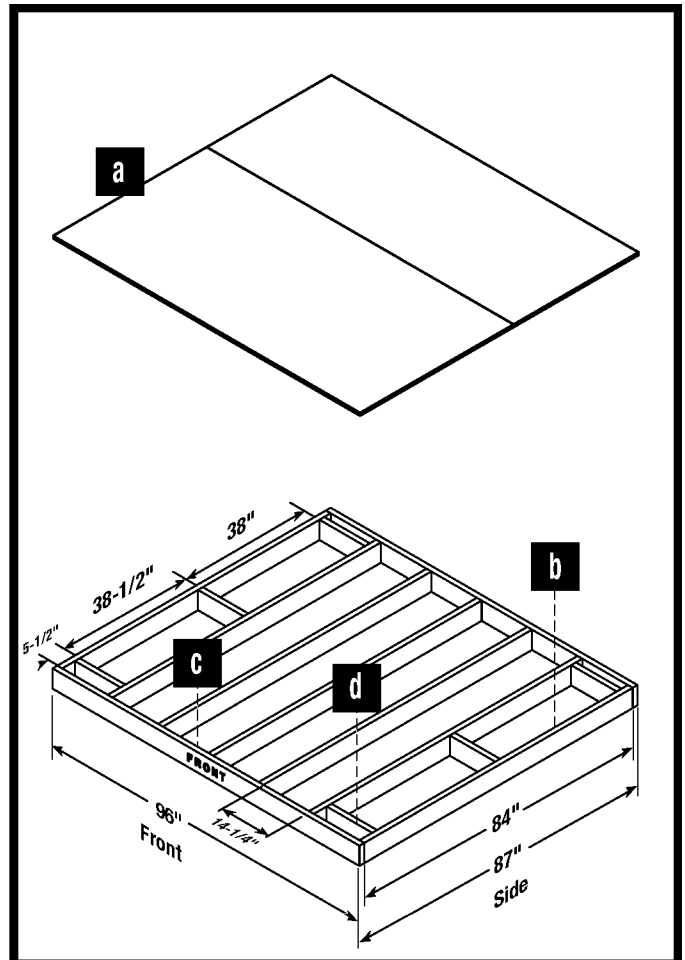

Wood platform materials list

Item	Qty	Size
a	2	48" x 96" x 3/4"
b	7	2" x 6" x 84"
c	2	2" x 6" x 96"
d	6	2" x 6" x 14-1/4"

Door Pre-Assembly

Parts/hardware needed for door pre-assembly are shown on pages 5 and 9.

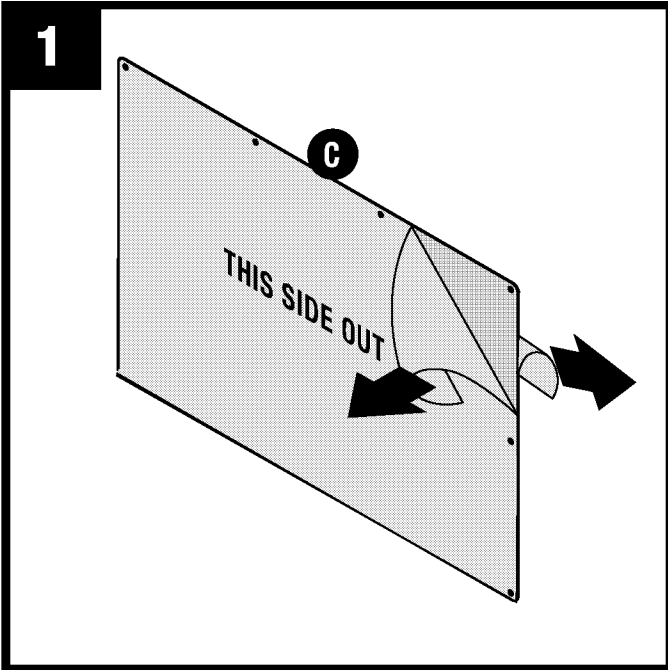

Peel film from both sides of window (C). Remove protective film from door edges.

Note: One side of film will say "THIS SIDE OUT." Make sure this side faces out when installing window.

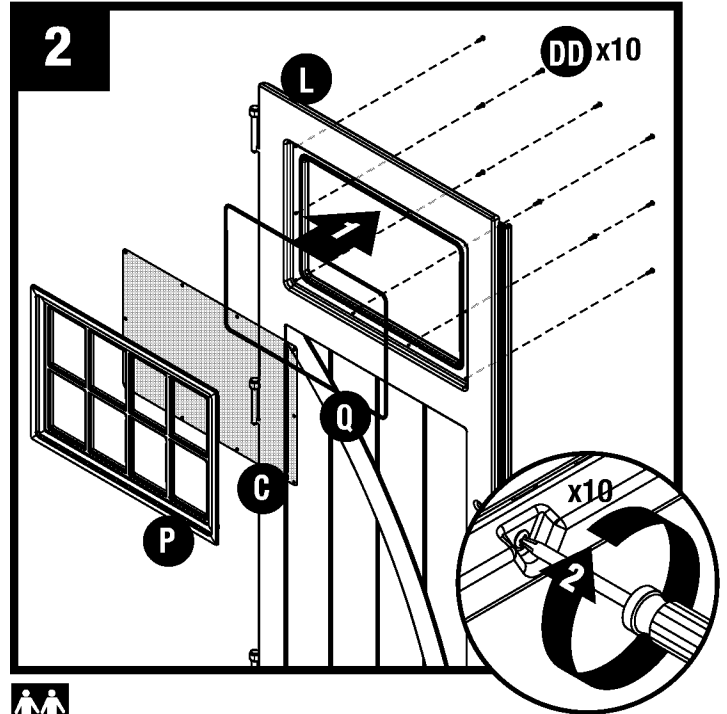

Place gasket (Q), window (C), and frame (P) into door channel. Secure with ten screws (DD), starting at corners. **DO NOT** over tighten screws.

Note: The cut portion of gasket (Q) **MUST** be assembled on bottom of door channel.

Repeat for right door (M).

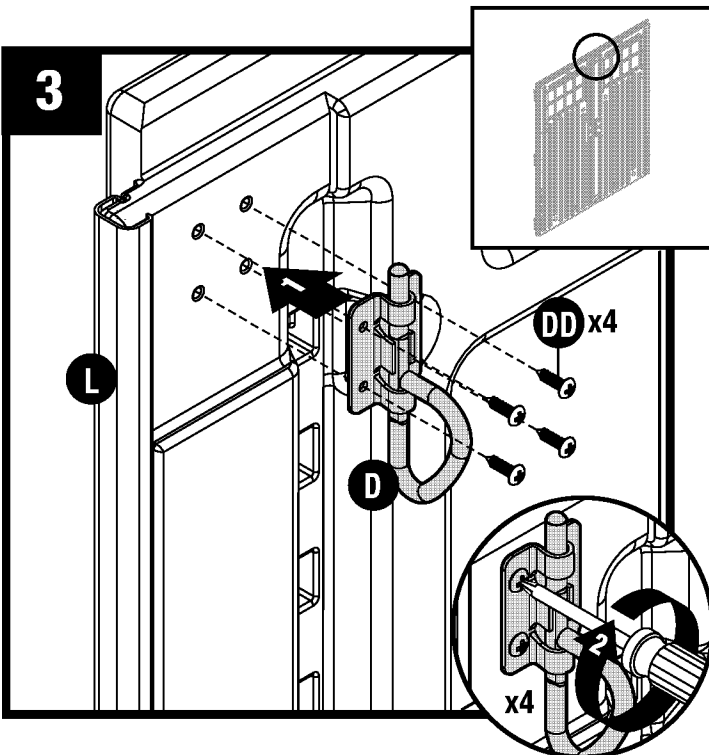

At top interior side of left door (L), attach D-ring slide bolt (D) with four screws (DD).

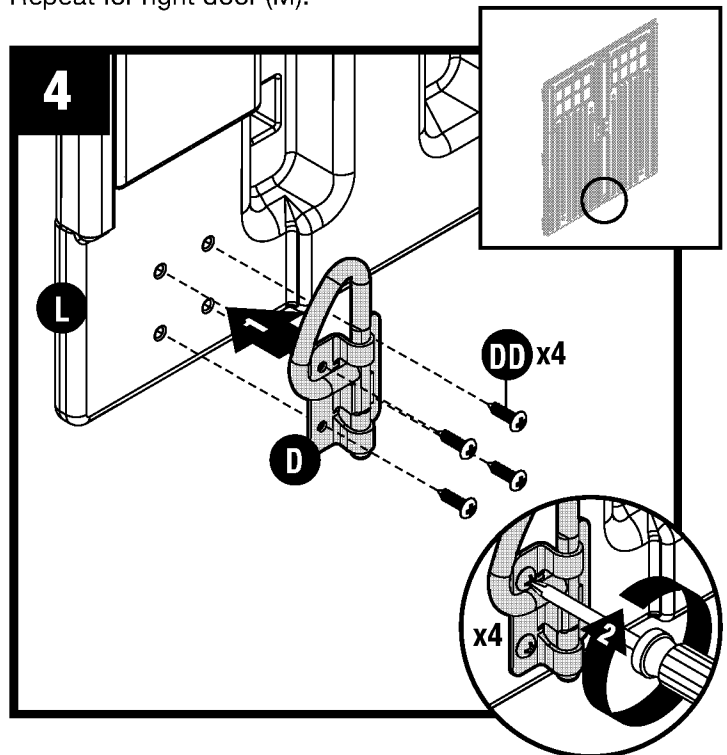

At bottom interior side of left door (L), attach D-ring slide bolt (D) with four screws (DD).

Header Pre-Assembly

Parts/hardware needed for header pre-assembly are shown on pages 6 and 9.

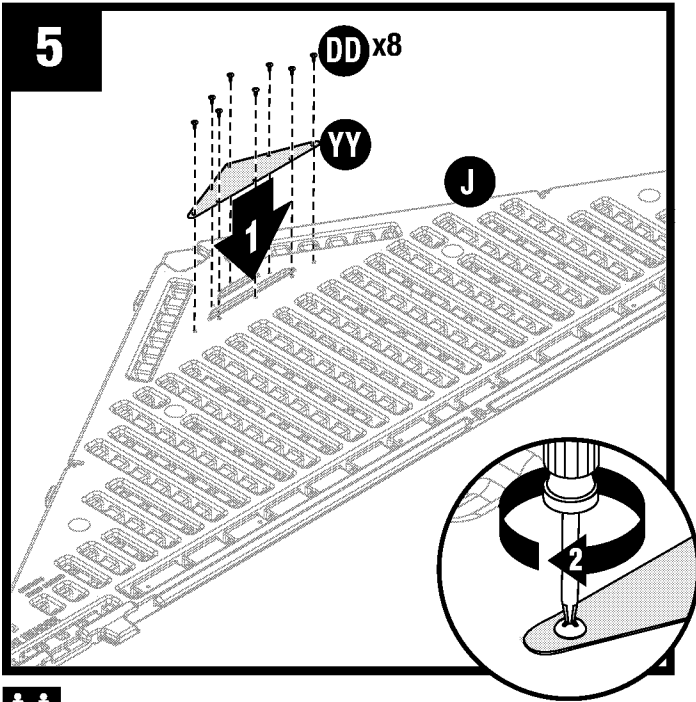

Lay front header (J) on ground with lettering side facing up. Place fiberglass vent screen (S) into rear opening in front header (J). Secure with eight screws (DD). **DO NOT** over tighten screws.

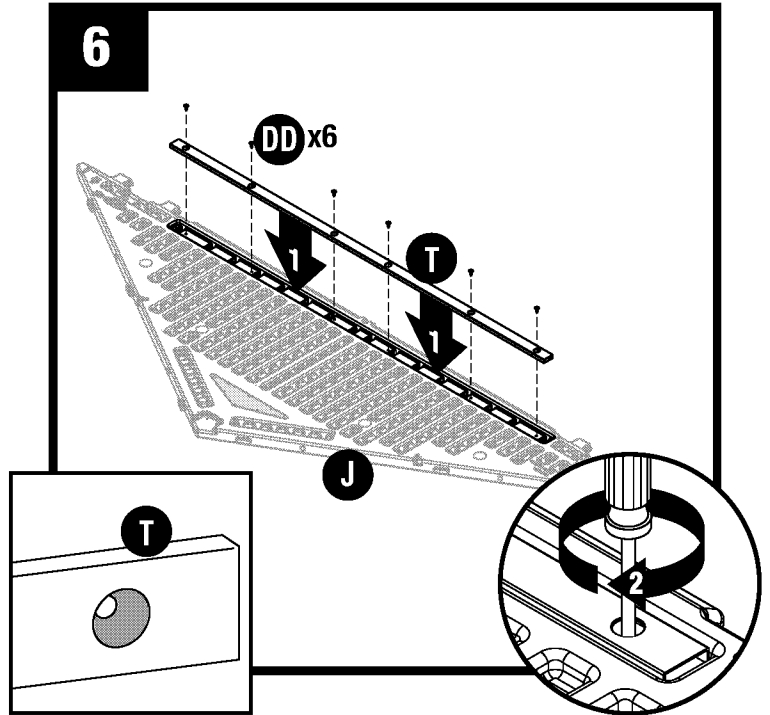

Place header beam (T) into pocket of front header (J). Secure with six screws (DD). **DO NOT** over tighten screws.

Repeat Steps 5-6 for rear header (K).

Note: Header beam (T) has large holes on one side and small holes on other side. The small holes must face header.

Roof and Truss Pre-Assembly

Parts/hardware needed for roof and truss pre-assembly are shown on pages 7, 8, and 9.

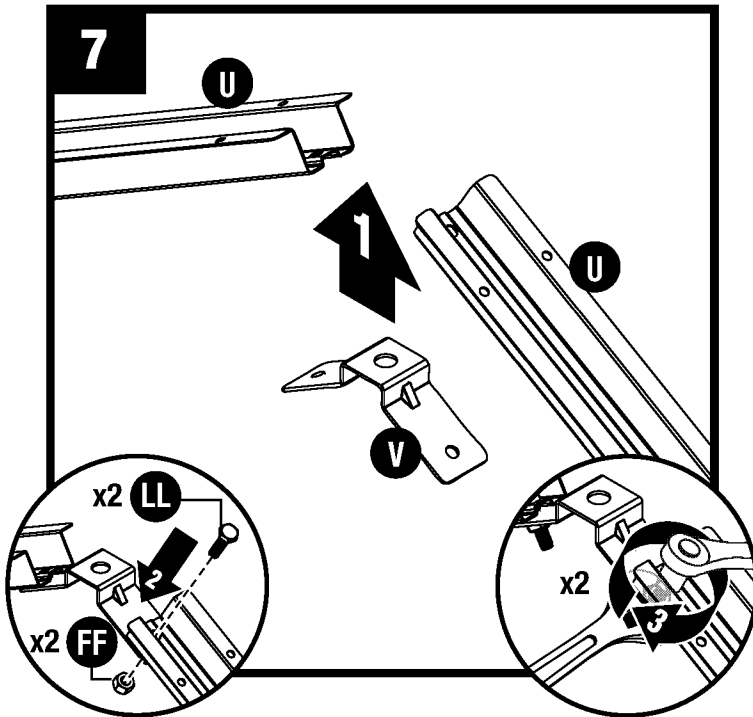

Attach truss bracket (V) to end of one truss leg (U) with one hex bolt (LL) and one nut (FF).

Repeat for second truss leg (U).

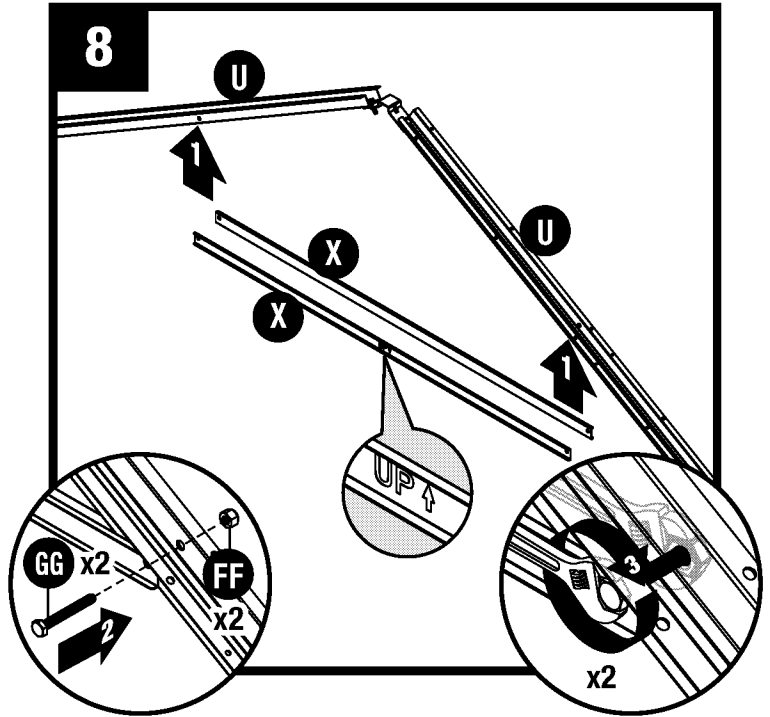

Attach two truss cross beams (X) to two truss legs (U) with two hex bolts (GG) and two nuts (FF). Stand truss and check cross beam is level.

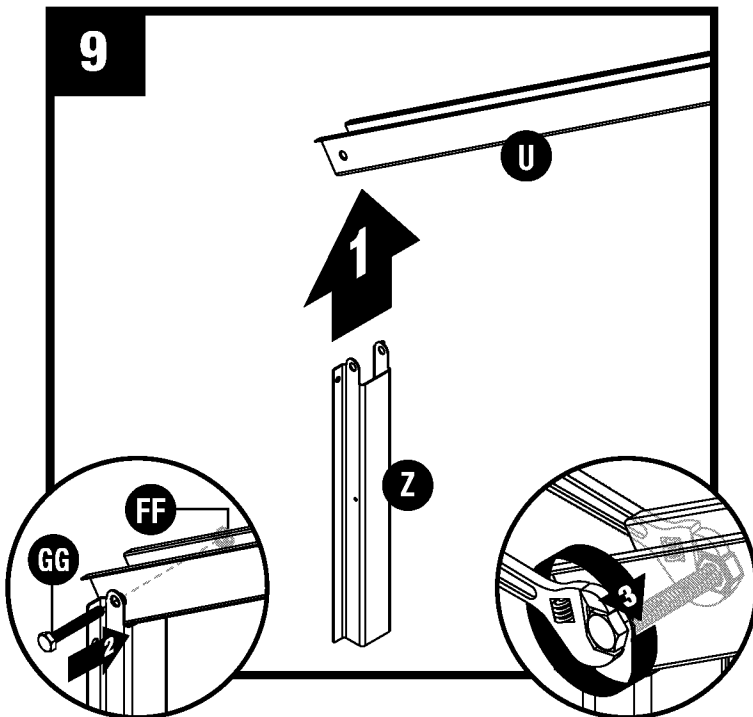

Attach side adaptor bracket (Z) at end of left truss leg (U) with one hex bolt (GG) and one nut (FF).

Repeat for remaining side adaptor bracket (Z).

Note: DO NOT over tighten. This makes roof assembly difficult.

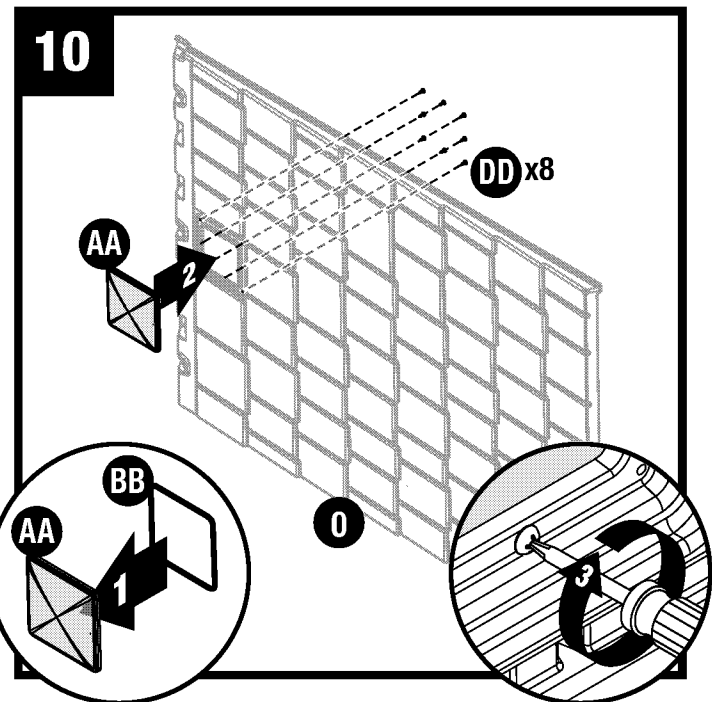

Place skylight gasket (BB) into skylight (AA). Place skylight (AA) onto right roof panel (O). Secure from underside with eight screws (DD). Make sure rib on plastic parts is seated fully against gasket on skylight.

Repeat for remaining roof panels.

Shed Assembly/Walls

Parts/hardware needed for wall assembly are shown on pages 4 and 9.

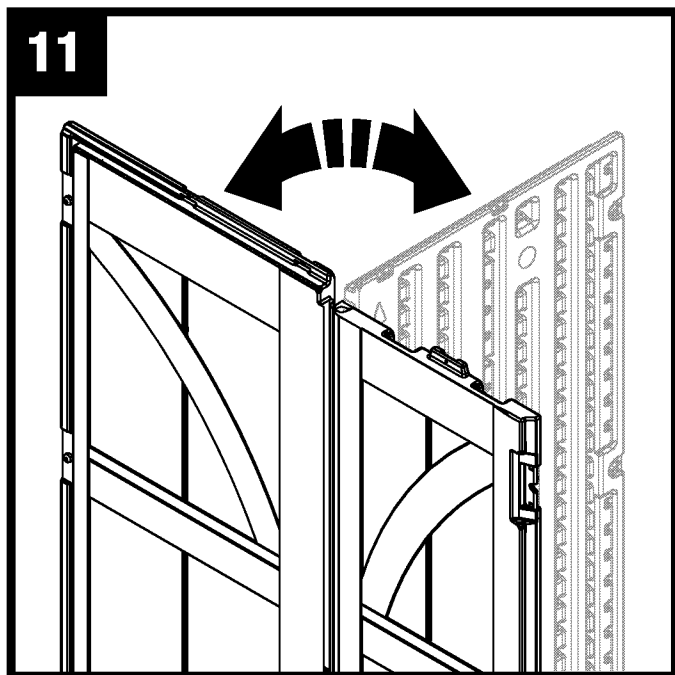

Critical: When installing corners, flex corner hinges back and forth several times. This will help provide a square corner and ensure proper fit of remaining panels.

Important: DO NOT flex in reverse position, as this can crack the panel.

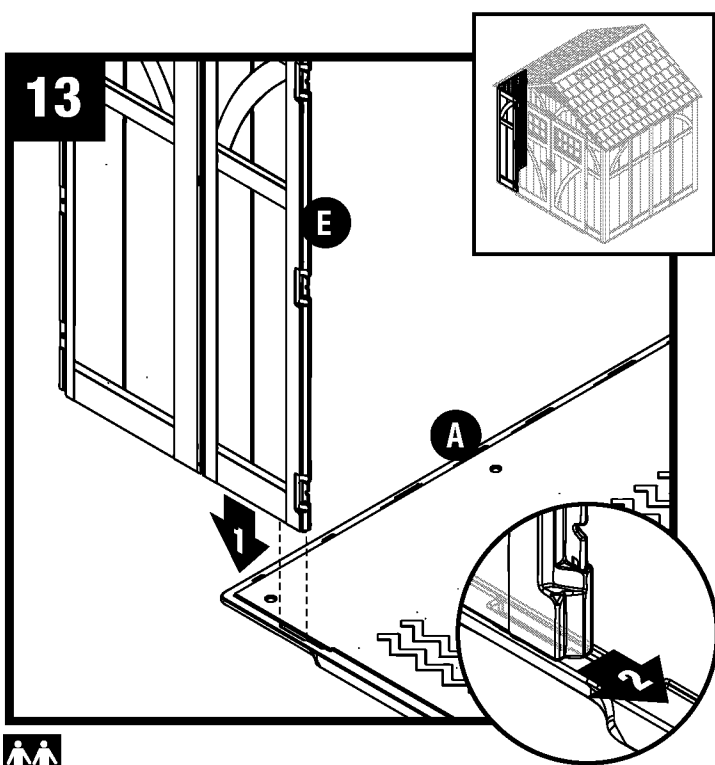
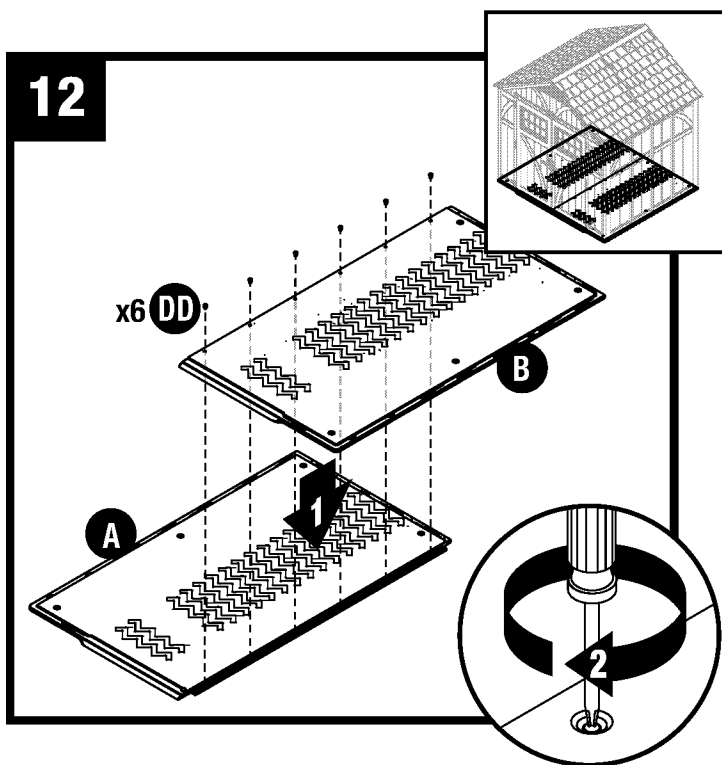

Push left floor (A) and right floor (B) panels together and secure with six screws (DD).

Note: Refer to pages 11 and 12 to secure floors to foundation.



Align tab on bottom of left front corner (E) with slot on left floor (A). Lower panel into slot and lock in place by sliding panel toward door opening.



Note: Use a rubber mallet to “push” left front corner (E) into locked position.

Shed Assembly/Walls (continued)

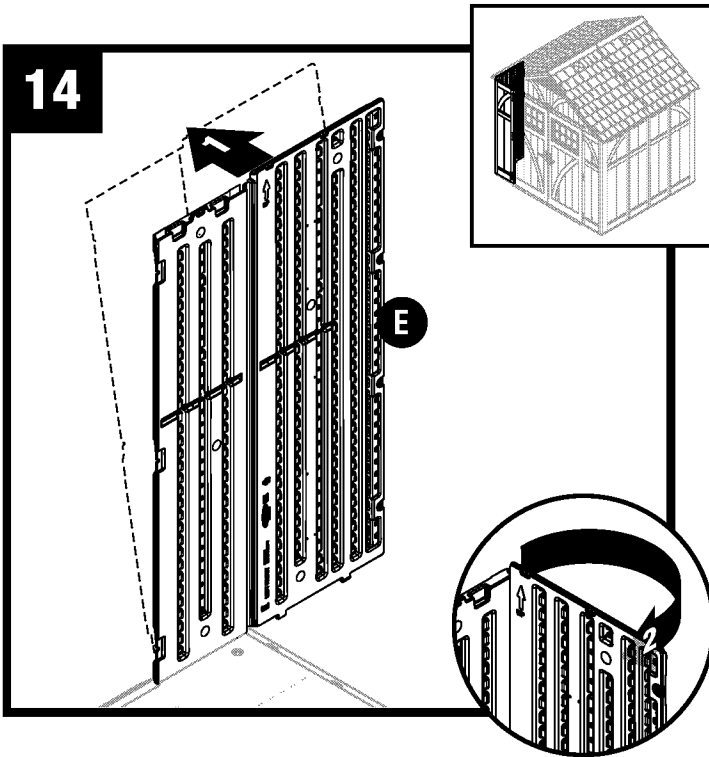

Tip left front corner (E) outward slightly and bend corner hinge.

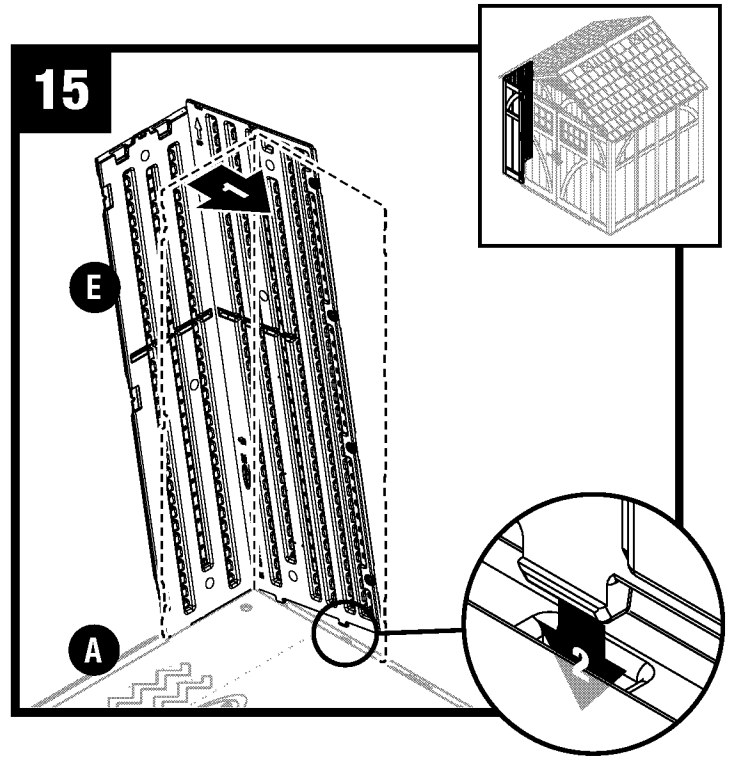

Tip left front corner (E) back to vertical position and align lower tabs on right side with slots in floor (A).

Note: You will hear a snap when tab is fully engaged.

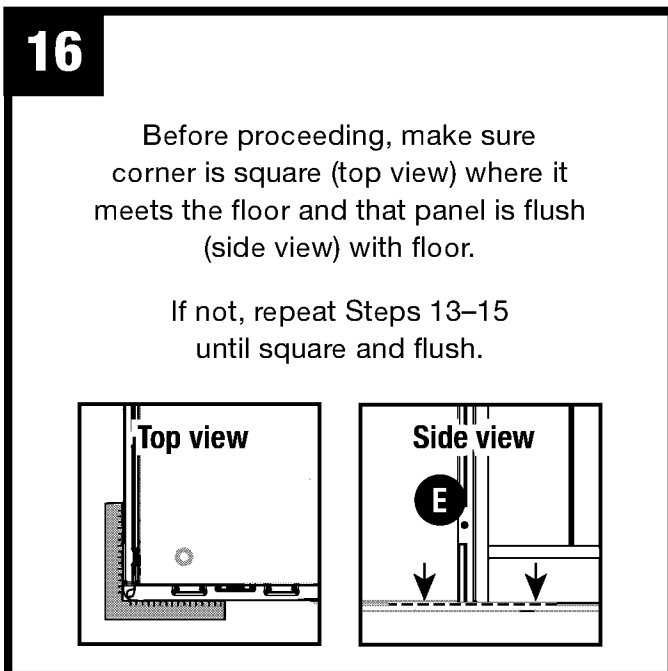

Shed Assembly/Walls (continued)

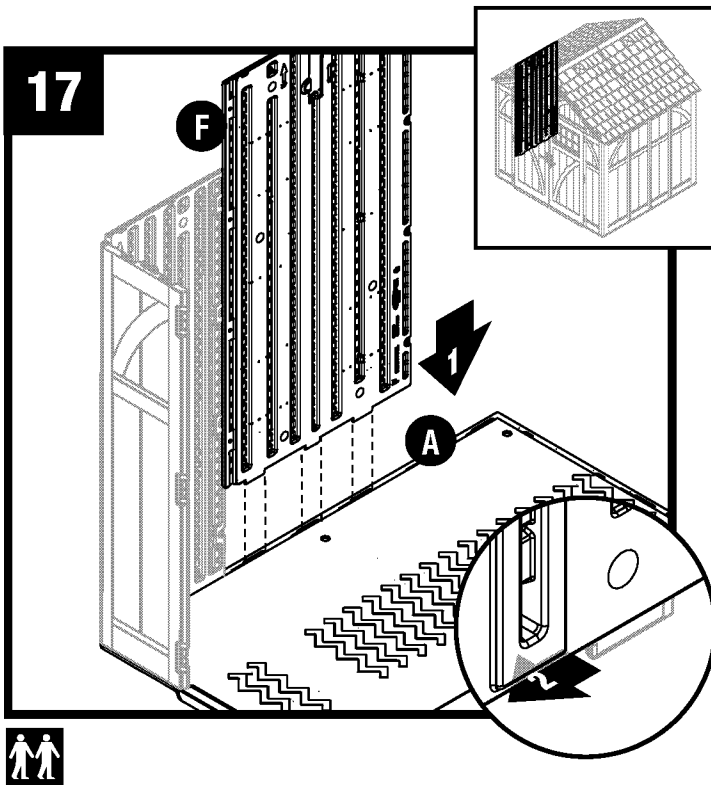

Align tabs on bottom of side panel (F) with slots along floor (A). Lower panel into slots and lock in place by sliding panel toward front corner.

 **Note:** Use a rubber mallet to “push” side panel (F) into locked position.

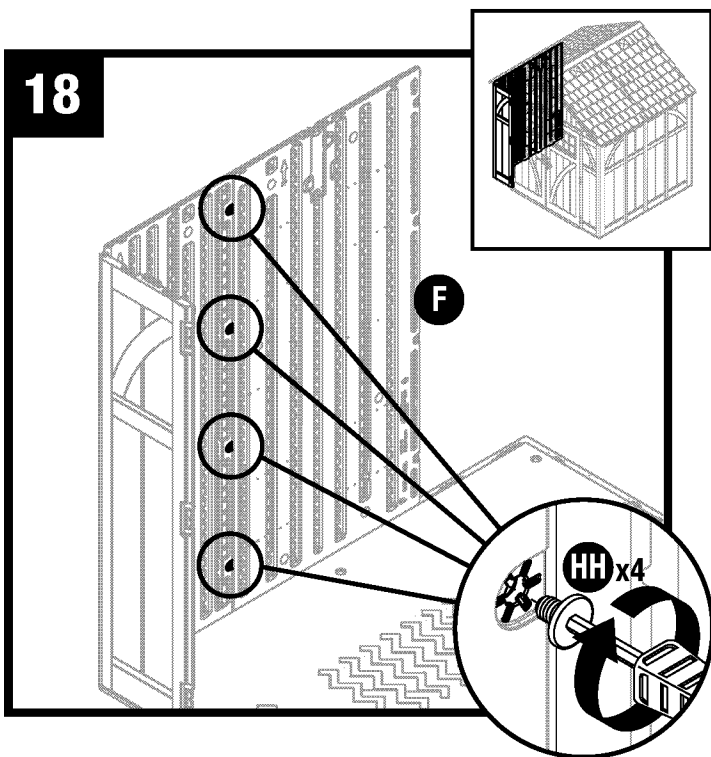

Secure side panel (F) with four easy bolts (HH), working from floor to roof. **DO NOT** use torque wrench. Use easy bolt easy driver (II) and hand tighten. Easy bolt head will be flush when fully seated. **DO NOT** over tighten easy bolts.

Note: You may hear a click when easy bolt has been tightened completely.

Shed Assembly/Walls (continued)

19

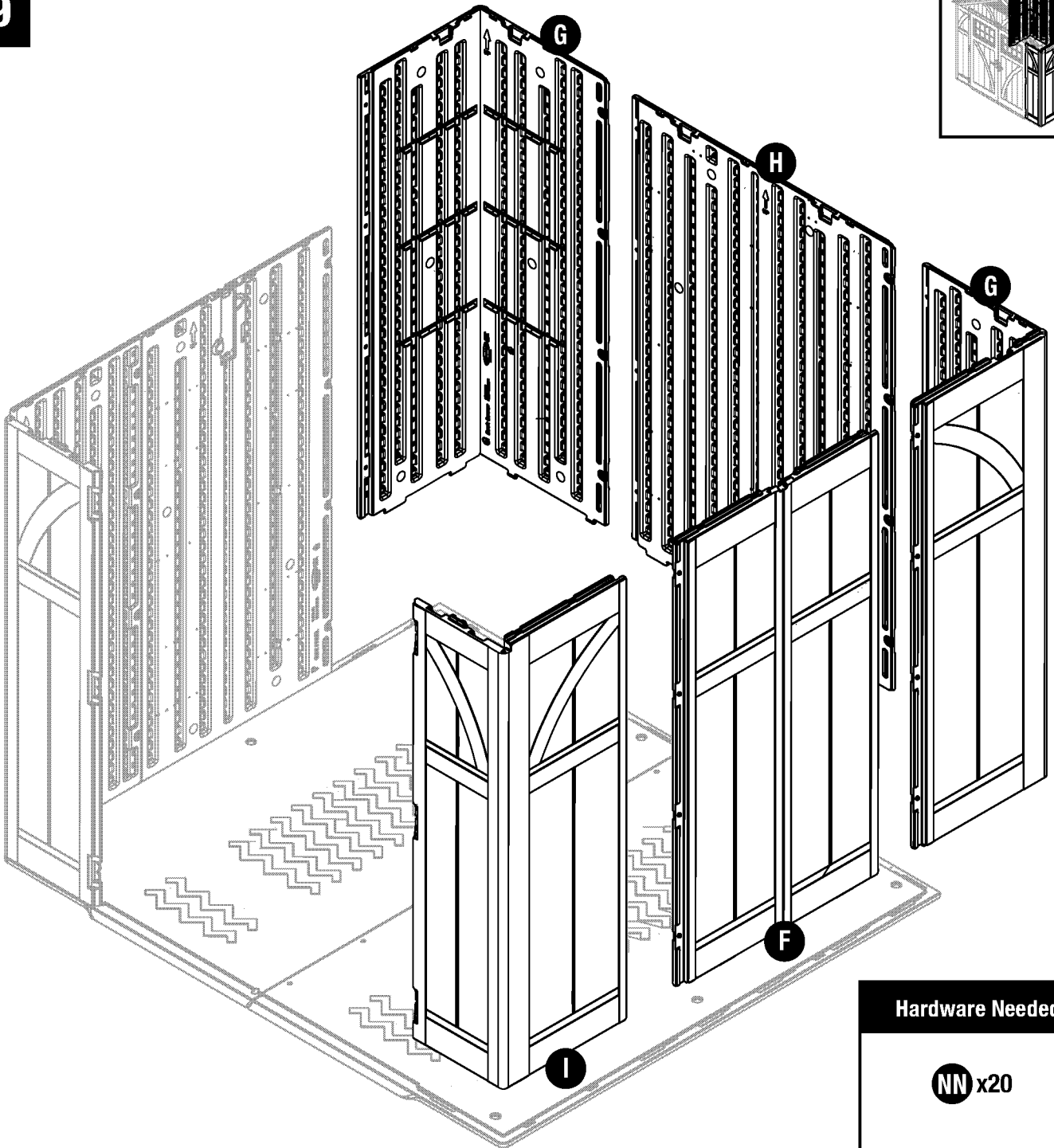
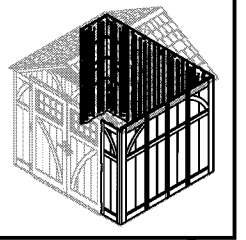

Hardware Needed

NN x20

Repeat Steps 13-18 for remaining panels.

Shed Assembly/Headers and Truss

Parts/hardware needed for headers and truss assembly are shown on pages 6, 7, and 9.

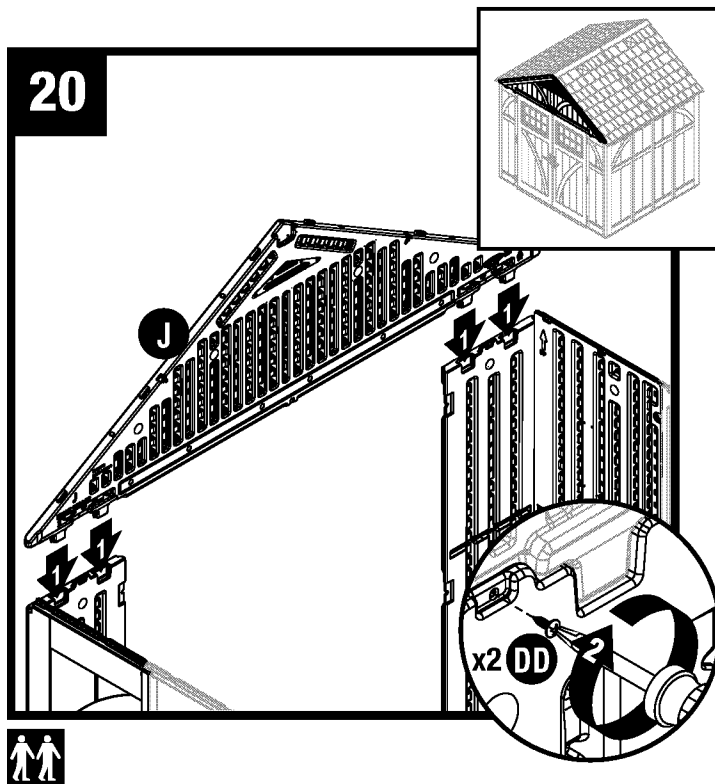

Place front header (J) over door opening and fit four protruding support legs into pockets molded in front corners. Secure front header using two screws (DD).

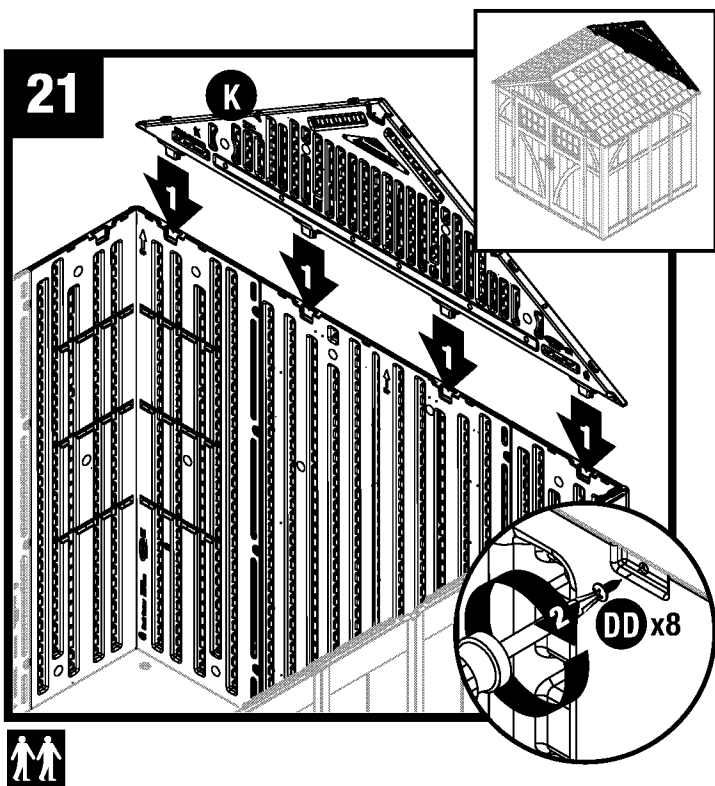

Place rear header (K) over back walls and fit four protruding support legs into pockets molded in back walls. Secure rear header using eight screws (DD).

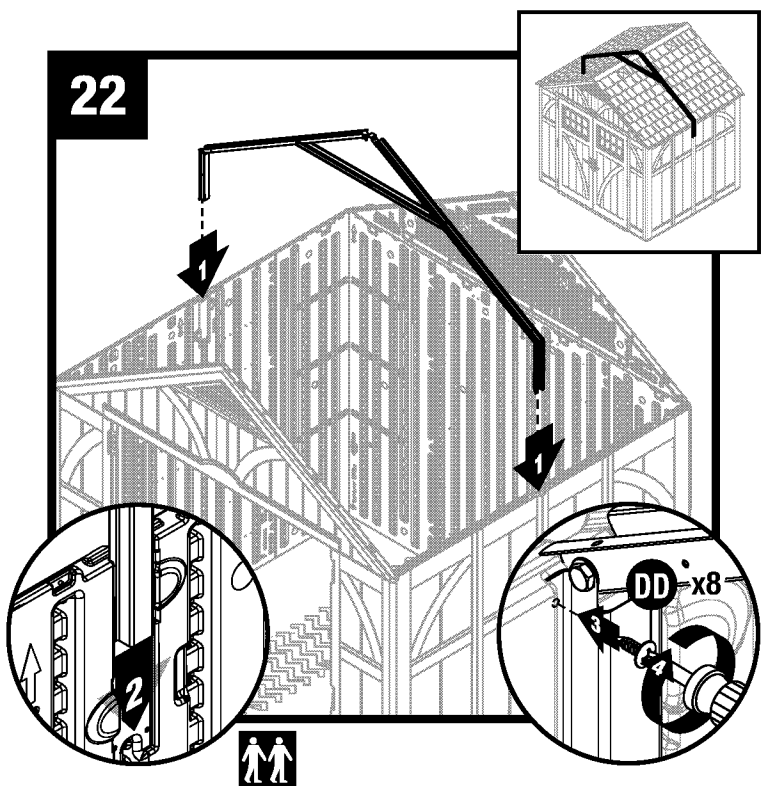

Slide truss assembly into place. Secure with four screws (DD) in each side adaptor bracket.

Shed Assembly/Headers and Truss (continued)

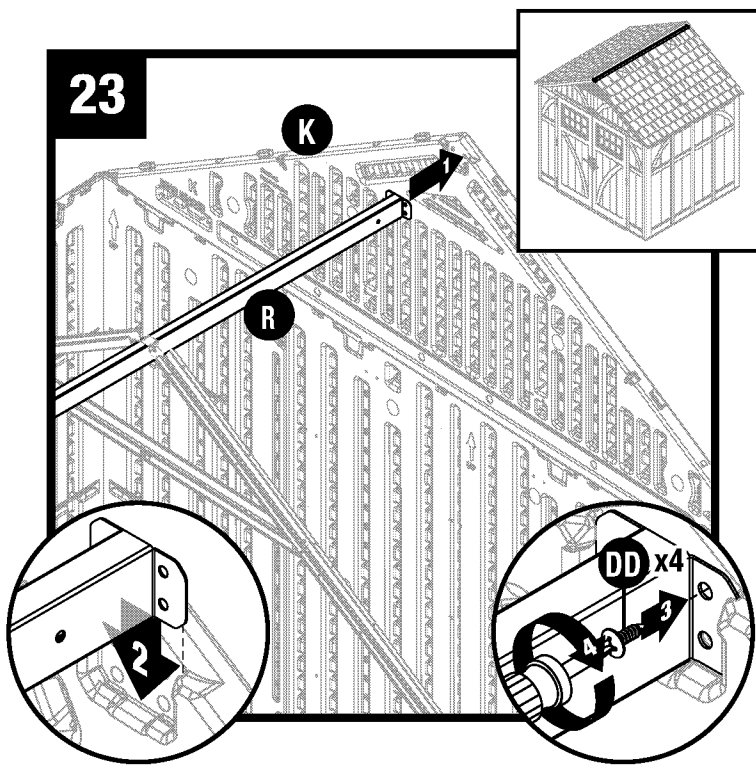

Raise ridge beam (R) up and into rear header (K). Secure with four screws (DD).

Repeat for front header (J).

Note: Header panels may need to be pushed inwards or outwards slightly as ridge beam is slid into place.

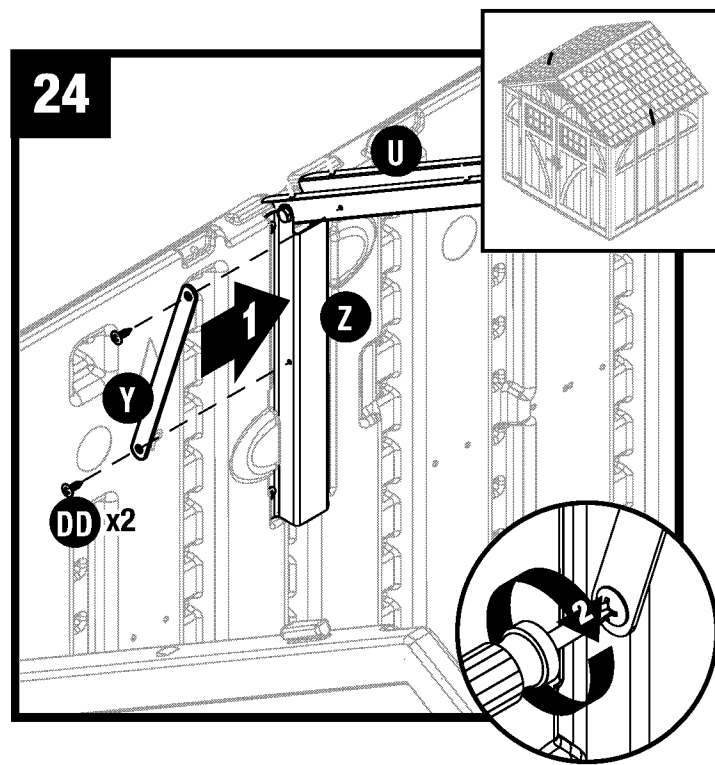

Attach truss strap (Y) to side adaptor bracket (Z) and truss leg (U) with two screws (DD).

Repeat for remaining truss straps.

Shed Assembly/Roof

Parts/hardware needed for roof assembly are shown on pages 8 and 9.

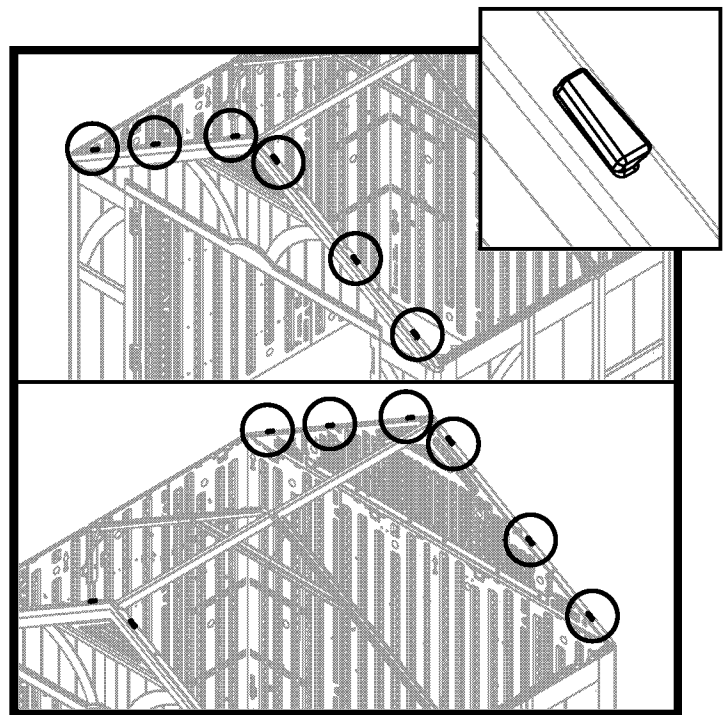
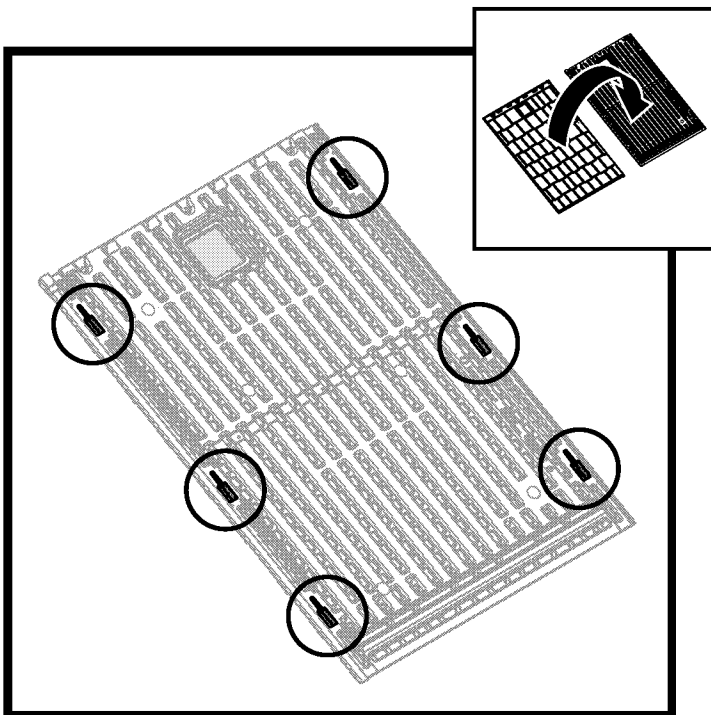

Before proceeding, locate and identify the six slots on interior side of right and left roof panels.

Before proceeding, locate and identify six front header tabs and six rear header tabs.

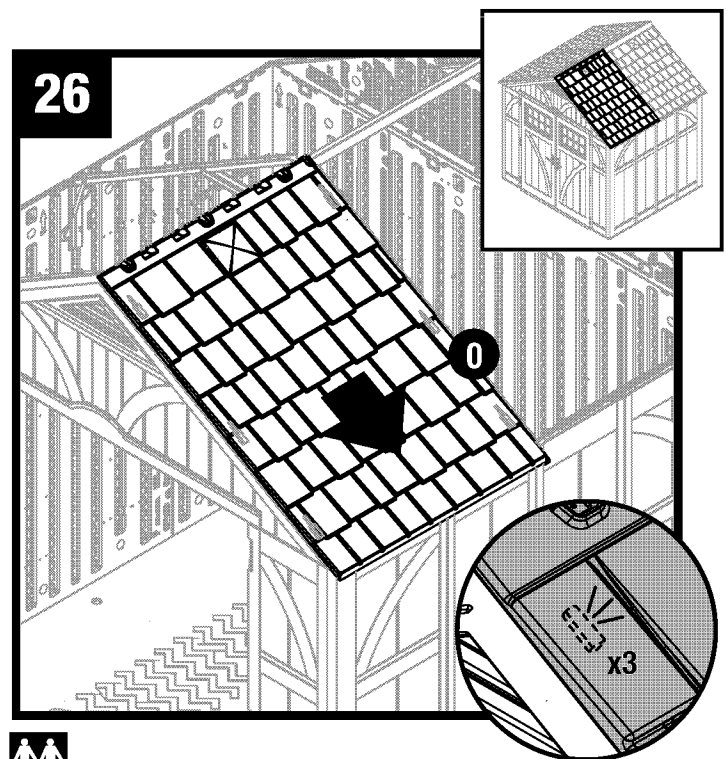
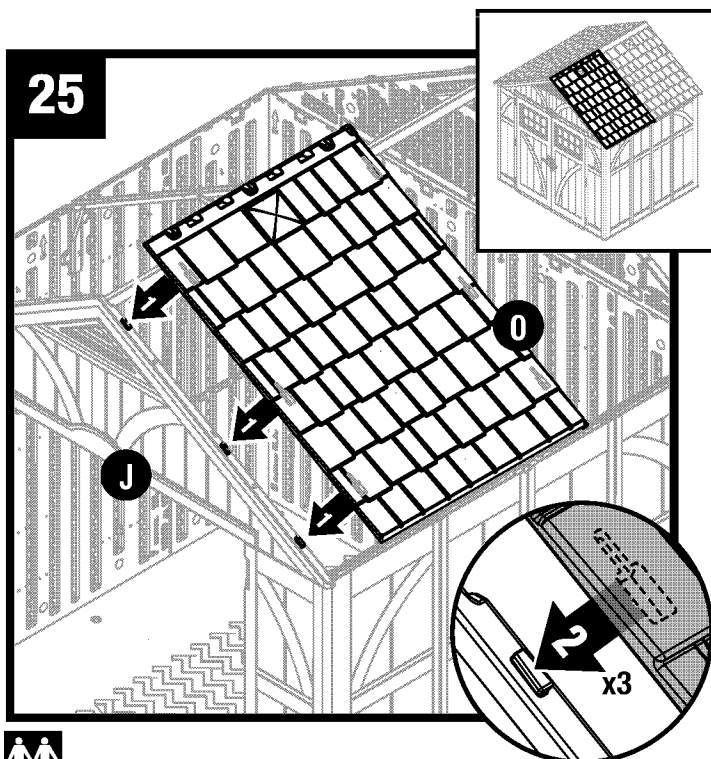

Lay right roof (O) directly over three tabs on right side of front header (J). With right roof slots seated over/on header tabs, check alignment in all three spots.



Slide right roof (O) down towards the outside of shed. You will hear a "snap" when engaged.

Shed Assembly/Roof (continued)

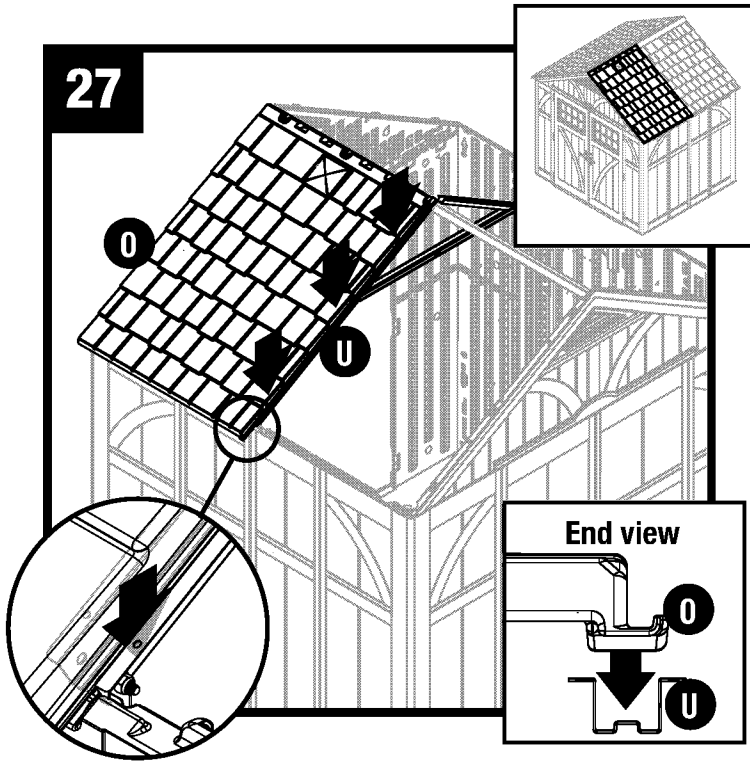

Press edge of right roof (O) into channel on truss leg (U).

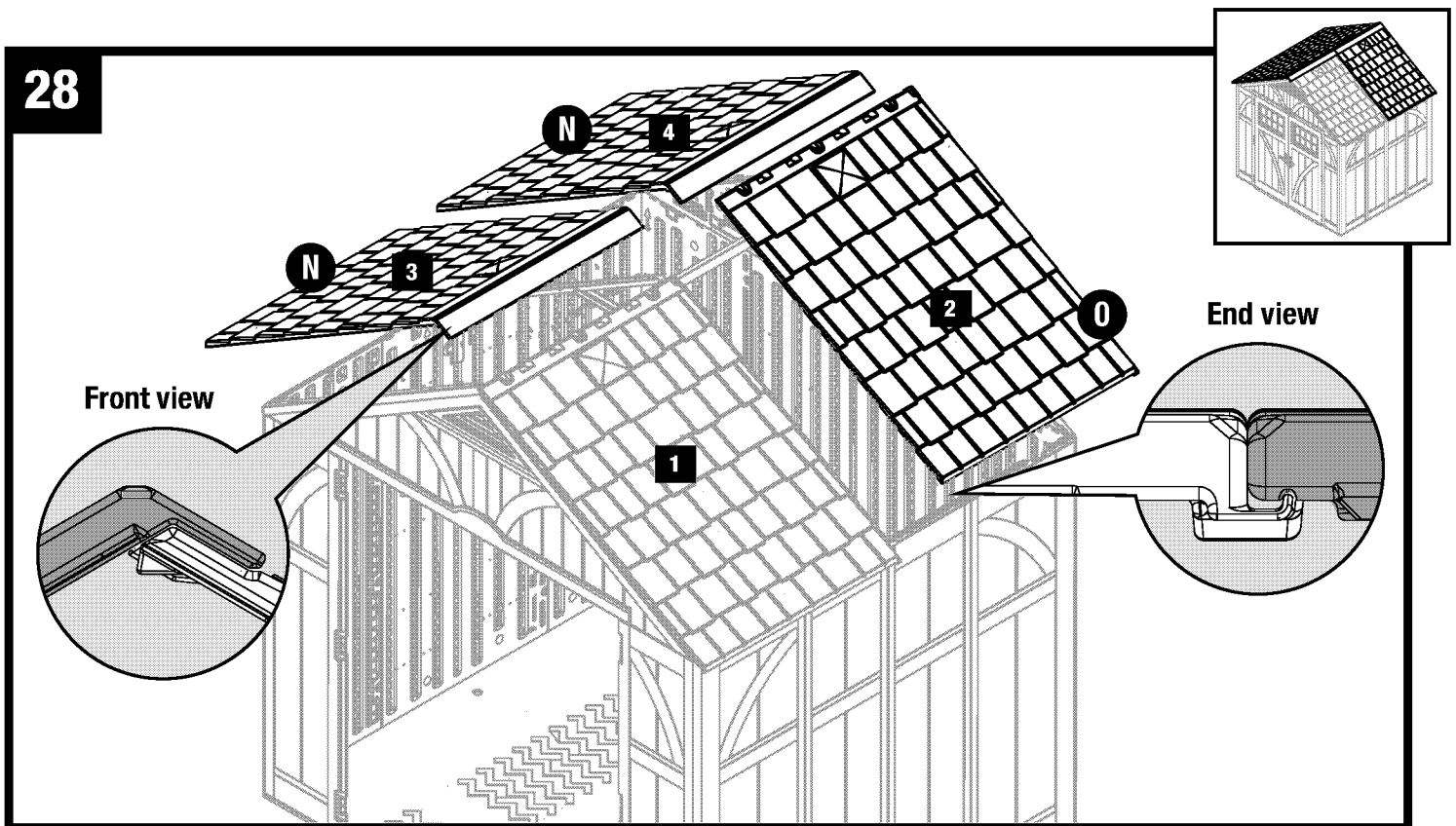

Repeat Steps 25-27 for remaining roof panels. Install panels in the order shown.

Shed Assembly/Roof (continued)

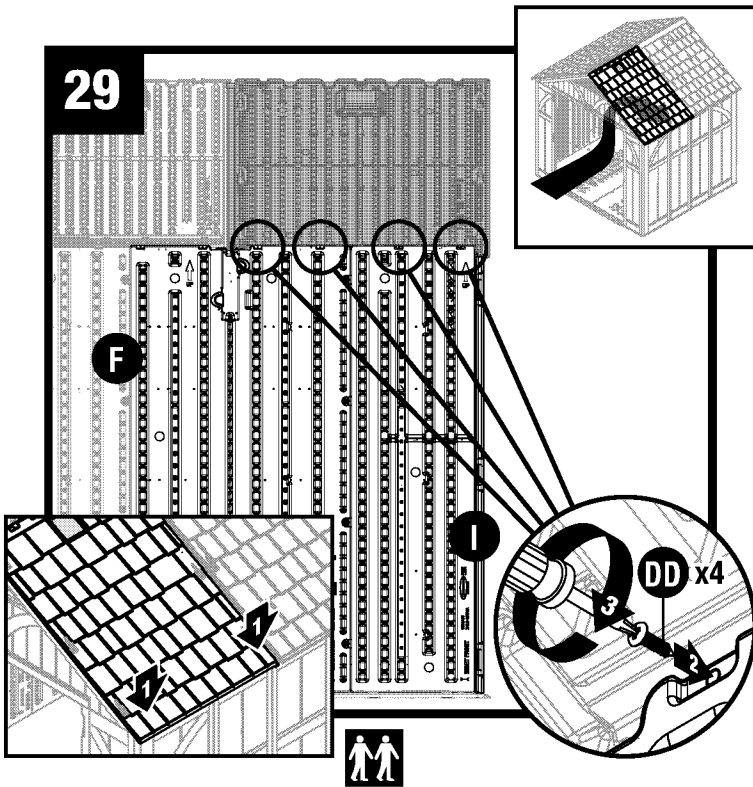

Pull down each lower corner of roof from outside. From inside shed, attach tabs on right front corner (I) and side panel (F) to roof panel with four screws (DD).

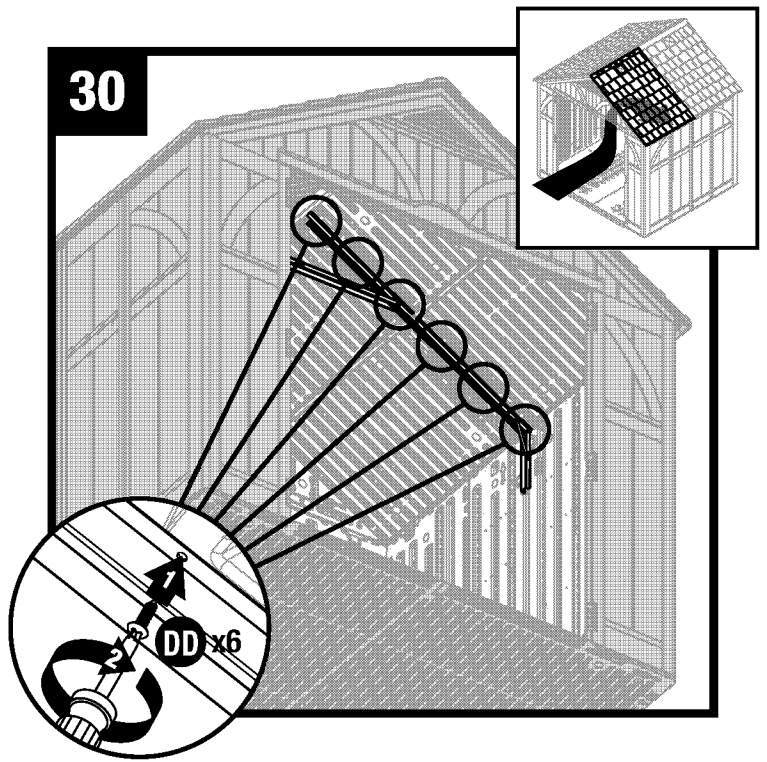

Secure roof to truss using six screws (DD). Each screw will attach at a corresponding screw boss on the roof.

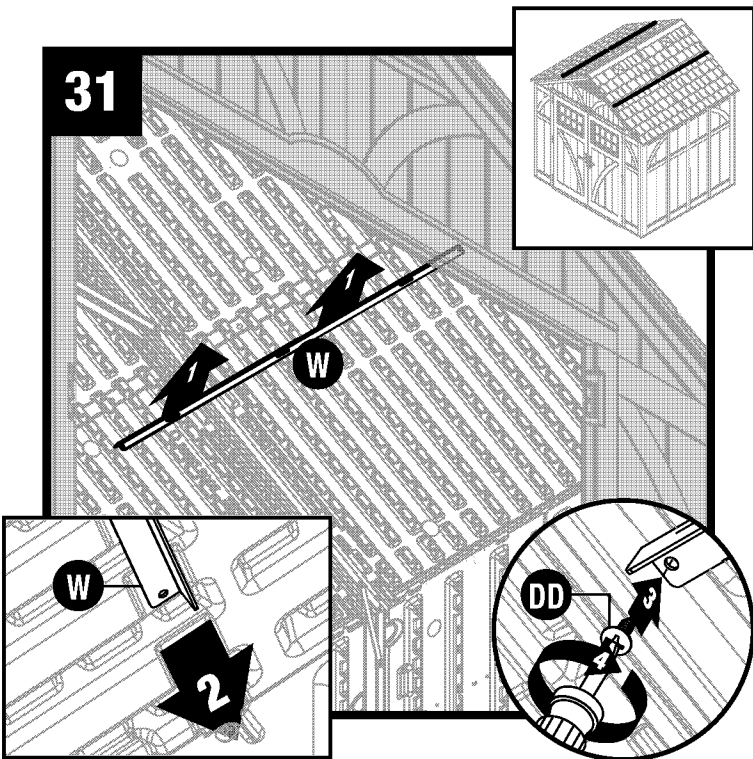

Raise roof support (W) into position against roof. Slide roof support (W) into front header. Secure roof support (W) to underside of truss leg with one screw (DD).

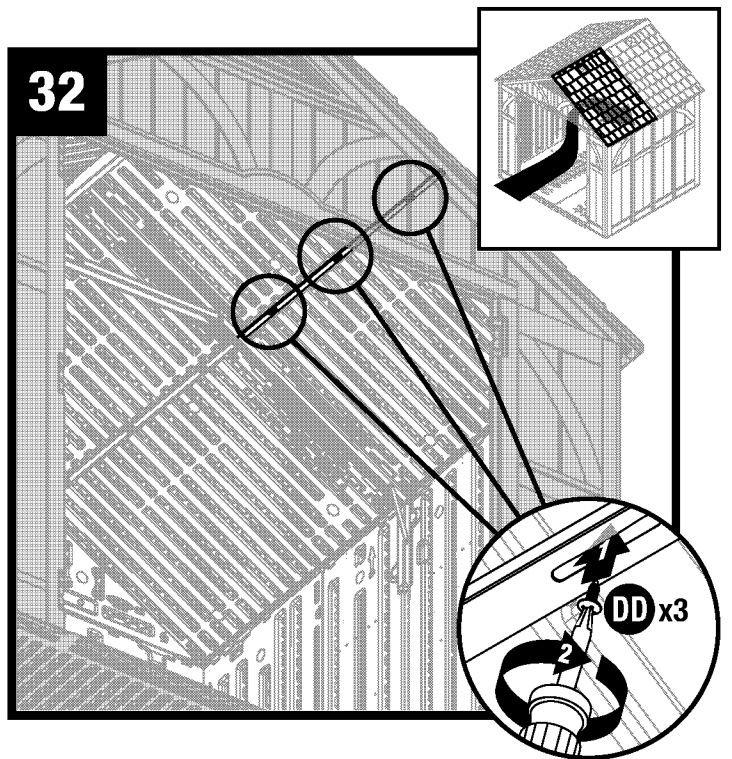

Secure roof support to roof using three screws (DD).

Shed Assembly/Roof (continued)

33

Repeat Steps 29-32 to secure remaining roof panels.

34

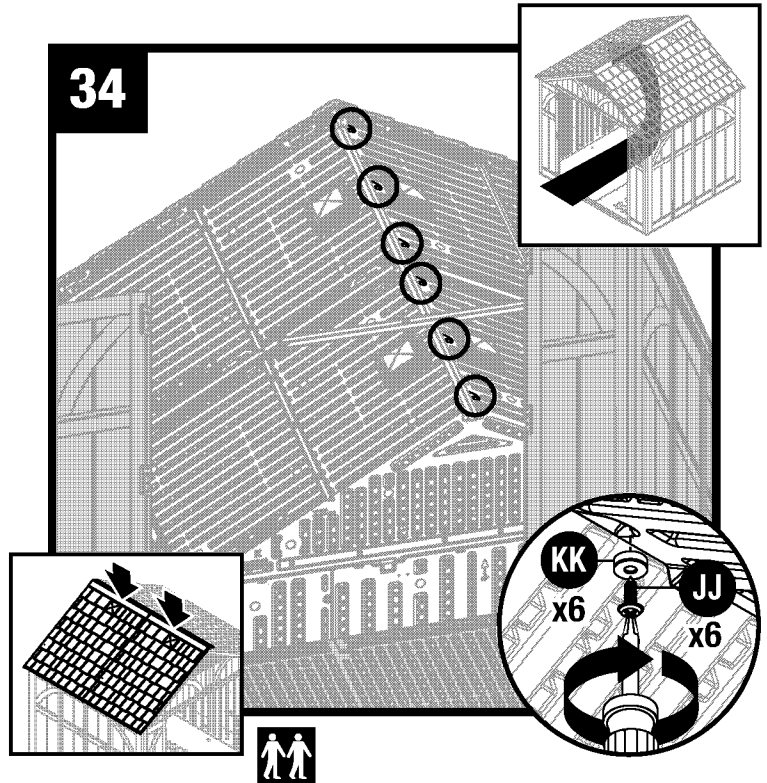

Push down the roof from outside. From inside shed, secure roof panels together along ridge of roof using six rubber washers (KK) and six sealing screws (JJ).

Note: For clarity, illustration is shown with front header removed.

Shed Assembly/Doors

Parts/hardware needed for door assembly are shown on pages 5, 9, and 10.

35

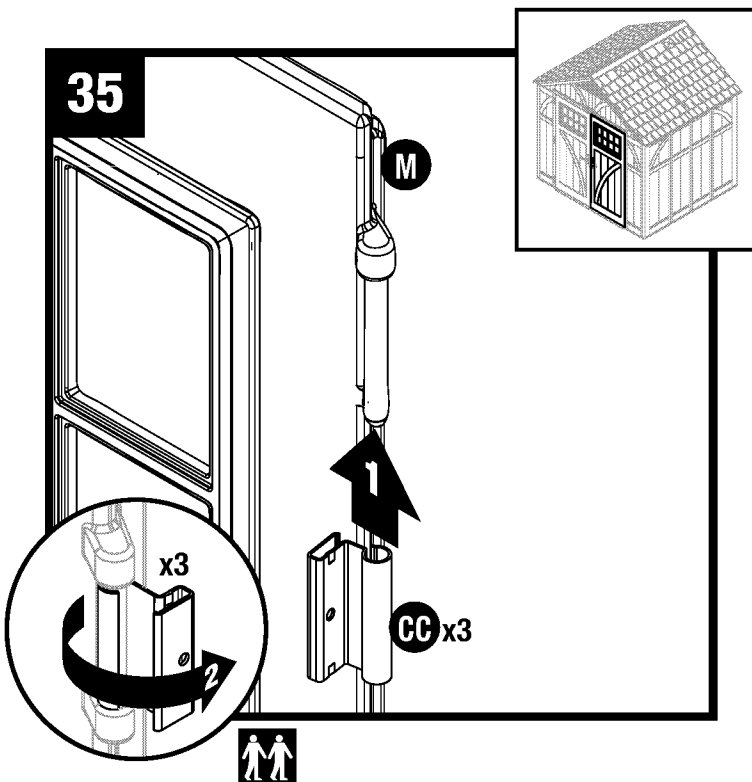

Stand right door (M) upright with three hinge mounts facing right. Slide one metal door hinge (CC) up onto each hinge mount. Rotate door hinges to outside of door.

Shed Assembly/Doors (continued)

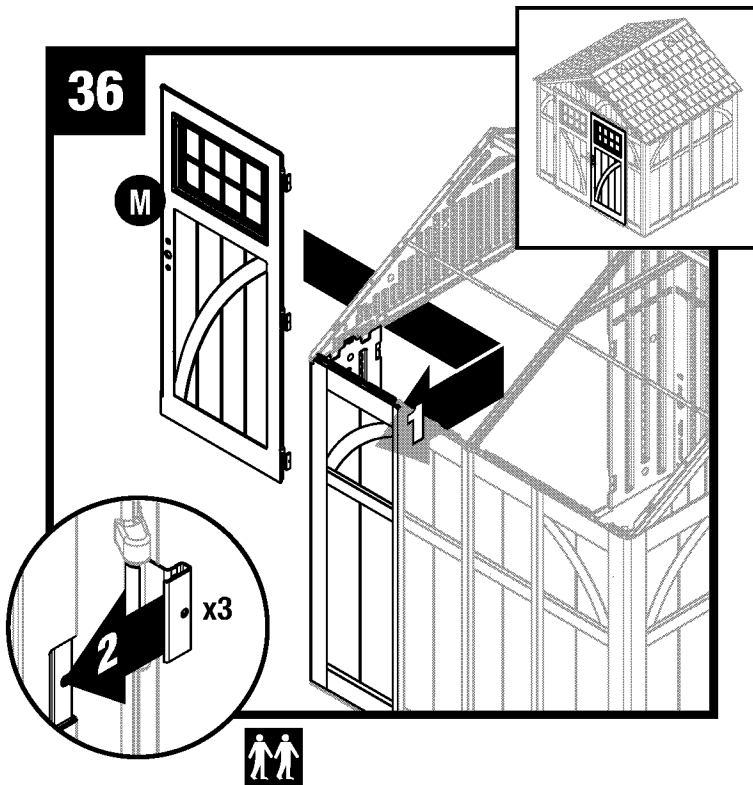

With door hinge in open position, slide one door hinge over each hinge receptacle on inside of right front panel.

Note: For clarity, illustration is shown with roof removed.

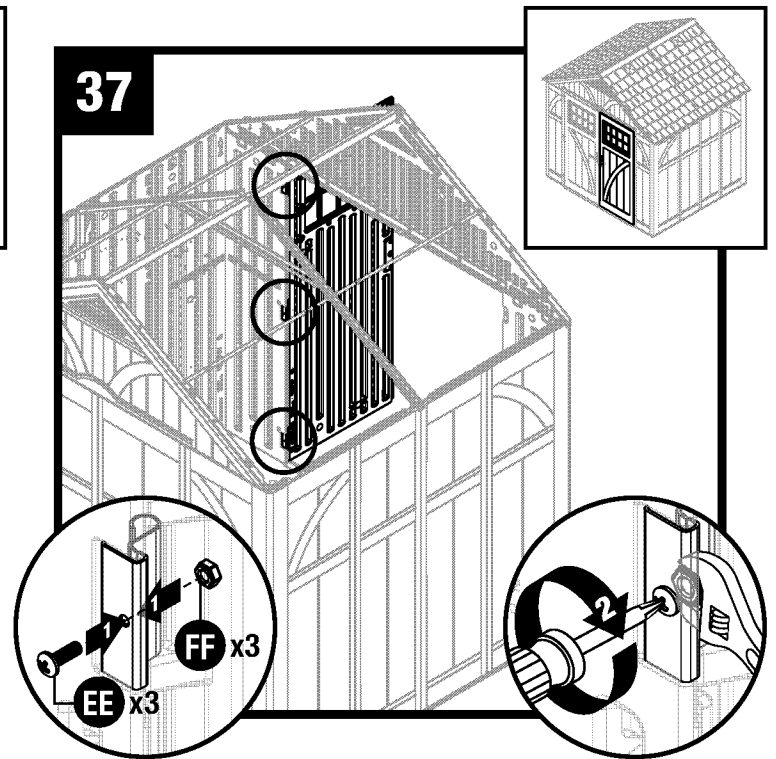

Secure each metal hinge plate with one screw (EE) and one nut (FF).

Repeat Steps 34-36 for left door (L).

Note: For clarity, illustration is shown with roof removed.

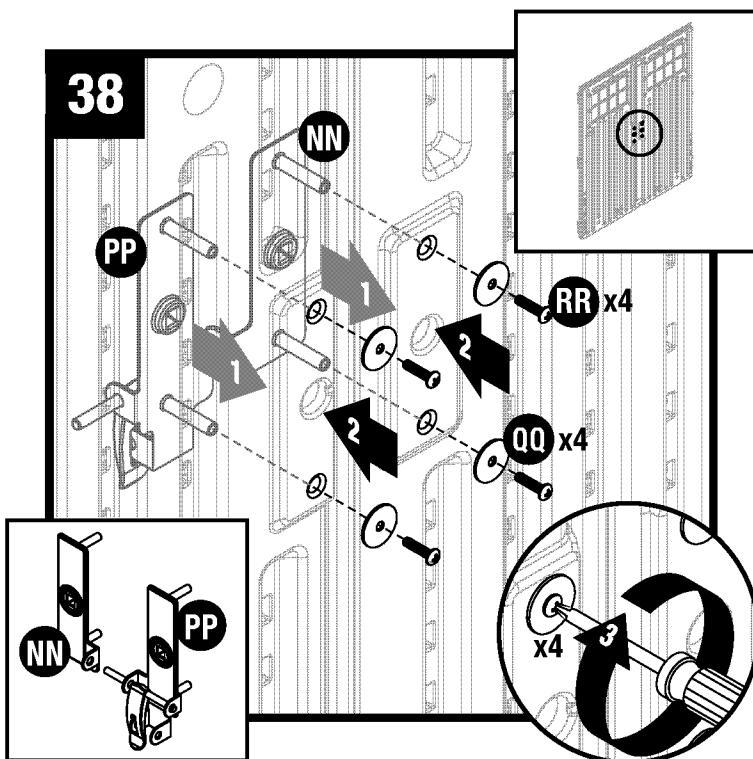

Insert screw stems, on left and right handle plates (NN) and (PP), through the pre-drilled holes in doors. While holding plates in place on exterior of door, secure each with two washers (QQ) and two machine screws (RR).

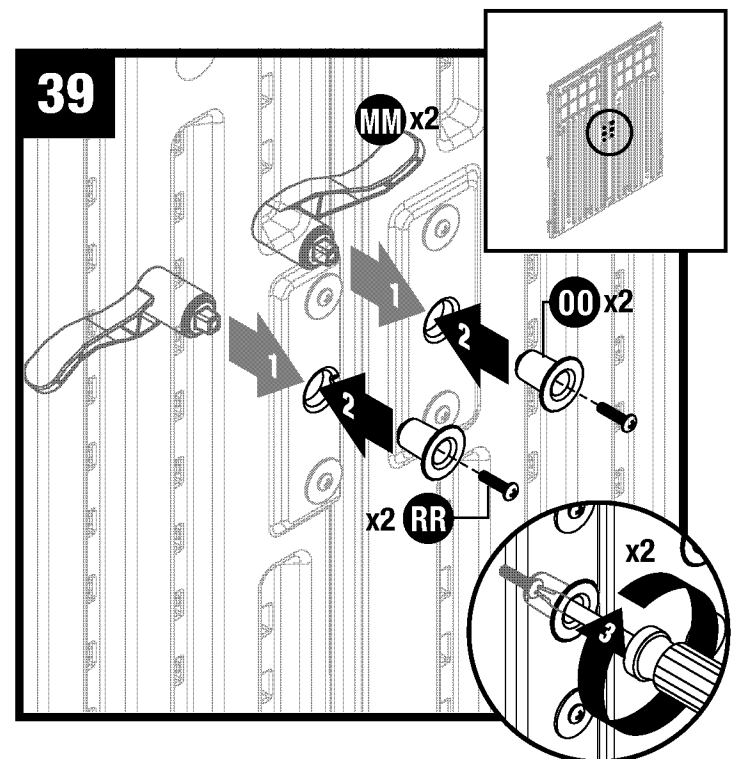

From the outside of doors, insert door handles (MM) through handle plate holes. On inside of doors, place spacers (OO) on each door handle, and secure each with one machine screw (RR).

Shed Assembly/Shelf

Parts/hardware needed for shelf assembly are shown on pages 4 and 9.

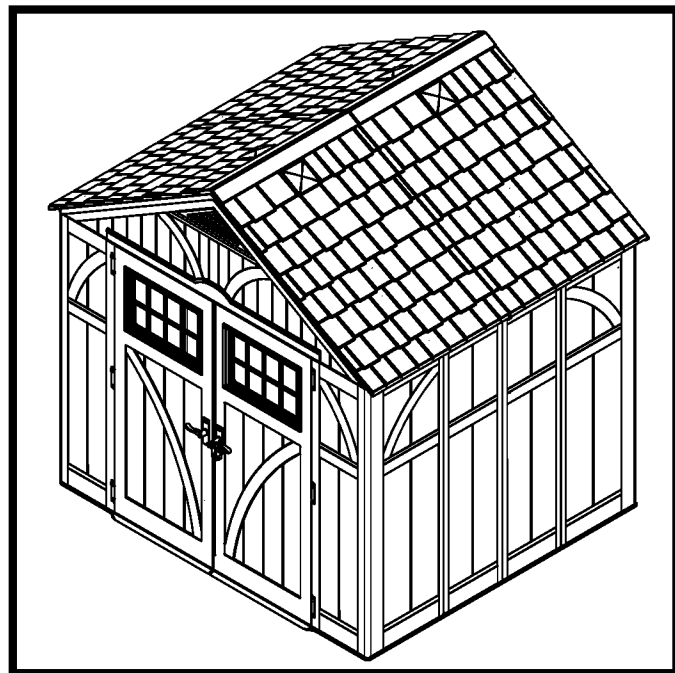
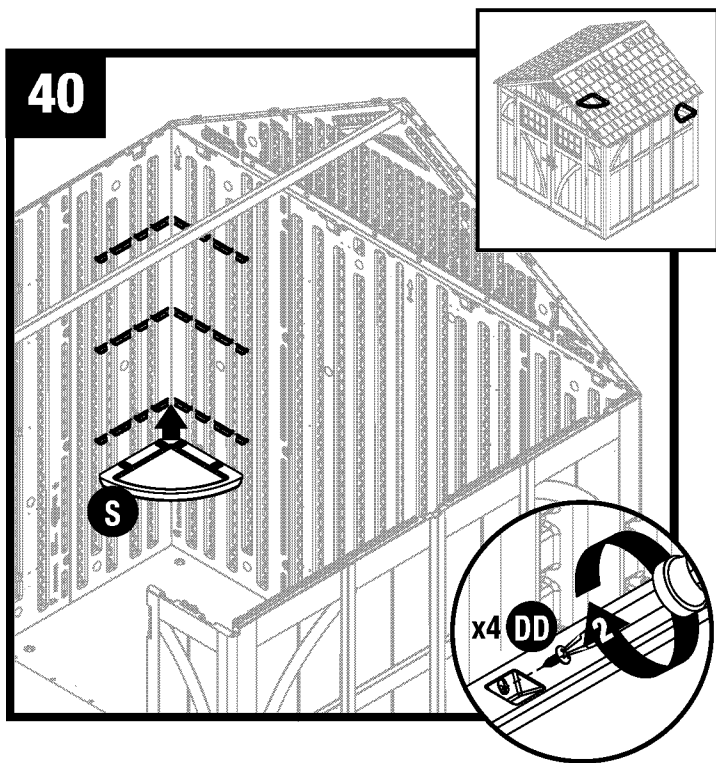

Attach shelf (S) in desired location with four screws (DD)

Repeat for remaining shelf (S).

Note: Shelf can be located in any of the four corners.

Note: For clarity, illustration is shown with roof, front header, and truss removed.

Complete.

Warranty

SUNCAST® Building, Shed and Gazebo Ten Year Limited Warranty

Your SUNCAST® Building, Shed or Gazebo has a TEN YEAR LIMITED WARRANTY against product failure resulting from defects in manufacturing or materials. The warranty period starts on the delivery date. Incidental and consequential damages are not covered.

Warranty Claims

To file a warranty claim contact the manufacturer, SUNCAST® CORPORATION, 701 North Kirk Road, Batavia, Illinois, 60510. Call toll free (800) 846-2345 or visit www.Suncast.com.

SUNCAST® will repair or replace only the parts that failed under the terms of the warranty. In some cases, the replacement parts may not be identical, but they shall be of equal or greater performance than the original part.

We may require proof of purchase. Proof of purchase may be the original dated store receipt. We may require evidence of the failure. Evidence of failure may include photographs or returning failed components to SUNCAST.

Warranty Limitations

THIS WARRANTY COVERS ONLY DEFECTS THAT AFFECT THE FORM, FIT OR FUNCTION OF THE UNIT. It excludes natural aging of the unit, discoloration, ordinary wear and tear, ordinary weathering, sunlight fading, or rust. It excludes staining caused by mold, mildew or tree sap and damage caused by animals including insects, vermin or household pets. The warranty does not cover damage caused by Acts of Nature including but not limited to: wind in excess of 65 mph; tornado; hurricane; microburst; hail; flood; blizzard; extreme heat; pollution or fire events.

The following actions void the warranty: improper assembly; assembly on a foundation other than as described in the assembly instructions; use above intended and reasonable capacity; misuse; abuse; failure to perform ordinary maintenance; failure to remove snow over 8 inches deep; modification; cleaning with abrasive tools, exposing the unit to heat sources and vandalism. Painting, sandblasting, cleaning with harsh chemicals not recommended for plastics voids the warranty on resin components. Modification of the original product voids all warranties. Suncast assumes no liability for any modified product or consequences resulting from failure of a modified product. Damage due to moving, transporting, or relocating the product voids the warranty. Disassembly of this unit for reasons other than authorized repair voids the warranty.

Suncast is not responsible for: loss of use of the unit; labor for repair; inspection fees or disposal costs.

SUNCAST® reserves the right to reimburse the owner the purchase price of the unit on a **STRAIGHT LINE DEPRECIATED BASIS FOR THE LENGTH OF THE WARRANTY IN LIEU OF REPAIR OR REPLACEMENT.** The Purchase Price does not include taxes, delivery charges, site preparation costs, permits, fees, assembly costs, or disposal costs.

THIS WARRANTY IS NONTRANSFERABLE. IT IS VALID FOR NORMAL HOUSEHOLD USE ONLY. THE WARRANTY IS VOIDED BY COMMERCIAL OR INDUSTRIAL USE. IT EXCLUDES FLOOR MODELS, CLEARANCE AND OPEN BOX UNITS.

Notice

Suncast does not represent that this unit will meet city, county, state, homeowner's association standards or zoning requirements. The owner is responsible for securing all permits and meeting other requirements needed for placement, construction and use.

THE MANUFACTURER'S LIABILITY HEREUNDER IS LIMITED SOLELY TO THE REPAIR OR REPLACEMENT OF THE DEFECTIVE PRODUCT OR PART AND THE MANUFACTURER SHALL IN NO EVENT BE LIABLE FOR ANY INCIDENTAL OR CONSEQUENTIAL DAMAGES WHICH MAY RESULT FROM ANY DEFECT IN MATERIAL OR WORKMANSHIP OR FROM THE BREACH OF ANY EXPRESS OR IMPLIED WARRANTY.

This warranty gives you specific legal rights, and you may also have other rights which vary from state to state. Some states do not allow the exclusion or limitation of incidental or consequential damages; the limitation or exclusion may not apply to you.